

Structural Biology from SFX SPB

James H Naismith
On behalf of wider SFX/SPB
Consortium

3-16 keV
in vacuum

Refocusing CRLs

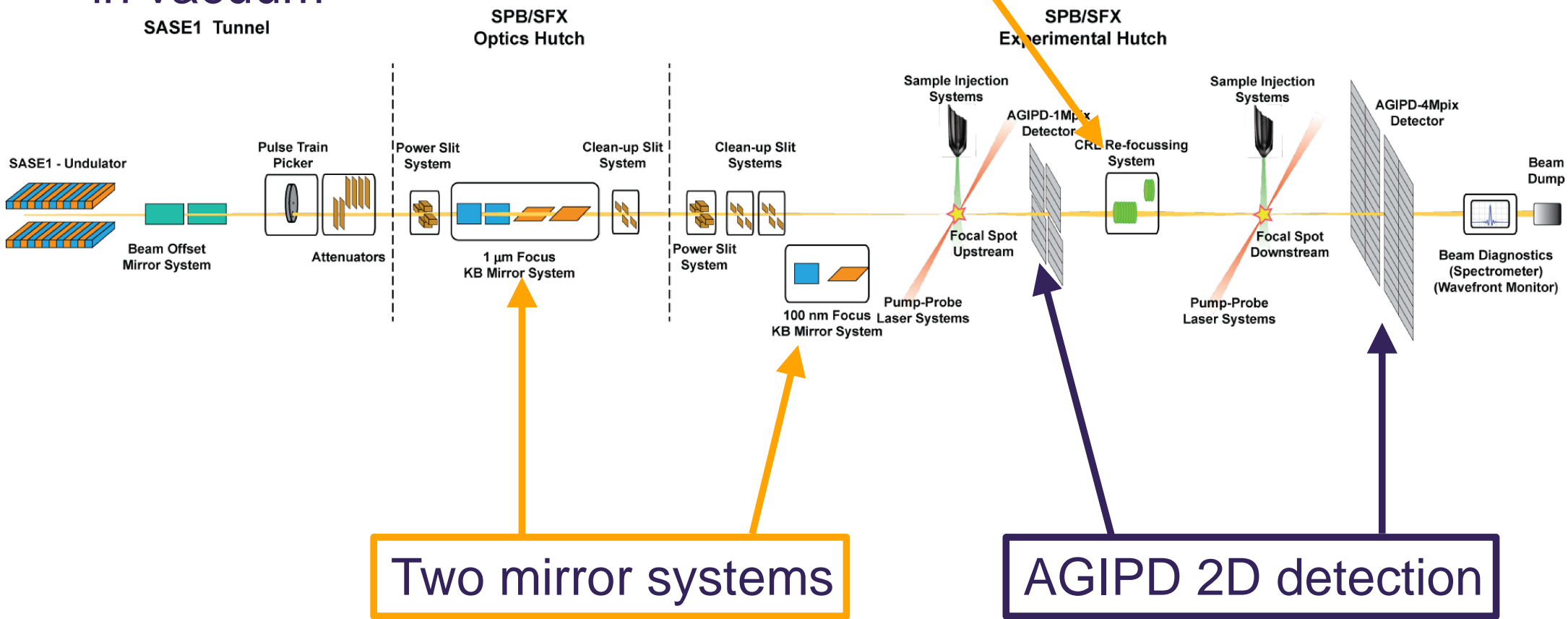

Focal spot improvement

Marked improvement in focal properties following the successful installation and first commissioning of the micron-scale focusing mirrors

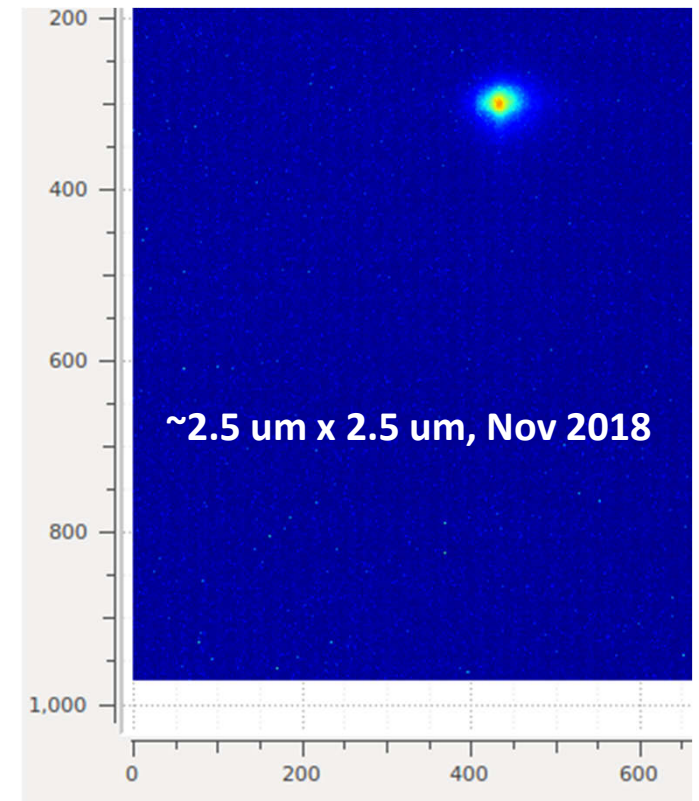
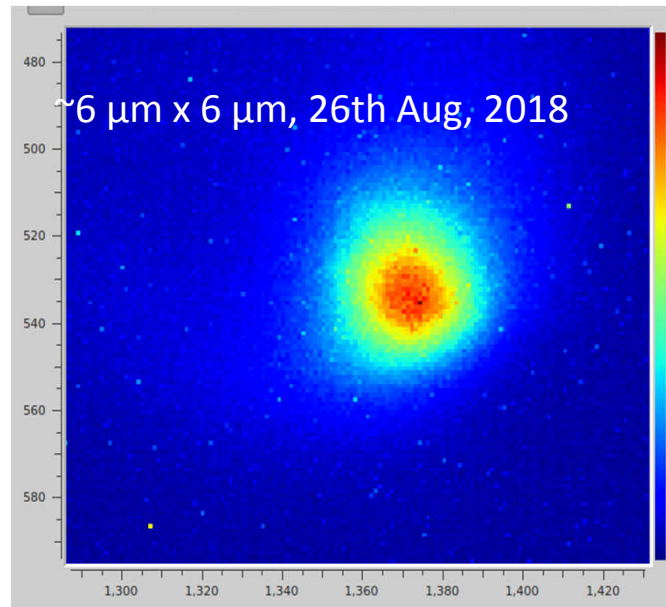
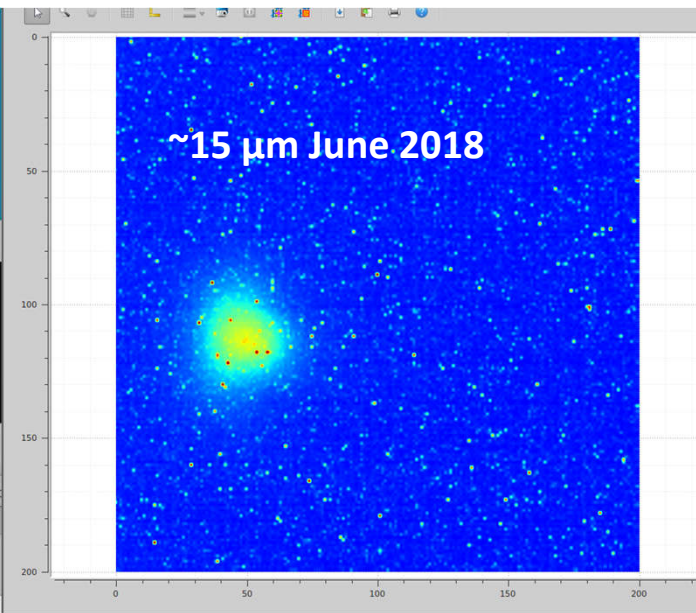

Focal spot is expected to improve with more commissioning

Highlights from SFX SPB

- Two (user) papers published in Nature Communications
 - Two more accepted for publication (Optics Letters, Scientific Data)
 - One more submitted
 - At least three more in draft (probably more)
- Papers in draft from the other types of experiments too
 - Still expecting ~1 papers per proposal from experiments done so far
- Demonstration that MHz serial crystallography can be realised—hence the European XFEL is open for business for structural biology
- Up to 1760 pulses per second now in progress. Already had 5000 pulses per second in hutch.
 - many challenges with parallel operation at SES3 may limit this (severely)
 - AGIPD provides excellent quality data for serial crystallography (despite some challenges)
- Pump-probe and mixing experiments performed too
- Improved focal spot size

ARTICLE

DOI: 10.1038/s41467-018-05953-4 OPEN

Megahertz data collection from protein microcrystals at an X-ray free-electron laser

Marie Luise Grünbein¹, Johan Bielecki², Alexander Gorel¹, Miriam Stricker¹, Richard Bean², Marco Cammarata³, Katerina Dörner², Lars Fröhlich⁴, Elisabeth Hartmann¹, Steffen Hauf², Mario Hilpert¹, Yoonhee Kim², Marco Kloos¹, Romain Letrun², Marc Messerschmidt^{2,5}, Grant Mills^{2,6}, Gabriela Nass Kovacs¹, Marco Ramilli², Christopher M. Roome¹, Tokushi Sato^{2,7}, Matthias Scholz⁴, Michel Sliwa⁸, Jolanta Sztuk-Dambietz², Martin Weik⁹, Britta Weinhausen², Nasser Al-Qudami², Djelloul Boukhelef², Sandor Brockhauser^{2,10}, Wajid Ehsan², Moritz Emons², Sergey Esenov², Hans Fangohr², Alexander Kaukher², Thomas Kluyver², Max Lederer², Luis Maia², Maurizio Manetti², Thomas Michelat², Astrid Münnich², Florent Pallas², Guido Palmer², Gianpietro Previtali², Natascha Raab², Alessandro Silenzi², Janusz Szuba², Sandhya Venkatesan², Krzysztof Wrona², Jun Zhu², R. Bruce Doak¹, Robert L. Shoeman¹, Lutz Foucar¹, Jacques-Philippe Colletier⁹, Adrian P. Mancuso², Thomas R.M. Barends¹, Claudiu A. Stan¹¹ & Ilme Schlichting¹

X-ray free-electron lasers (XFELs) enable novel experiments because of their high peak

ARTICLE

DOI: 10.1038/s41467-018-06156-7 OPEN

Megahertz serial crystallography

Max O. Wiedorn¹ et al.[#]

The new European X-ray free electron laser is the first X-ray free-electron laser capable of delivering X-ray pulses with a megahertz inter-pulse spacing, more than four orders of magnitude higher than previously possible. However, to date, it has been unclear whether it would indeed be possible to measure high-quality structures at megahertz pulse repetition rates. Here, we show that high-quality structures can indeed be obtained using currently available operating conditions at the European XFEL. We present two complete data sets, one from the well-known model system lysozyme and the other from a so far unknown complex of a β -lactamase from *K. pneumoniae* involved in antibiotic resistance. This result opens up megahertz SFX as a tool for reliable structure determination, substrate screening and the efficient measurement of the evolution and dynamics of molecular structures using megahertz repetition rate pulses available at this new class of X-ray laser source.

First user papers from the European SFX SPB

- Two more accepted:
- Grünbein, et al Scientific Data, accepted
- H. Kirkwood, Optics Letters, accepted
- More submitted and in progress

Jets and detector working at MHz

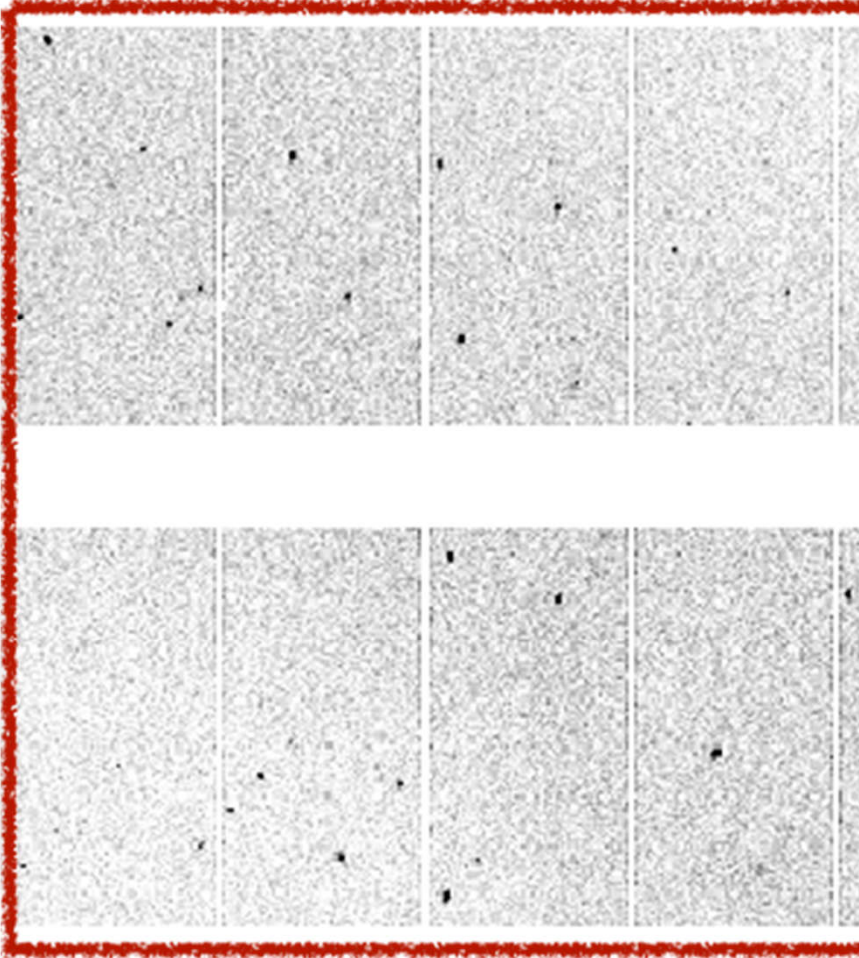
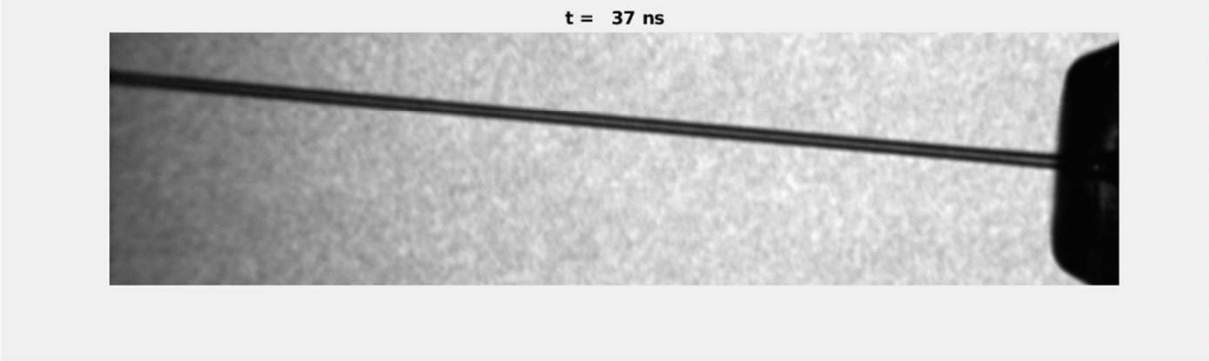
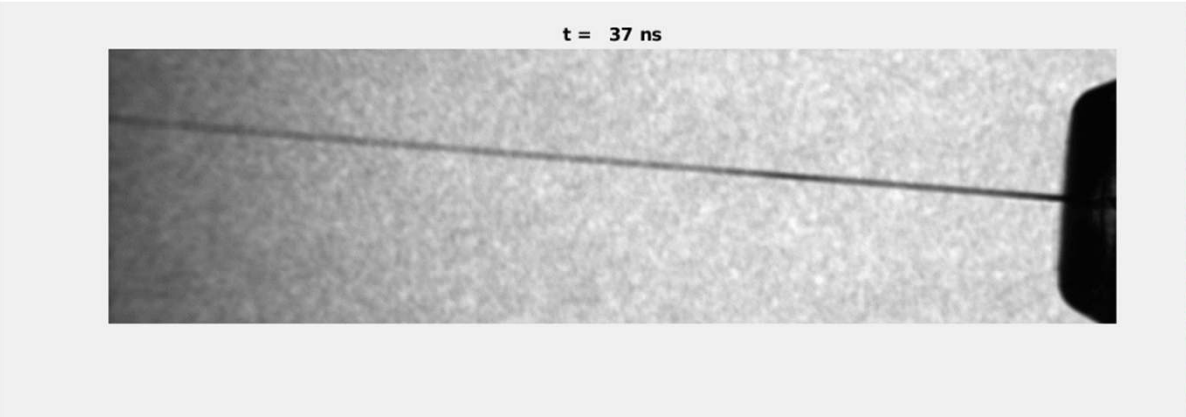

Detector 1M AGIP

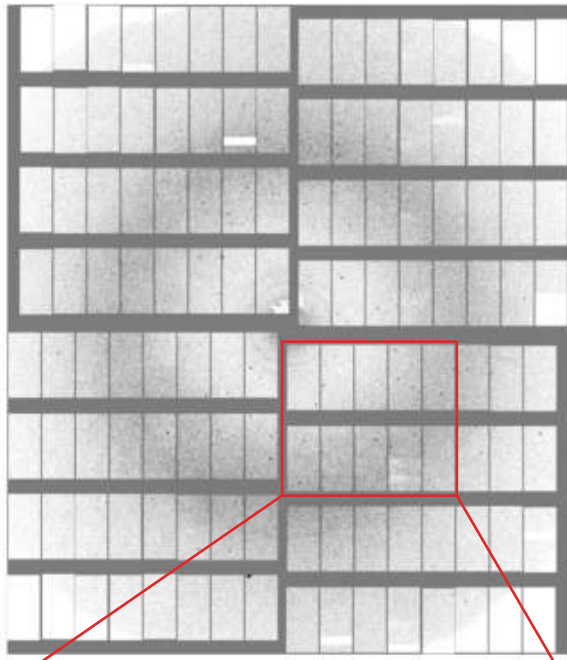

Megahertz data collection from protein microcrystals at an X-ray free-electron laser [Marie Luise Grünbein](#), *Nature Communications* **volume 9**, Article number: 3487 (2018)

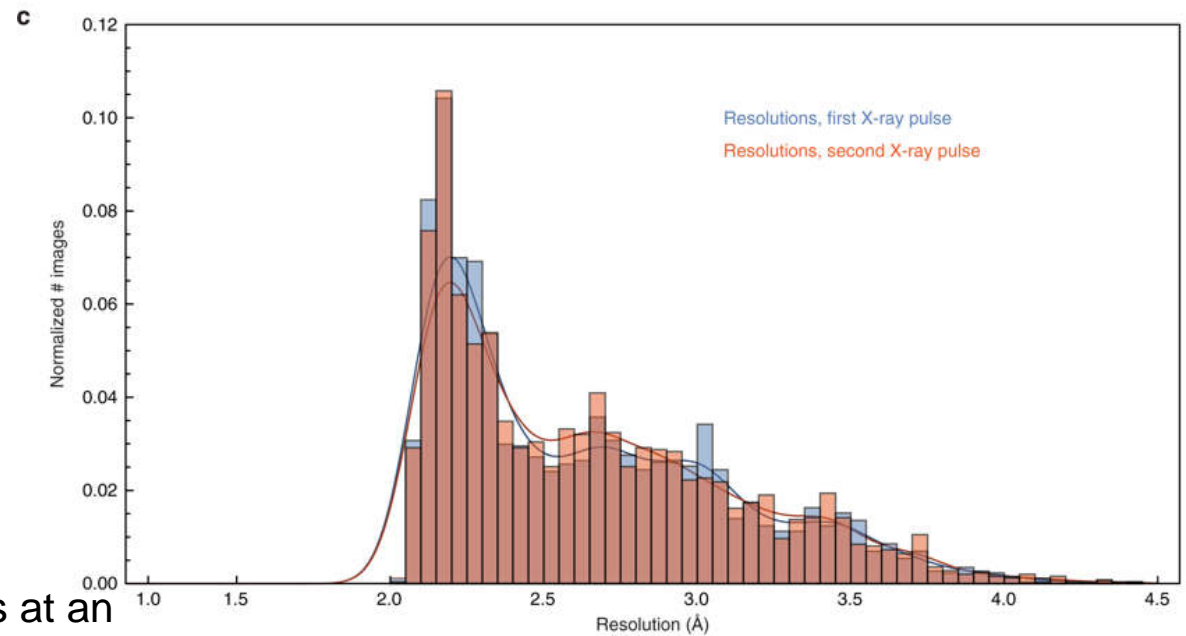
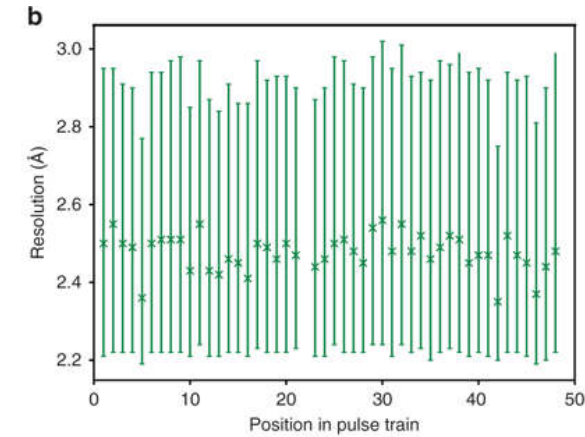
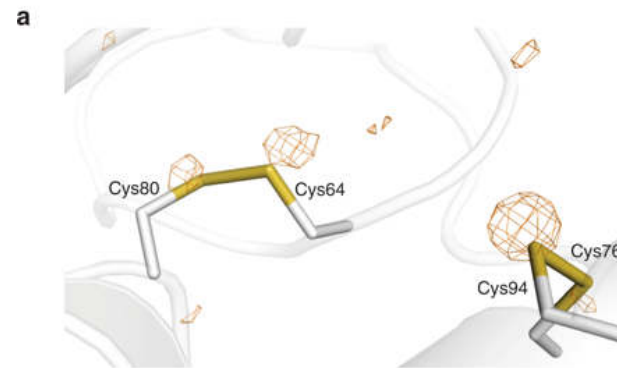

Parameter	Lysozyme	CTX-M-14
Photon energy (mean value)	9300 eV	9150 eV
X-ray focus	15 μm (FWHM)	15 μm (FWHM)
Pulse energy at sample (assuming 50% beamline transmission)	290 μJ	526 μJ
Pulse length	50 fs	50 fs
No. of hits/indexed lattices	25,193/25,531	14,445/12,474
No. of unique reflections	12,387 (1171)	27,838 (2715)
Resolution range	21.99–1.76 (1.82–1.76) \AA	34.6–1.69 (1.75–1.69) \AA
Completeness	99.64% (97.25%)	99.89% (99.45%)
R_{split}	0.106 (0.446)	0.197 (0.476)
$I/\sigma(I)$	7.36 (2.62)	4.37 (2.30)
$CC_{1/2}$	0.98 (0.79)	0.93 (0.63)
CC^*	0.99 (0.94)	0.98 (0.88)
Wilson B -factor	26.18 \AA^2	26.80 \AA^2
R_{Work}	0.157 (0.211)	0.176 (0.27)
R_{Free}	0.173 (0.218)	0.21 ((0.30)
Rmsd bonds/Rmsd angles	0.010 \AA /0.994 $^\circ$	0.008 \AA /1.22 $^\circ$

Megahertz serial crystallography [Max O. Wiedorn](#),
Nature Communications **volume 9**, Article number: 4025 (2018)

Current sample injector

- ASU model in regular use
- Doak, Schulz et al have designed a new upgraded nozzle

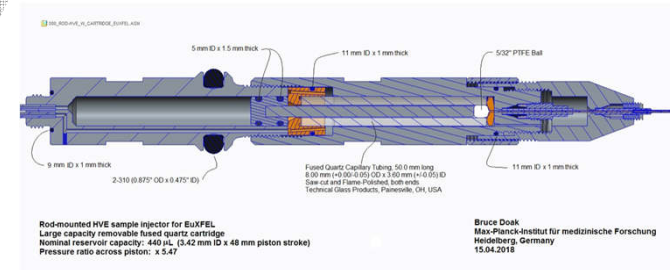

A versatile liquid-jet setup for the European XFEL

J. Schulz, J. Bielecki, R. B. Doak, K. Dörner, R. Graceffa, R. L. Shoeman, M. Sikorski, P. Thute, D. Westphal and A. P. Mancuso

J. Synchrotron Rad. (2019), **26**, 339–345

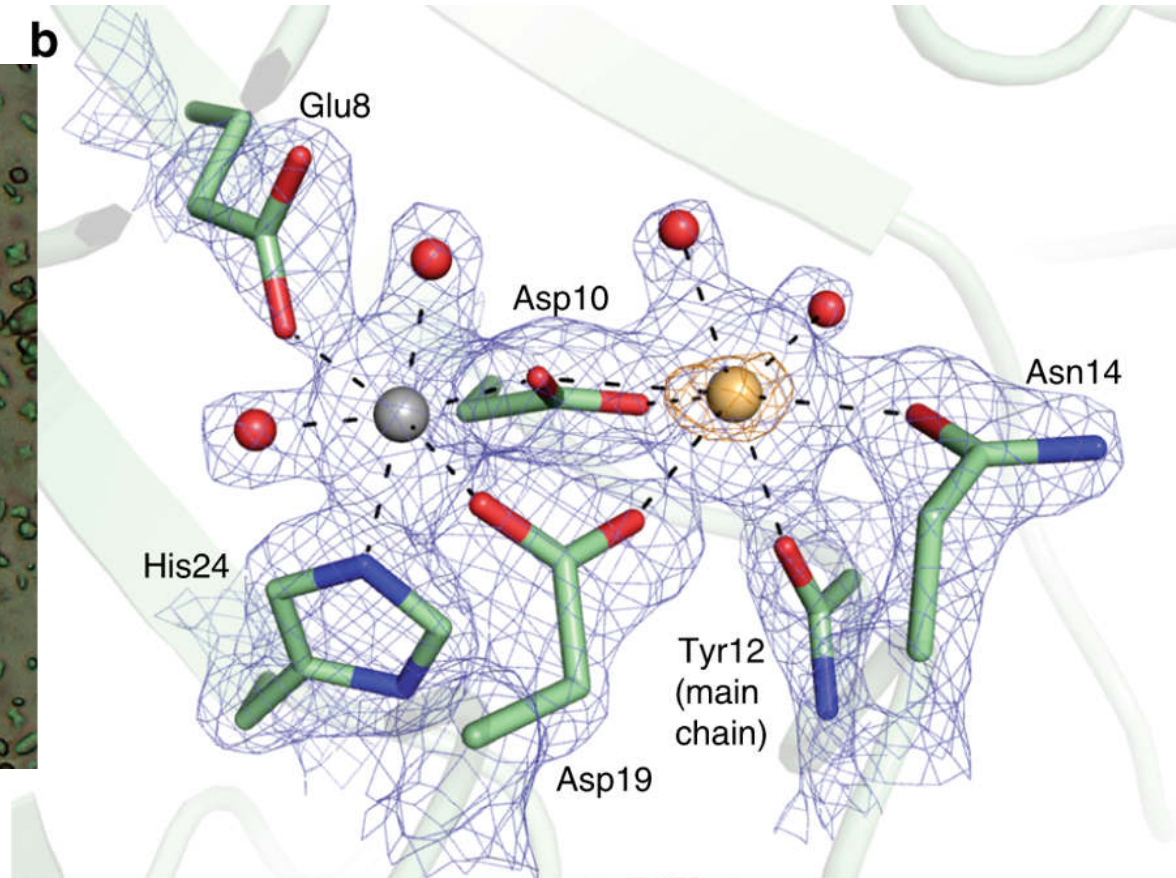
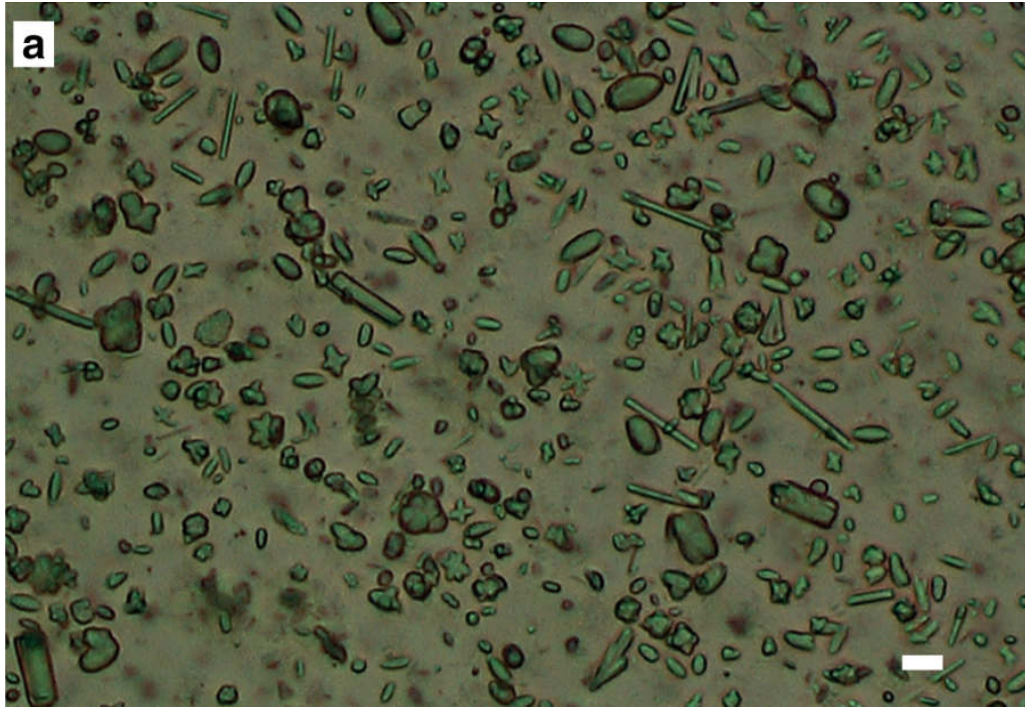

Megahertz data collection from protein microcrystals at an X-ray free-electron laser [Marie Luise Grünbein](#), *Nature Communications* **volume 9**, Article number: 3487 (2018)

Status of the instrumentation

	Status first experiments	Run 2 status	Present status	Run 4 expected status
Focal spot size	~15-20 μm CRL focus	~5-7 μm mirror focus	~3 μm or better if lucky	\lesssim 3 μm and few hundred nm
Number of pulses per train/ per second usable	15 / 150	120 / 1200	176 / 1760	176 / 1760 to 352 / 3520 (detector firmware dependent)
Optical pump laser	Yes	Yes	Yes	Yes. Timing tool available.
Suitability for single particle imaging experiments	Okay for first experiments	Better than expected	Expected to be "yes" — experiments in May	Expected to be "yes" — experiments in May
Status of the controls	Minimal functionality, poor reliability	Better reliability, still minimal functionality	Better reliability, still very limited functionality (first scan tool tests recently)	Hopefully better.

Pump-probe timing jitter measurements at SPB/SFX

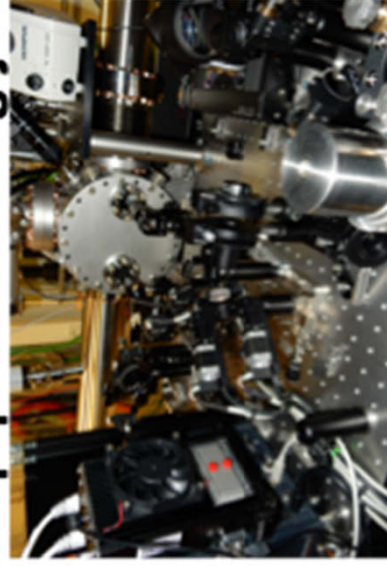

Photon arrival monitor (PAM) was successfully installed and commissioned

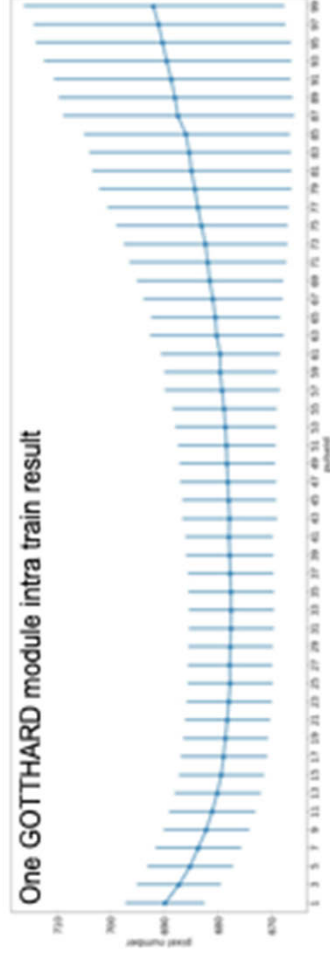
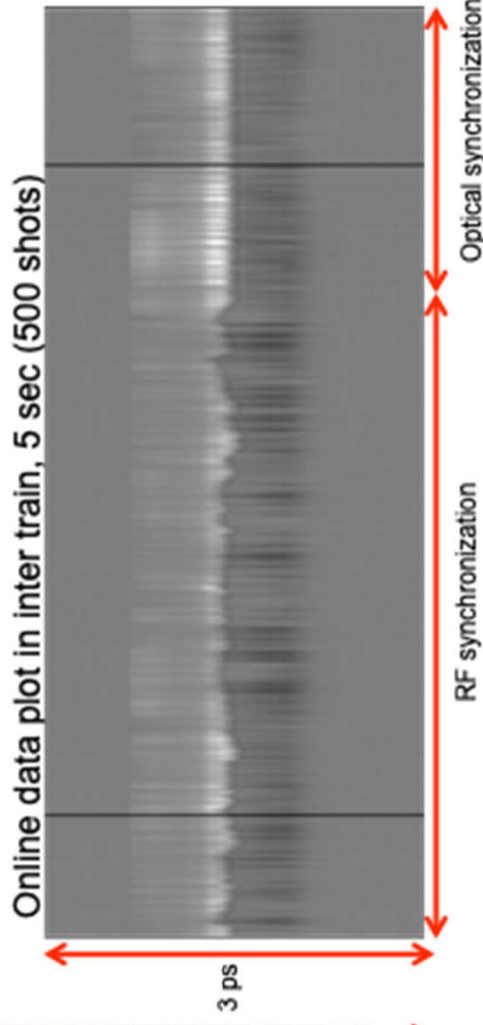

**Less than 100 fs (FWHM) jitter
at 1.1 MHz intra train and 10 Hz inter train with optical synchronization.
No significant timing drift over 12 hours.
Detailed analysis is on going**

Capabilities for next run

- Serial crystallography
 - including pump-probe, mixing jets and more
- Single particle imaging
 - Easier for larger particles, but perhaps possible down to samples 100 nm in size
- Timing tool for ultrafast experiments
- Perhaps TR-SAXS (first SAXS experiment was quite challenging)

- And more (see detailed feasibility studies for more info)

- AGIPD with 176 frames per train capable (full 352 not yet achieved due to firmware limitations)

Planned developments

- SFX project in air/Helium part in track for commissioning with beam in April
 - Includes Jungfrau detector (initially 1.5 Mpx, later 4 Mpx)
 - Uses Roadrunner III (in air) for delivery of fixed targets (chips) or liquid jets
 - User operation from first part of 2020 planned
- SFX in vacuum to be delivered later
 - Initially planned for end 2019 / start 2020 — depends on a variety of deliverables from outside SPB/SFX group
 - Will support liquid jet and fixed target samples with AGIPD 4 Mpx detector

Downstream more ambitious

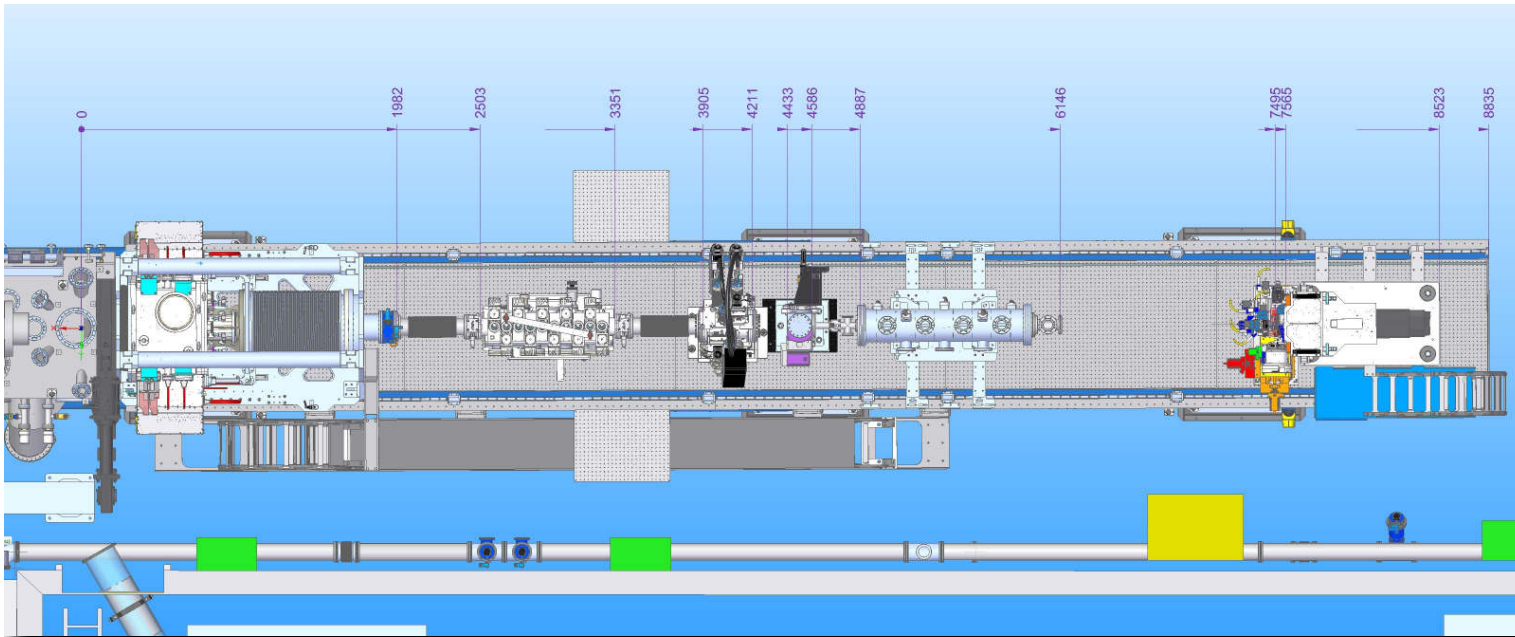

Sample delivery
Detector
Dedicated for MX only

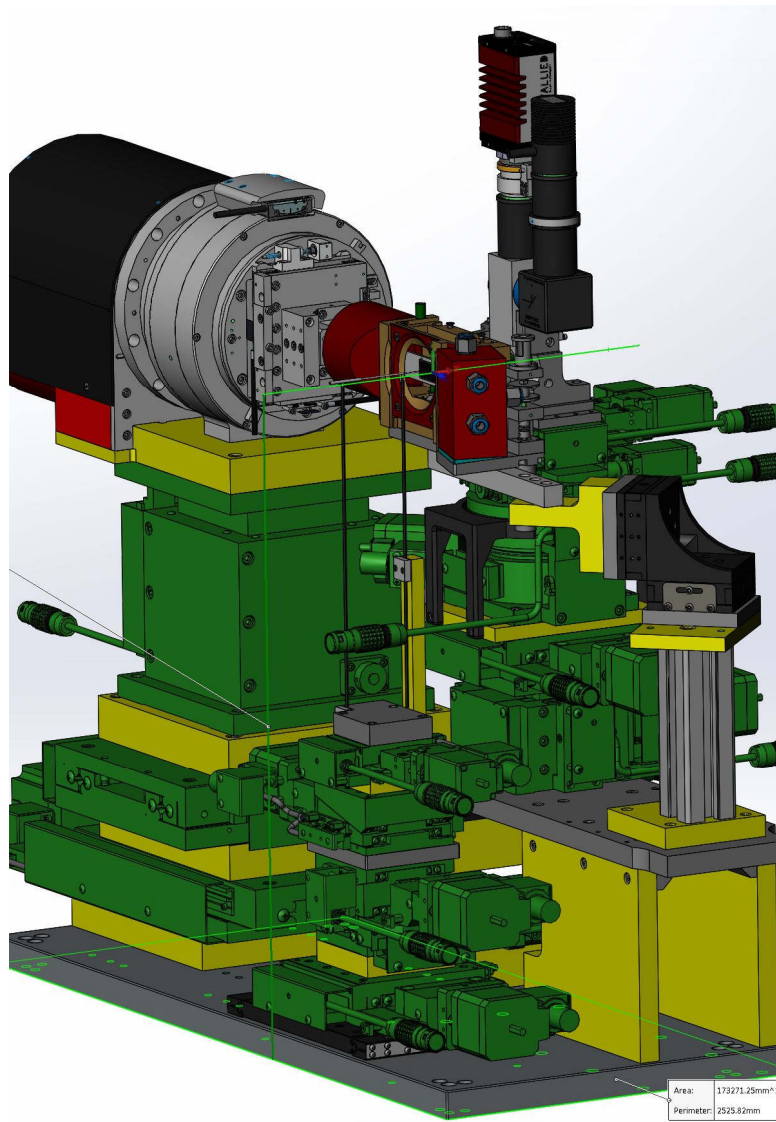

Road runner for SFX

Jungfrau April
target

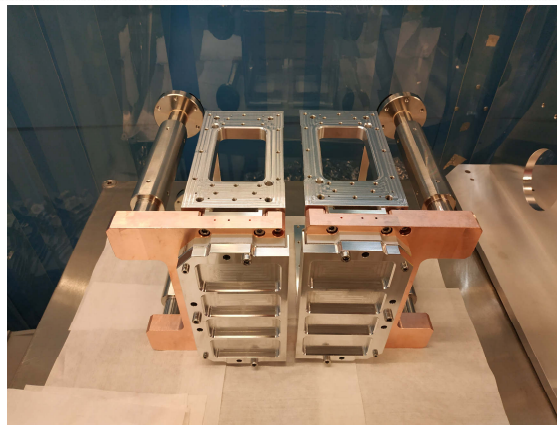
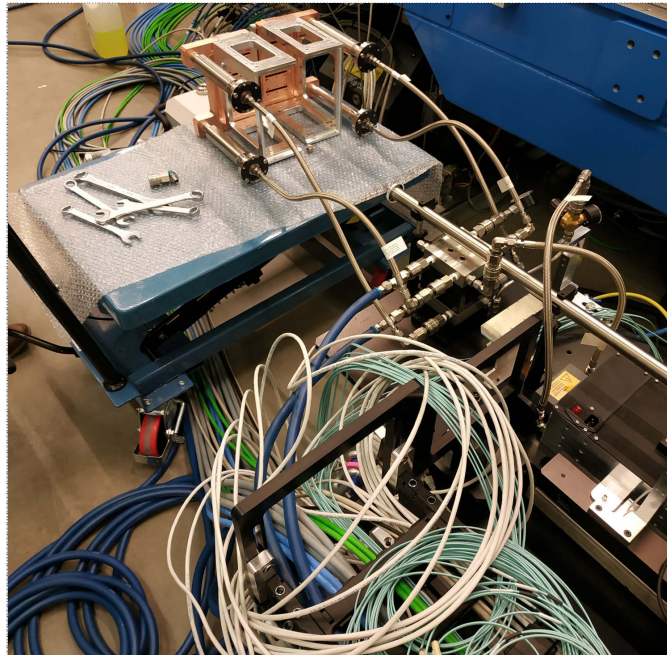

Conclusions

- Successful experiments at SPB/SFX and shown that the MHz rate can be exploited.
- Currently plan 176 pulses per train (1760 per second), fastest in world
- The SFX in air/Helium setup utilising Roadrunner and Jungfrau for commissioning with beam in April this year. Users from 2020.
- SFX in vacuum further away, the AGIPD 4 Mpx detector will be the centrepiece of this interaction region.

Acknowledgments: SPB/SFX instrument

Richard Bean

Johan Bielecki

Thomas Dietze

Katerina Doerner (Sample env)

Carsten Fortmann-Grote
(EUCALL project)

Klaus Giewekemeyer

Rita Graceffa (Sample env)

Henry Kirkwood

Yoonhee Kim

Alexis Legrand

Romain Letrun

Grant Mills

Luis Lopez Morillo

Bradley Manning

Marc Messerschmidt (now ASU)

Nadja Reimers

Adam Round

Tokushi Sato

Cedric Signe-Takem

Marcin Sikorski

Andrew Stawniczy

Stephan Stern

Prasad Thute

(Sample env)

Britta Weinhausen (now Bruker)

Patrik Vagovic



Many thanks to the **SFX Executive Board** for very constructive collaboration and support. Particular thanks to **all European XFEL groups supporting** (too many to mention), the AGIPD consortium, the accelerator team and many more.

Acknowledgements: Funding



Australian Government
Australian Research Council



**Ministry of Education,
 Science, Research and Sport
 of the Slovak Republic**

PAUL SCHERRER INSTITUT



welcometrust



Universität Hamburg
 DER FORSCHUNG | DER LEHRE | DER BILDUNG



**RESEARCH
 COUNCILS UK**



Vetenskapsrådet



**Bundesministerium
 für Bildung
 und Forschung**



MAX-PLANCK-GESELLSCHAFT



My thoughts for the future?

- XFEL cannot be expensive way to do what we do now
- Its true application will be in the time domain, tomography and single particle will be the major structural tools
- The problem is this will need synchronized pump probe compatible reactions
- There are a number of electron processes in proteins that are very amenable to this
- However this is a subset and this gold rush will deplete such ready to publish systems

XFEL needs to focus on sample preparation and delivery

- Conventional chemical approaches focus on ligand, one off and intensive
- Not enough good experiments in the future without some new technology
- Is mixing the answer?

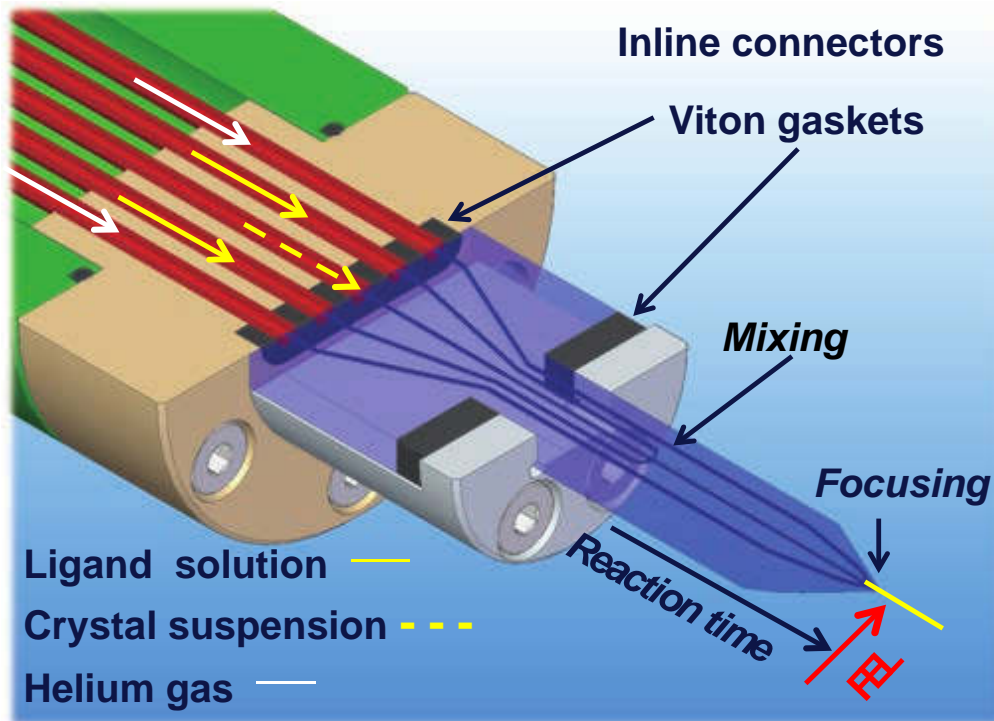

| % # * # \$ @ %
 6) ') * ; %
) * # + - 8 \$

E 2L % 0Q A4P.

D#E85F\$%. E\$\$#'% 9d1 c;	&+ -\$a%+75E\$8# 5F% U2ET7 9l 1 ;	-)FP#3%4 #%E\$a# 9l 7;
CWV%CVW%	ZW%	X'e% _'e%
XWV%VWV%	ZW	ZeW% 7] C%
XWV%VWV%	e	f W% ZWV
eV%V%	Z	^% \ e%
ZV%ZV%	X	X% f
5F5E'%FI %E5#%E\$a#%J%W% eWd'g -\$		

B8\$* # (98) ') * ; % p # + 8\$%8\$%\$.W.23

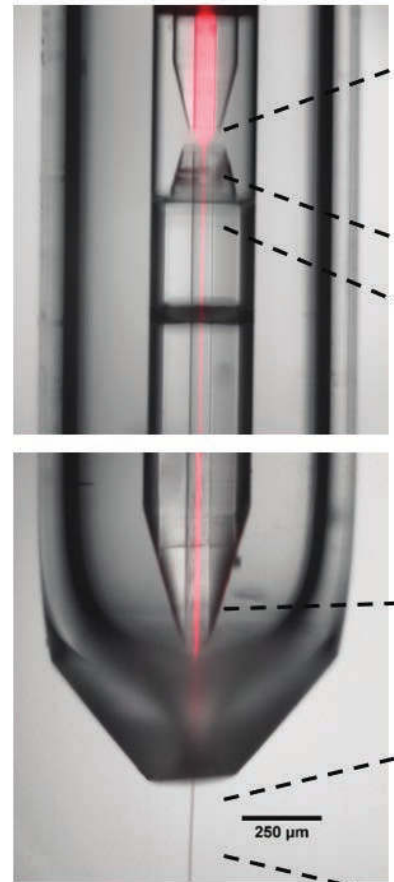
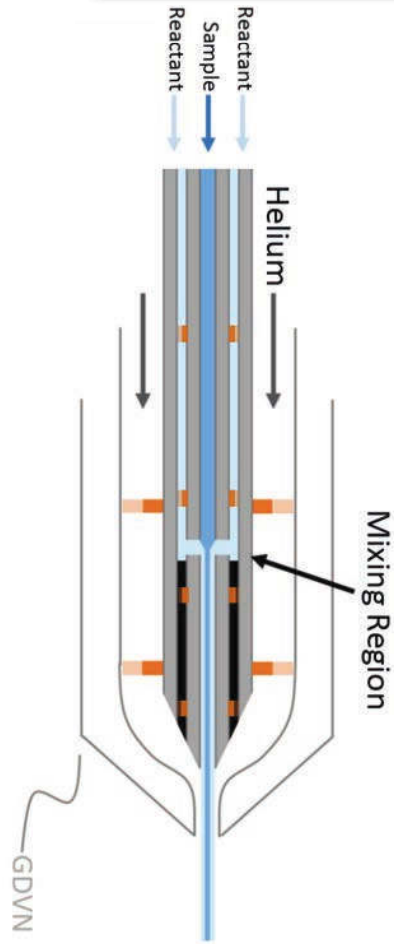

①

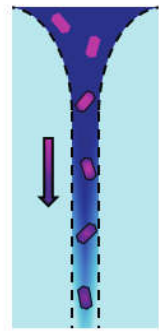

Mixing Region:
Chemical in outer stream diffuses into focused crystal flow and soaks into crystals.

②

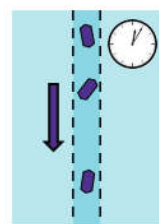

Delay Region:
Reaction commences and proceeds for time set by flow speed (shortest delay <1 ms)

③

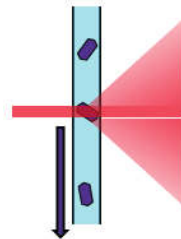

Free Jet:
Protein crystals probed by x-rays at set delay times to time-resolve reaction

B, @#[#-%@QFEc 98 "2) ' ") 2\$%# 56\$, / +# =%Ua_FE

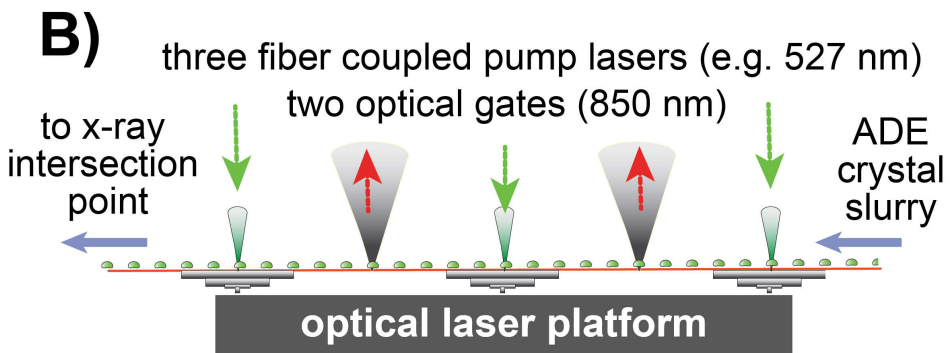

2016 - 2018

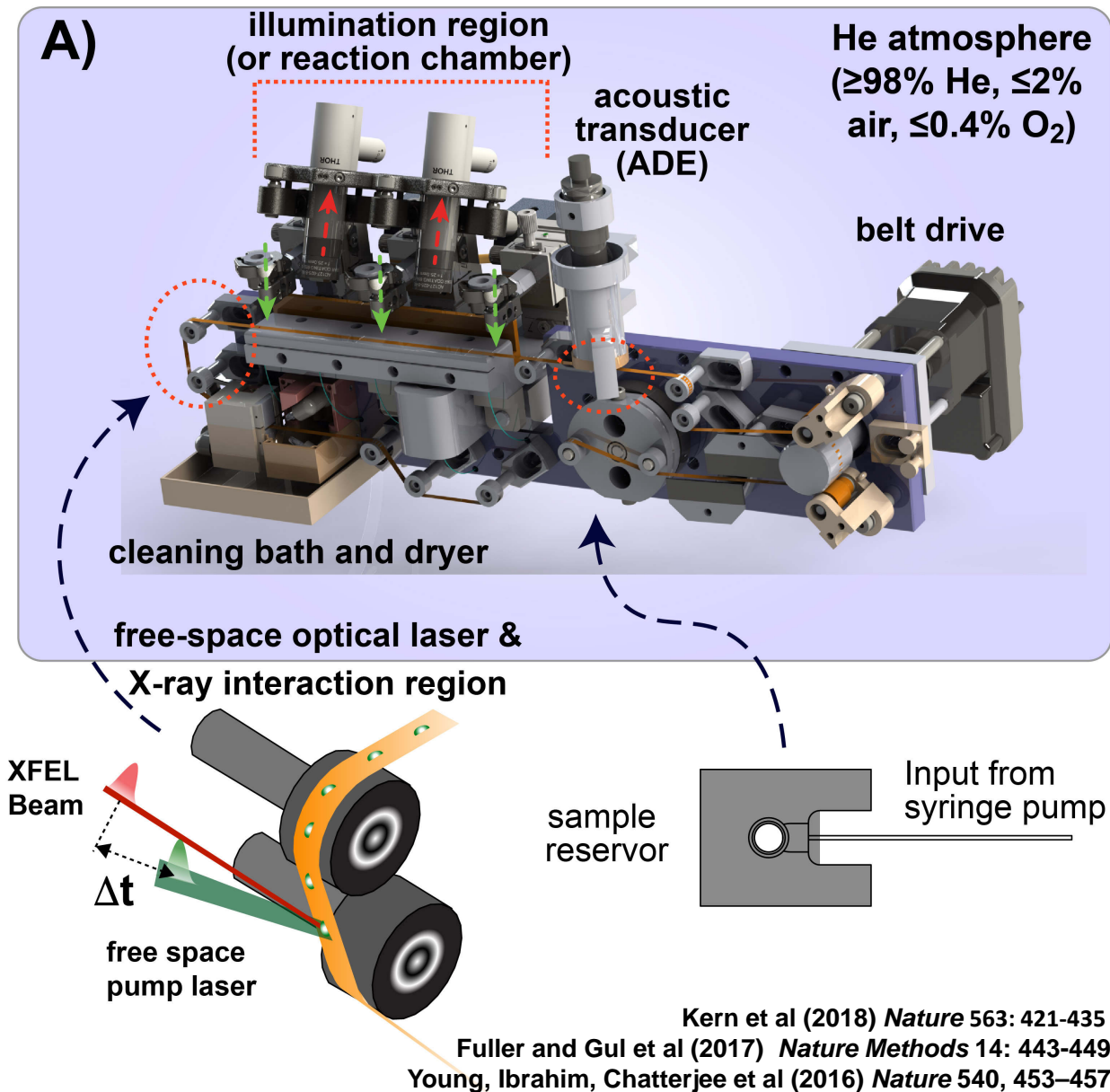
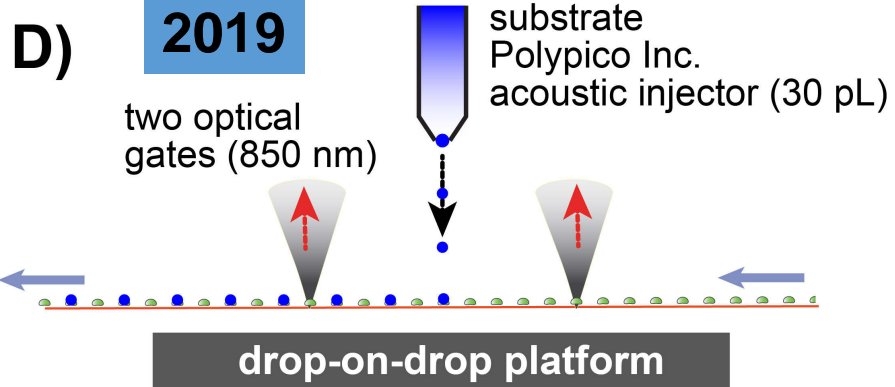
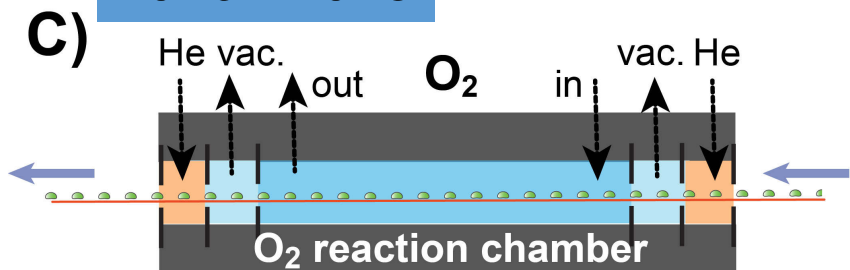

Kern et al (2018) *Nature* 563: 421-435
Fuller and Gul et al (2017) *Nature Methods* 14: 443-449
Young, Ibrahim, Chatterjee et al (2016) *Nature* 540, 453-457