

Shaping the Future of the European XFEL: Options for the SASE4/5 Tunnels
Dec. 06-07, European XFEL/Schenefeld

Hard X-ray generation at SHINE

Bo Liu

for the SHINE FEL team

2018.12.06

Acknowledgements

- ◆ Injector: Zhen Wang, Qiang Gu
- ◆ Linac: Meng Zhang, Duan Gu
- ◆ Switchyard: Si Chen
- ◆ FEL: Haixiao Deng, Chao Feng, Tao Liu, Kaishang Zhou

- ◆ Dong Wang, Zhentang Zhao

- ◆ Lots of help from project management team

Outline

- ◆ Introduction to SHINE project
- ◆ Injector
- ◆ Main Linac
- ◆ Beam Switchyard
- ◆ FEL lines
- ◆ Summary and Outlook

Introduction

Shanghai High repetition rate XFEL and Extreme light facility (SHINE)

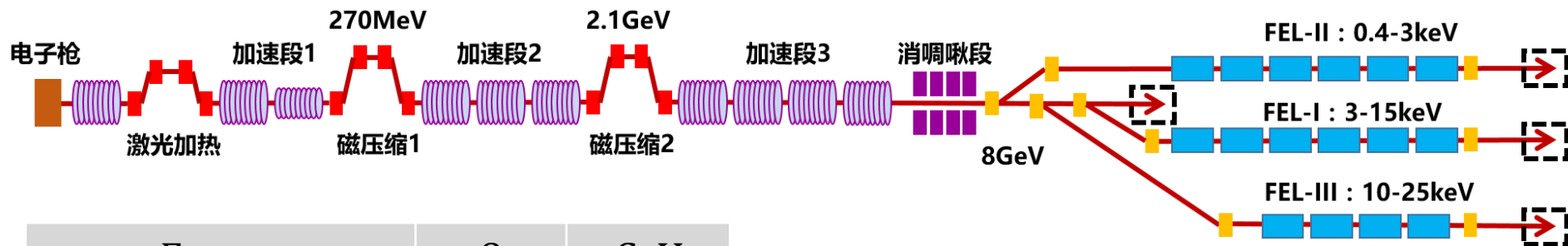

Energy	8	GeV
Slice energy spread	<0.01	%
Frequency	1	MHz
Peak current	1.5	kA
Norm. emittance	0.4	μm
Pulse length	8	μm
Charge	100	pC



FEL-I	FEL-II	FEL-III
3-15keV	0.4-3keV	10-25keV
20-50fs	20-50fs	20-50fs
>1E10	>1E12	>1E9
Ver. Planar	Hor./Ver./Cir. Planar+Helical	Vert. SCU

Scope of the SHINE project

- ◆ ~3km long, 8GeV cw linac, 1MHz rep-rate, 3 FEL lines
- ◆ 3 beamlines, 0.4-25keV, ~10 stations, multi-PWs laser
- ◆ Cost/schedule: ~1.1B Euros, 7 years(2018-25)
- ◆ R&D: 0.1B Euros, most for scRF tech./ infrastructures
- ◆ Potentials: 6 undulator/beamline, ~30 stations, 100PW laser vs. XFEL collisions, gamma ray physics, etc.



SHINE accelerator layout

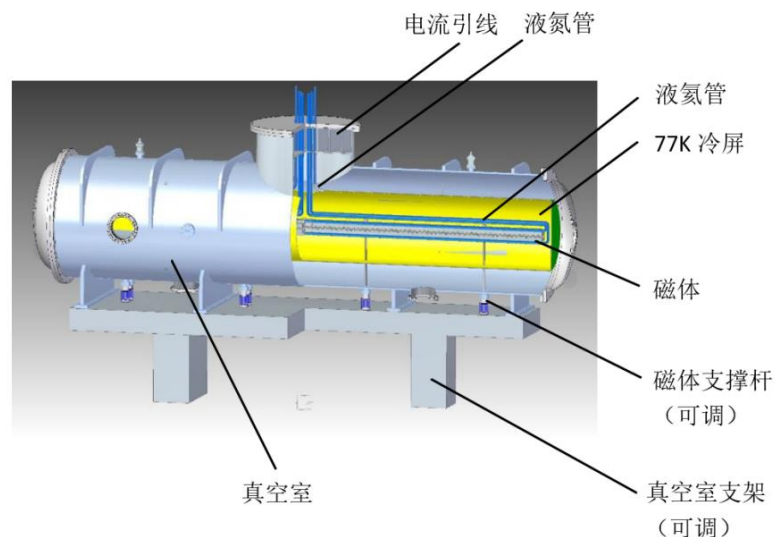
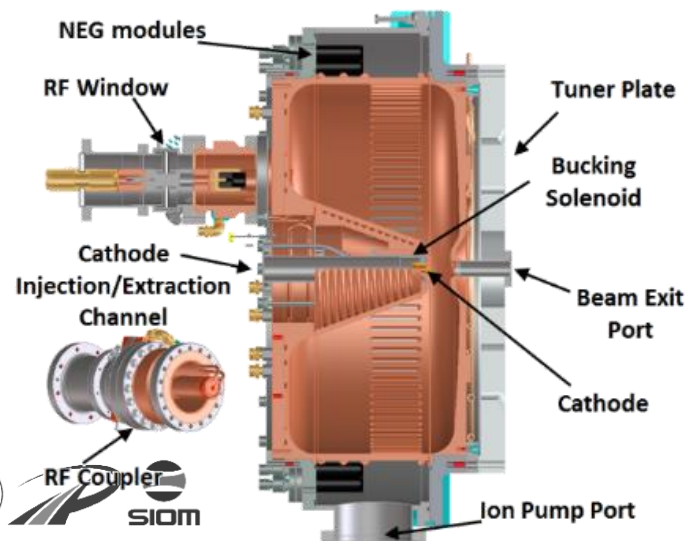
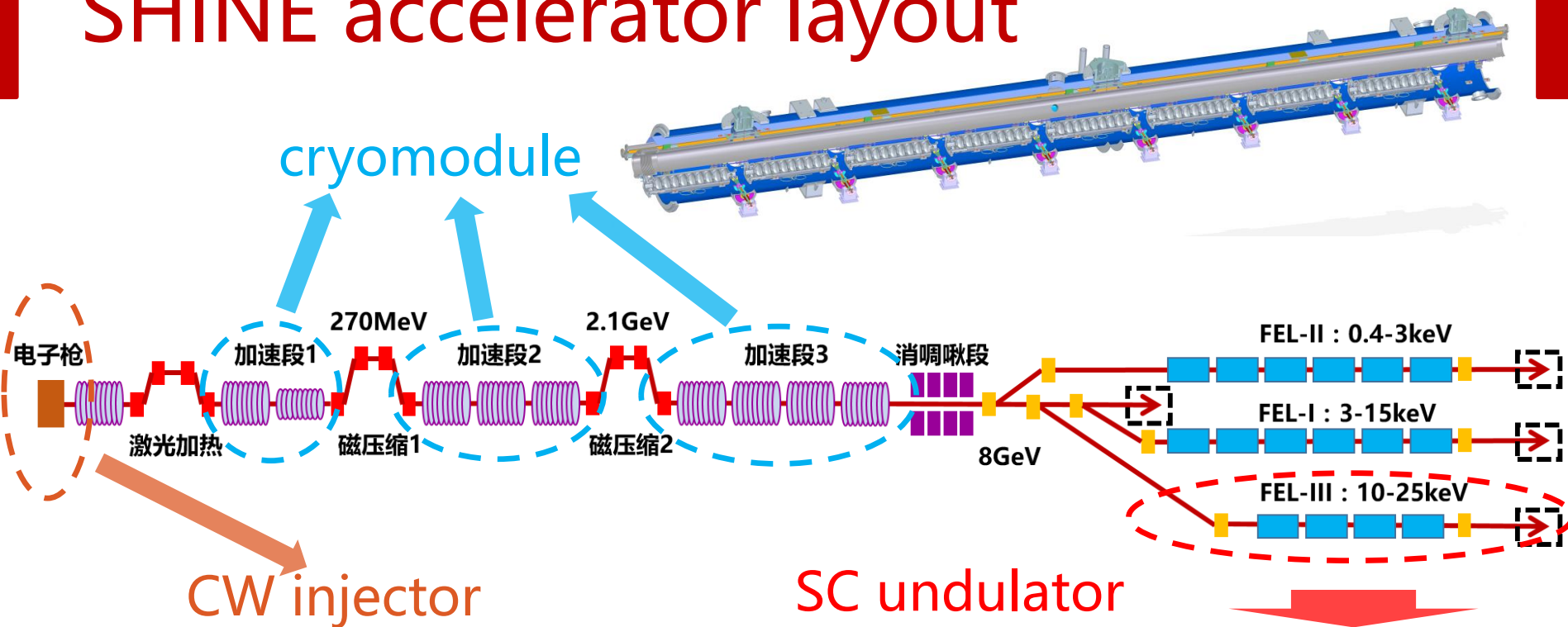

Injector

SHINE accelerator parameters

Linac parameter

Energy	8	GeV
Slice energy spread	<0.01	%
Frequency	1	MHz
Peak current	1.5	kA
Nor. Emittance	0.4	μm
Pulse length	8	μm
charge	100	pC

Injector parameter

Energy	100	90 - 120	MeV
Charge	100	10 -300	pC
Pulse length	1	0.3-3	mm
Peak current	12	4 -50	A
Frequency	0.6	0 -1	MHz
Nor. Slice emittance (rms, 95%)	0.4	0.2 -0.6	μm
Slice energy spread(rms)	1	1-5	keV

Injector test bench

Energy	60	MeV
Charge	100	pC
Pulse length	1	mm
Peak current	12	A
Nor. Slice emit. (95%)	0.4	μm
frequency (gun)	0.6	MHz
Aver. current (gun)	0.06	mA



Injector layout

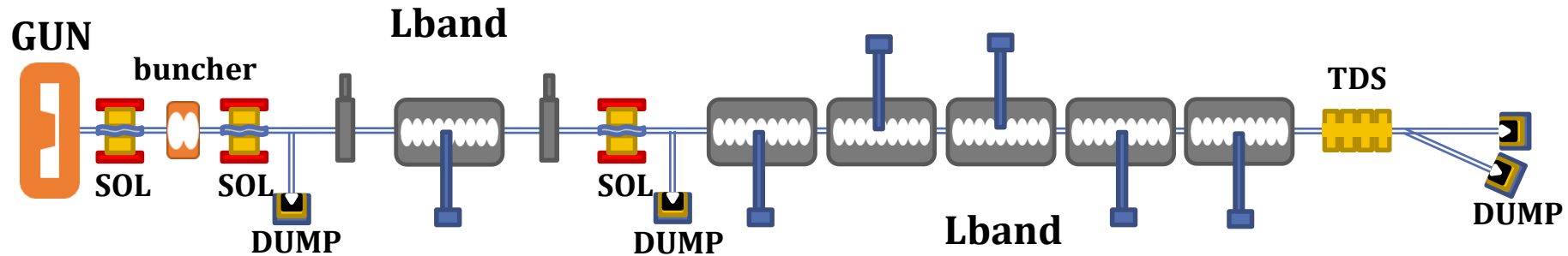

- ◆ VHF gun: 162.5MHz, 0 - 750kV, NC, CW
- ◆ buncher: 1.3GHz, 0 - 2.4MV/m, NC, CW
- ◆ L-band: 1.3GHz, 9-cells, 0 - 12MV/m
- ◆ L-band: 1.3GHz, 9-cells, 0 - 16MV/m
- ◆ TDS: 2998MHz, 0 - 3MV, NC, 5Hz
- ◆ solenoids: 0 - 0.15T, movers
- ◆ Beam diagnostics: charge + position + energy + emittance

Parameter optimization

Genetic algorithm + ASTRA

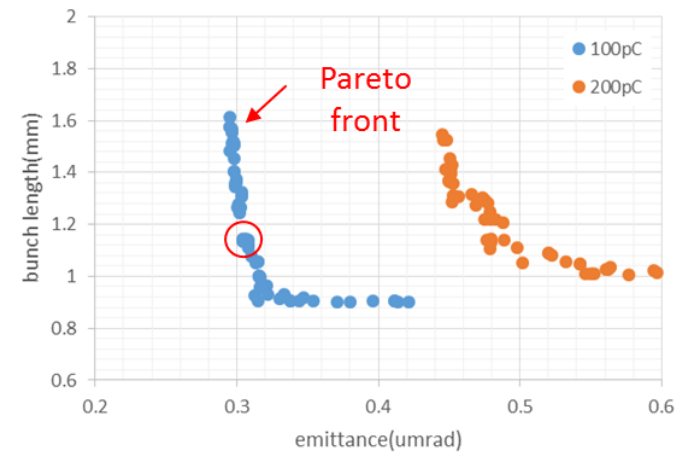

objective	Bunch length (a) , emittance (b)
constant	
Gun	volt=750kV, phase=90°
cathode	Thermal emittance=1μmrad/mm
variable	
Drive laser	Beam spot size (1) , pulse length (2)
solenoid (×3)	Mag. field (3-5) , position (6-8)
Buncher	volt (9) , phase (10) , position (11)
Single cryomodule	volt (12) , phase (13) , position (14)
Cryomodule	1# volt (15) , 1# phase (16) , 2-5# volt. (17) , position (18) *

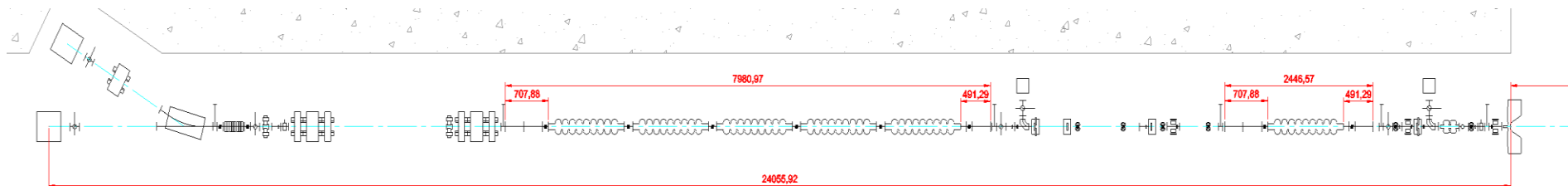

Injector beam parameters

Parameter evolution:

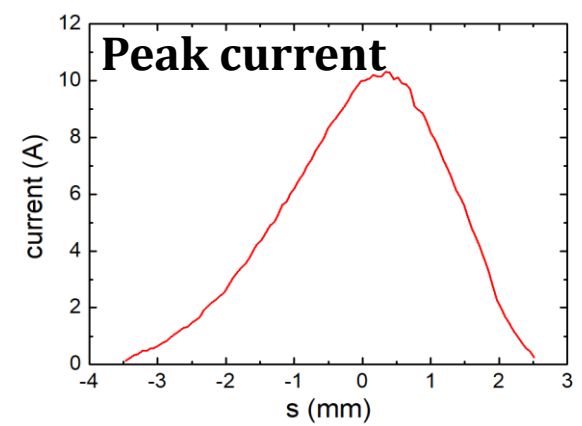
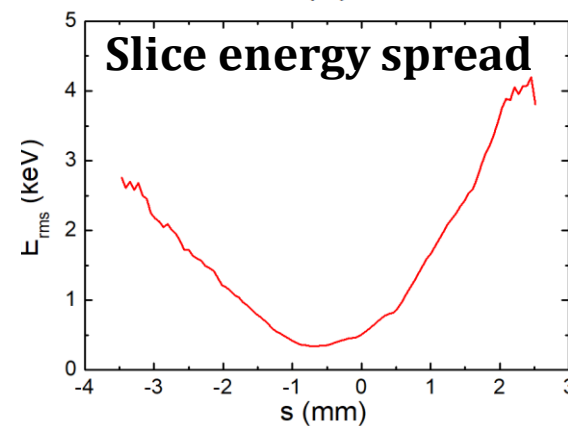
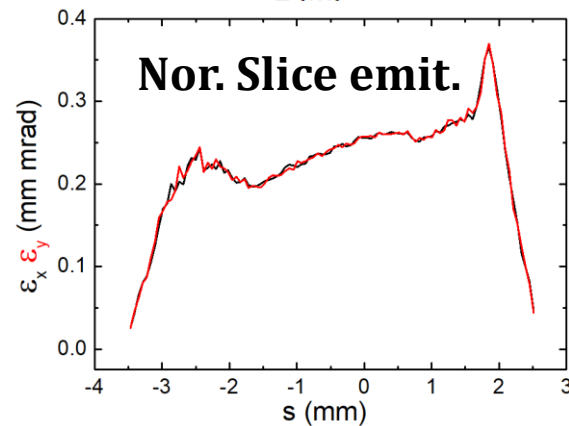
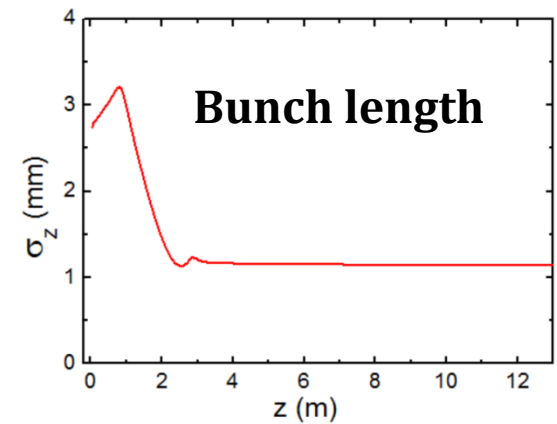
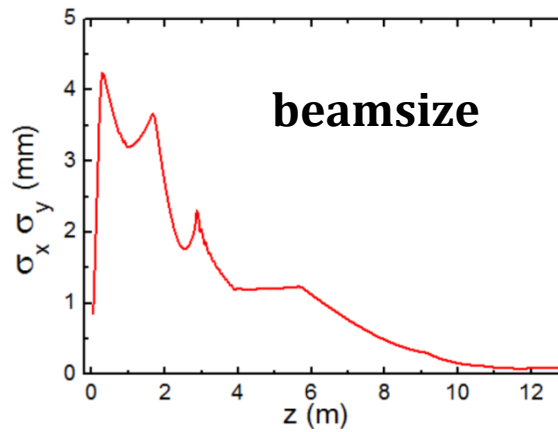
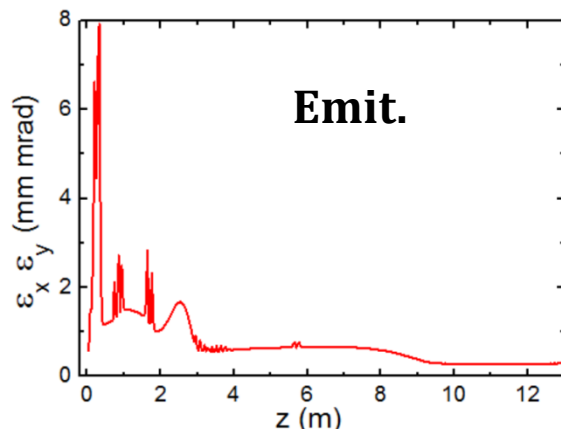

Injector error study

	X (mm)	Y (mm)	Yaw (mrad)	Pitch (mrad)
VHF gun	0.075	0.075	0.15	0.15
Buncher	0.075	0.075	0.5	0.5
L-band	0.25	0.25	0.25	0.25
Solenoid	0.05	0.05	0.3	0.3
Drive laser	0.01	0.01	-	-

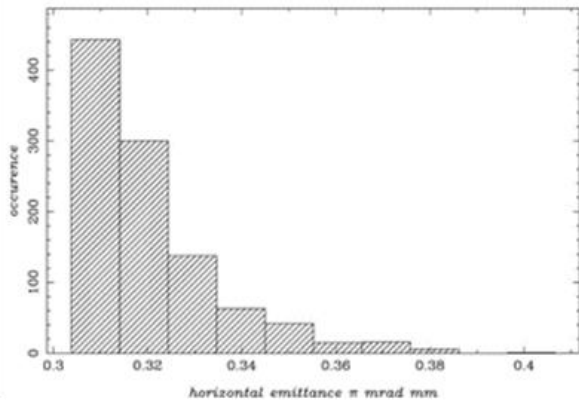

emittance (0.015 μ mrad)

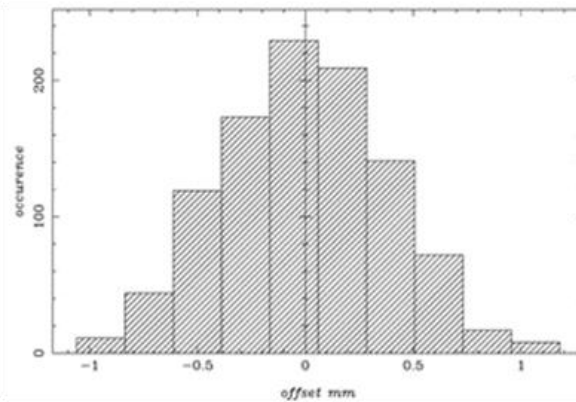

position (0.38mm)

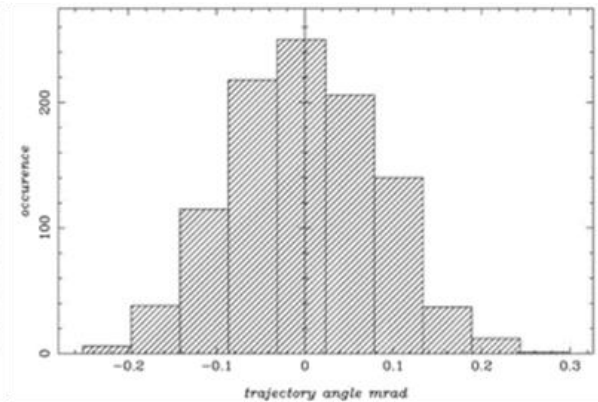

angle (0.084mrad)

Injector long. stability analysis

Stability of peak current, beam energy, arrival timing with the jitters of drive laser, gun, buncher, accelerators.

			dI(%)	dE(0.01%)	dt(fs)
Qbunch	2	%	0.759	-0.185	-46.4
Toff	20	fs	0.007	-0.017	-5.6
Trms	2	%	2.130	0.254	-7.7
Phi_gun	0.04	deg	-0.036	0.003	6.7
E_gun	0.02	%	0.161	-0.143	-61.8
Phi_buncher	0.02	deg	0.046	-0.096	-36.8
E_buncher	0.02	%	0.044	0.000	-6.2
Phi_L0-0_1	0.02	deg	-0.028	0.007	1.7
E_L0-0_1	0.02	%	0.005	0.148	71.7
phi_L0-1_1	0.02	deg	-0.001	0.007	-35.5
E_L0-1_1	0.02	%	0.000	0.304	-57.8
phi_L0-1_2	0.02	deg	0.000	0.010	15.4
E_L0-1_2	0.02	%	0.000	0.377	-34.0
phi_L0-1_3~5	0.02	deg	0.000	0.011	0.0
E_L0-1_3~5	0.02	%	0.000	0.378	0.0
			2.268	1.114	136.6

Main Linac

Main Linac

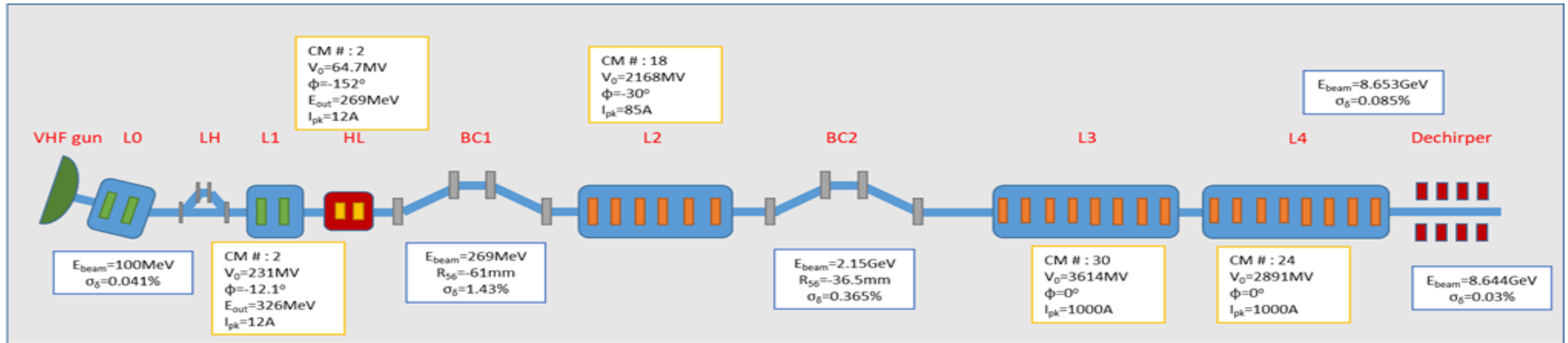

Parameters	Value
Electron beam energy (GeV)	8
Bunch charge (pC)	10-300
Rep. rate (MHz)	0-1
Normalized slice emittance in transverse (mm·mrad)	0.2-0.7
Peak current (A)	500-3000
Slice energy spread in rms	<0.01%

Bunch compression scheme

The locations of the BC1 and the BC2 are determined based on the optimization of the beam stability and the beam brilliance with the collective effects taken into account. The first stage compressor (BC1) is closed to the injector in order to minimize the effect of the transverse wakefield by compressing the beam as earlier as possible when the beam energy is low. On the other hand, in the low energy regime, the beam is more sensitive to the collective effects such as space charge. To compromise, the beam energy at BC1 is chosen as 270 MeV.

The energy at the second bunch compressor BC2 is chosen as 2.1 GeV to suppress the CSR effect during compression and to optimize the beam stability performance

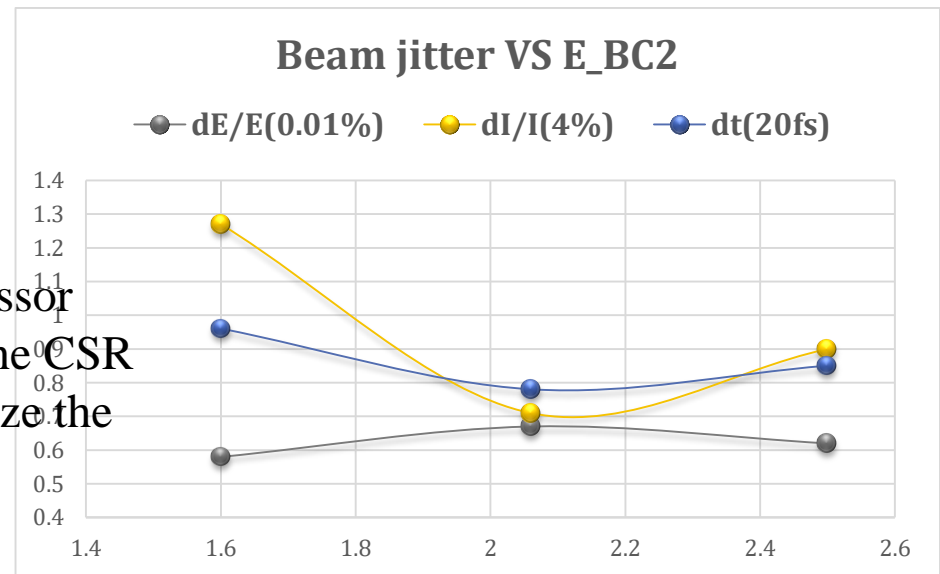

Linac Lattice and beam transport



SHINE MAIN LINAC Lattice. Ver=1.0-180815

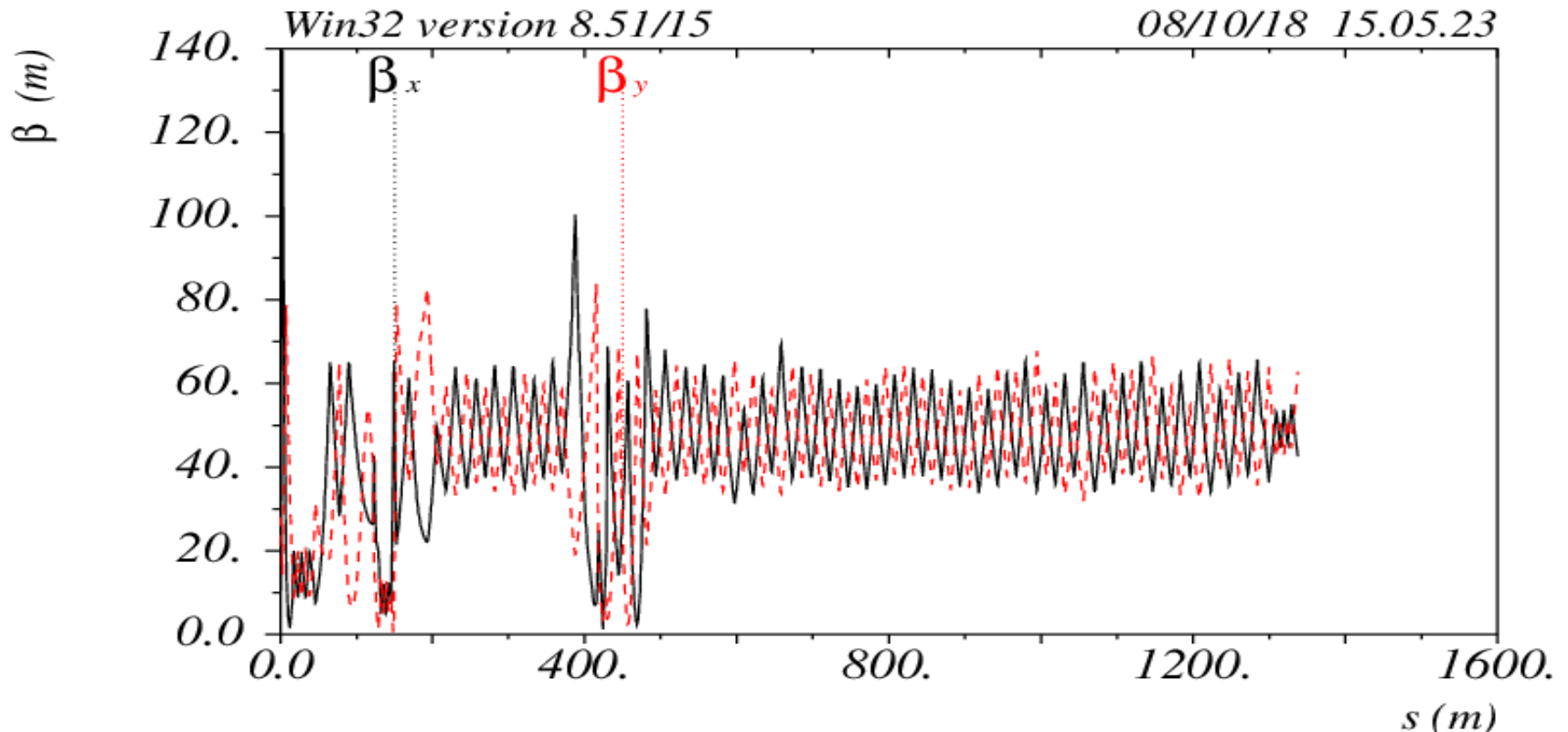

L1 section

- ◆ Three 12 m long standard cryomodules (CM01~03)
- ◆ Two 3.9GHz high harmonic cryomodules (CMH1 and CMH2)
- ◆ Phase advance per cell: 45 degree
- ◆ Total length of L1 linac: 55 m

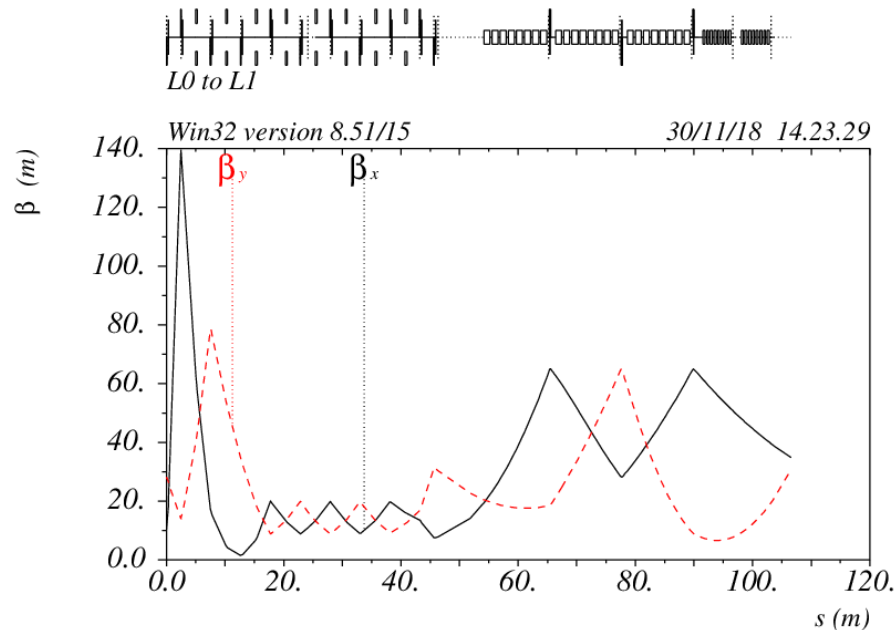

BC1 section

	Unit	BC1
Nominal beam energy	MeV	250
Energy spread	%	1.44
Compression factor		7
R56	mm	-55
Total length (B1-B4)	m	7.466
Drift length between 1st & 2nd (3rd & 4th)	m	2.45
Drift length between 2nd&3rd	m	1.75
Length of chicane dipoles	m	0.2
Bend angle	°	5.9
Magnetic field	T	0.42
Maximum dispersion	m	0.28

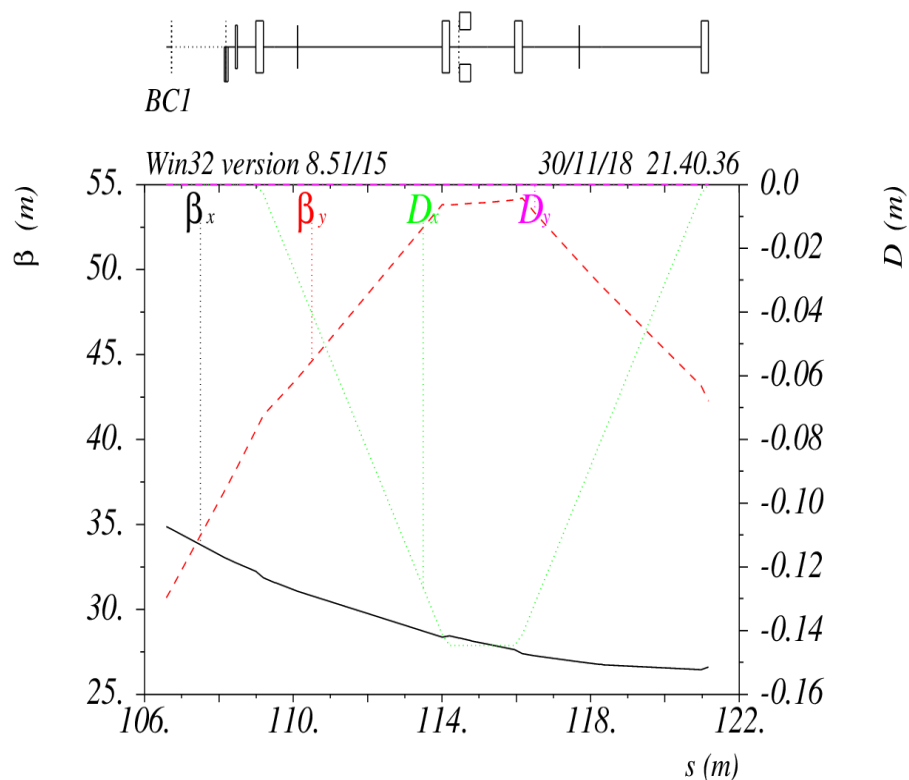

L2 section

- ◆ Eighteen 12m long standard cryomodules (CM01~03)
- ◆ Phase advance per cell: 30 degree
- ◆ Total length of L2 linac: 230 m

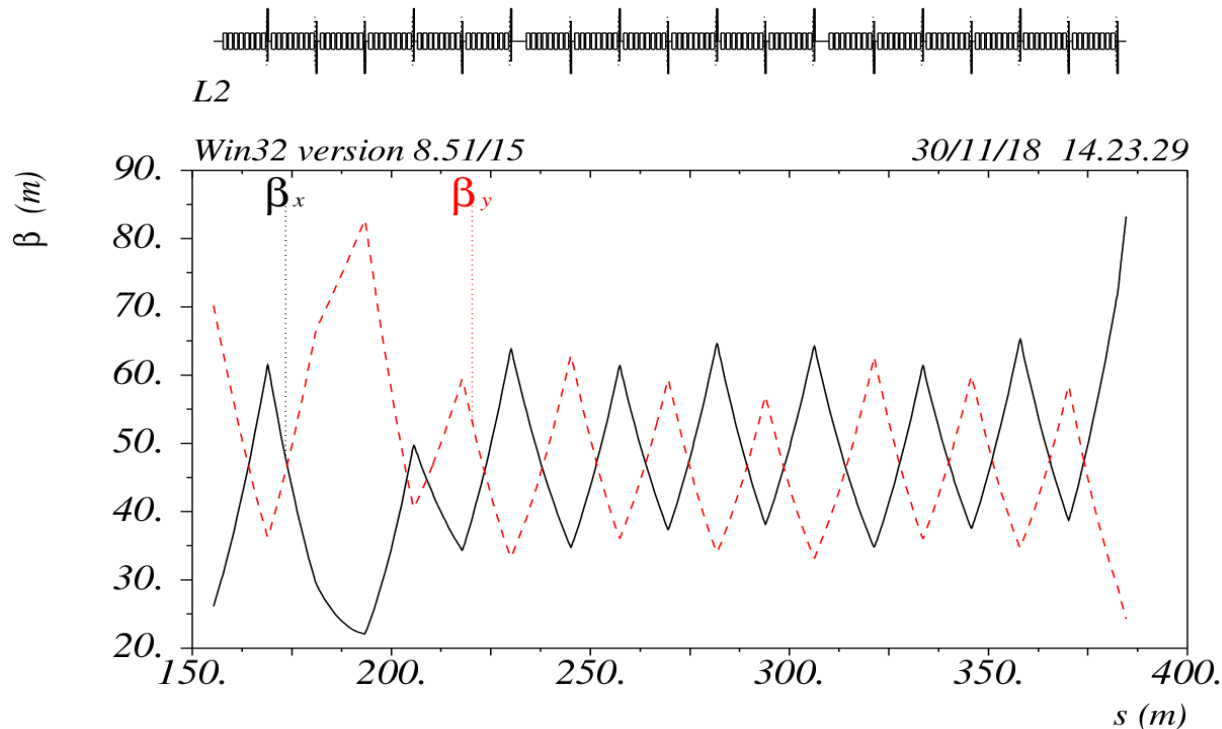

BC2 section

	Unit	BC2
Nominal beam energy	MeV	2150
Energy spread	%	0.62
Compression factor		15
R56	mm	-36
Total length (B1-B4)	m	23.686
Drift length between 1st & 2nd (3rd & 4th)	m	9.87
Drift length between 2nd&3rd	m	1.75
Length of chicane dipoles	m	0.55
Bend angle	°	2.4
Magnetic field	T	0.547
Maximum dispersion	m	0.44

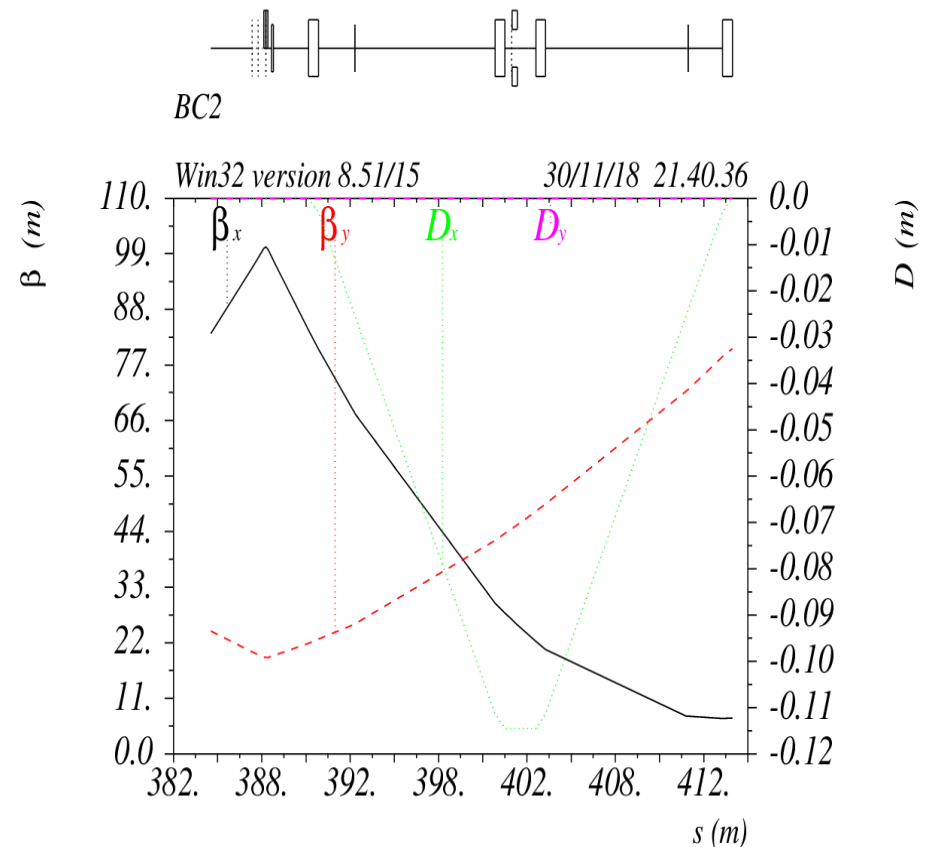

L3&L4 section

- ◆ L3: 24 cryomodules (CM22~45)
- ◆ Break: reserved space (third bunch compressor or an extraction line)
- ◆ L4: 30 cryomodules (CM46~75)
- ◆ Phase advance per cell: 30 degree

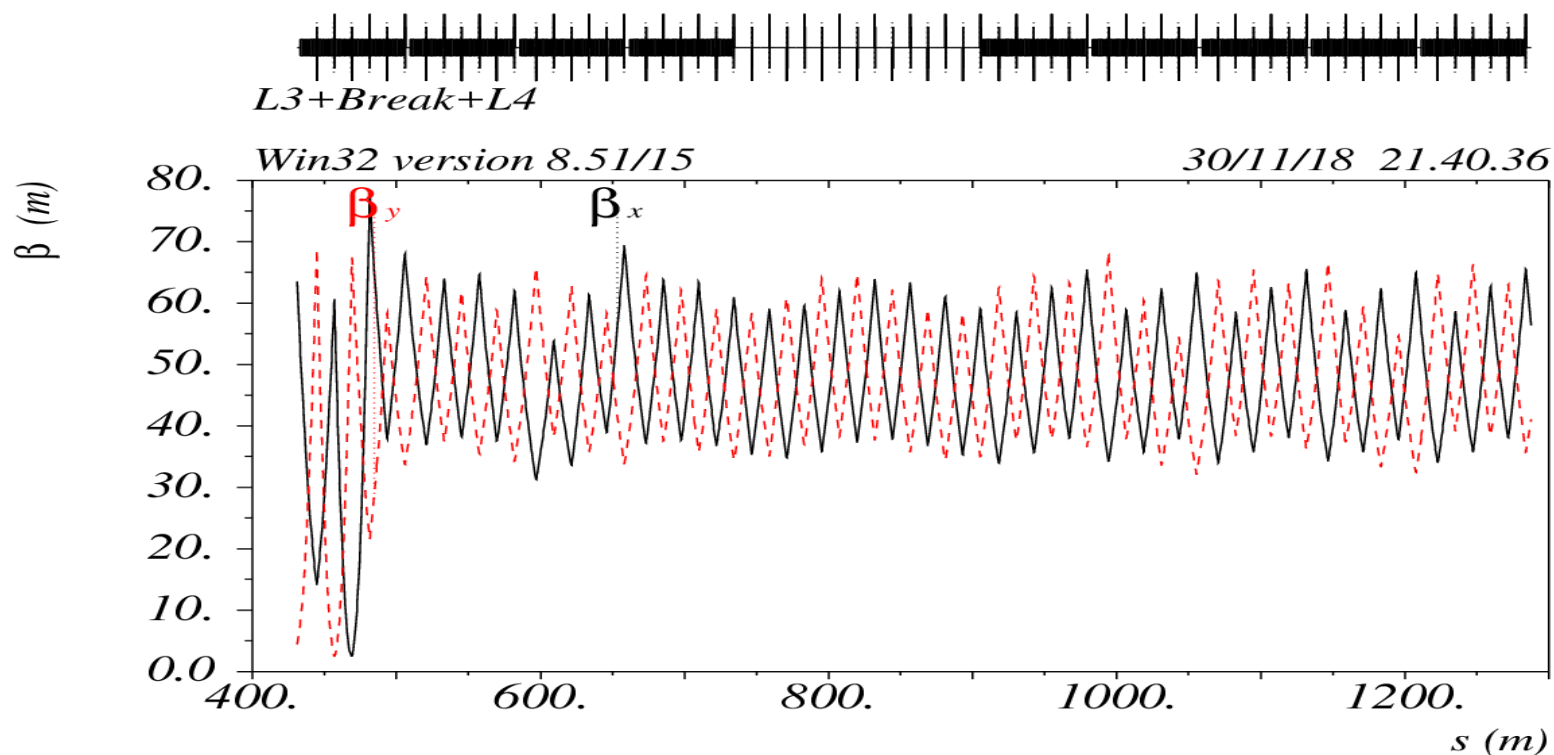

Dechirper with Passive Structures

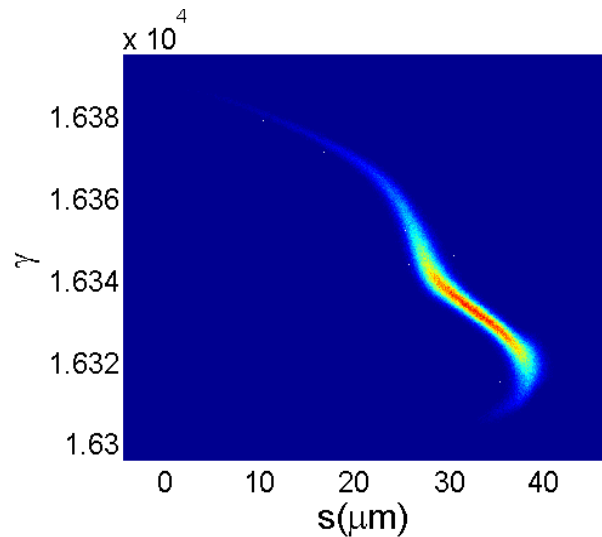
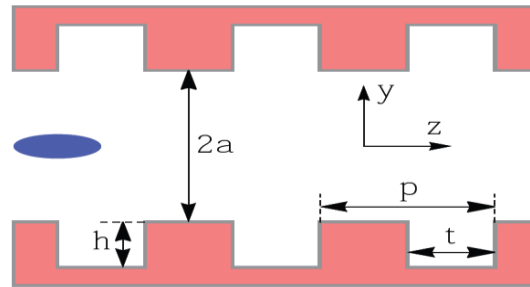

Without corrugated dechirper

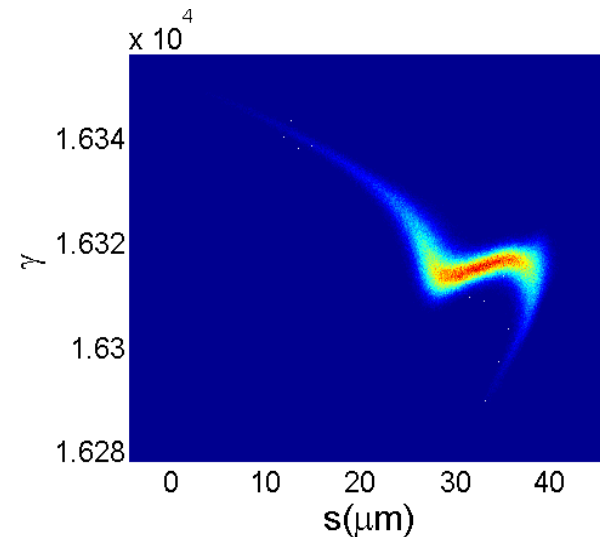

With corrugated dechirper

Longitudinal orbit feedback

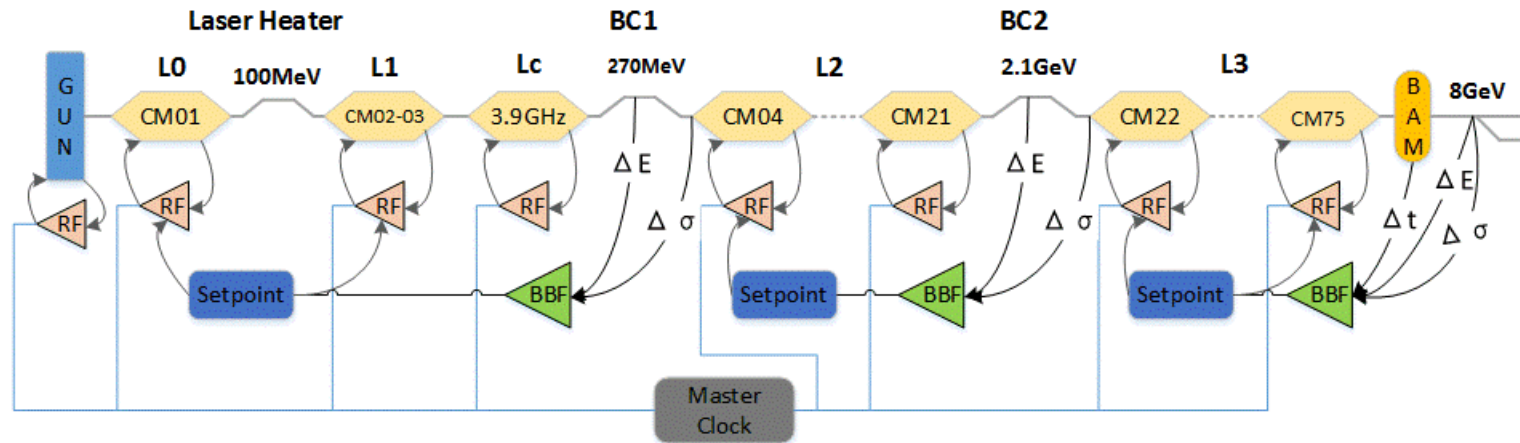

Loop	Sensor	Actuator
Charge	BPM before BC1	Laser intensity
Injector energy	Laser Heater BPM	L0 RF I/Q component
BC1 energy/bunch length	BC1 BPM BC1 BLM	L1 RF I/Q component
BC2 energy/bunch length	BC2 BPM BC2 BLM	L2 RF I/Q component
Energy at Linac exit	Switchyard BPM	L3 RF I/Q component
Beam arrival time	BAM	RF phase
bunch length at Linac exit	Switchyard BLM	RF phase

Beam Switchyard

Beam Switchyard – Overview

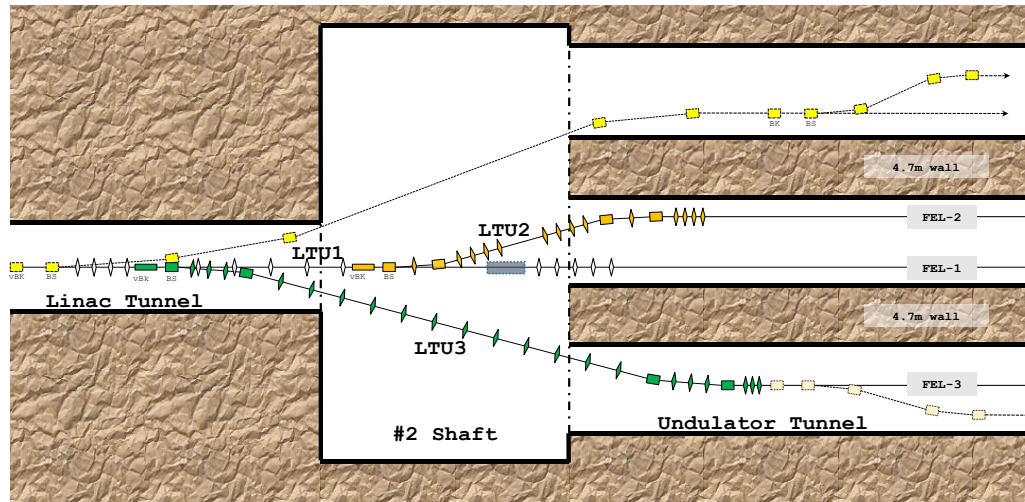

Parameters	Values	Units
Beam Energy	8	GeV
Rep. rate	1	MHz
Norm. Emittance	<0.45	$\mu\text{m}\cdot\text{rad}$
Bunch Charge	100	pC
Peak Current	1500	A
Energy Spread	0.01%	

- Linac tunnel → #2 Shaft (88m×32m) → Three undulator tunnels
- Three FEL undulator lines (extensible for 6 or more):
 - FEL-1 & FEL-2 in mid-tunnel;
 - FEL-3 in one side-tunnel
- Two beam distribution system:
 - Between LTU1 and LTU3
 - Between LTU1 and LTU2
- Beam switchyard with 3 branches:
 - LTU3: deflection branch, linac → FEL-3
 - LTU1: straight branch, linac → FEL-1
 - LTU2: deflection branch, linac → LTU1 → FEL-2

Beam Switchyard – Optics design

- Requirement: **Fast; Stably; Accurately; Efficiently; etc.**
- Bunch-by-bunch: vertical fast kicker ($\sim 1\text{mrad}$, 1MHz) + DC Lamberson septum

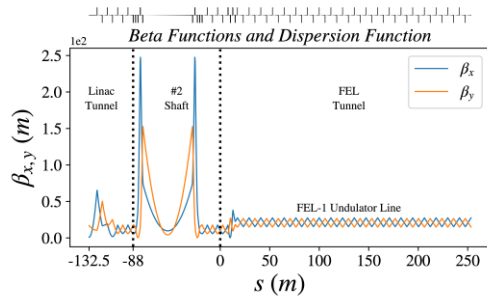

LTU1 & FEL-1

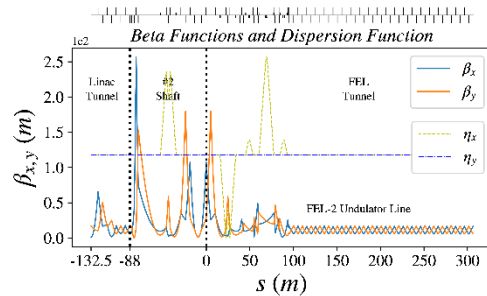

LTU2 & FEL-2

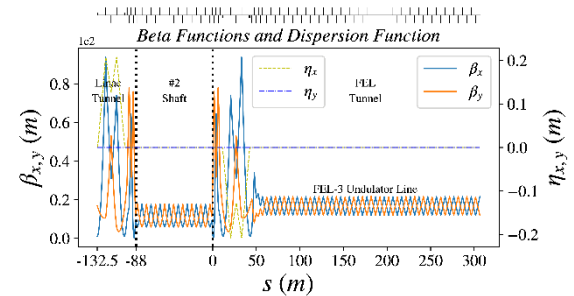

LTU3 & FEL-3

- LTU3 deflection branch:
 - Septum installed $\sim 44.5\text{m}$ in front of the exit of linac tunnel, kickers in 25m upstream;
 - Dog-leg style: DBA (3.4° , 32 m) + matching (113 m) + DBA (-3.4° , 32 m);
 - Phase advance $\Delta\phi \sim \pi$ between the two bending magnets of DBA for cancelling CSR kick.
- LTU1 straight branch:
 - 50 m long space: for kicker-septum of LTU2 and bending magnets for beam dump.
- LTU2 deflection branch:
 - Kicker-septum system installed in the first 25 m of the 50m-space in LTU1
 - Dog-leg style: DBA (3.0° , 18.4 m) + matching (48 m) + DBA (-3.0° , 18.4 m);
 - Phase advance $\Delta\phi \sim \pi$ between the two bending magnets of DBA for cancelling CSR kick.



Beam Switchyard – Tracking results

- Particle tracking by ELEGANT:
 - 1M macro-particles; CSR, ISR, LSC included; Laser-heater amplitude $\sim 6.5e-5$.
 - From the entrance of LTU3 septum
- Cancellation of the CSR induced emittance growth

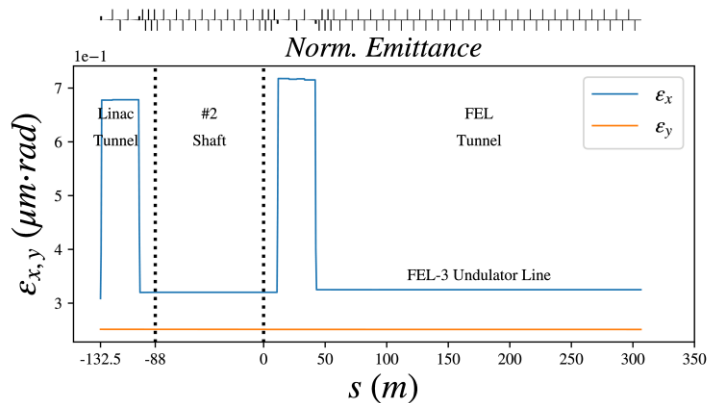

Norm. emittance in LTU3 & FEL-3

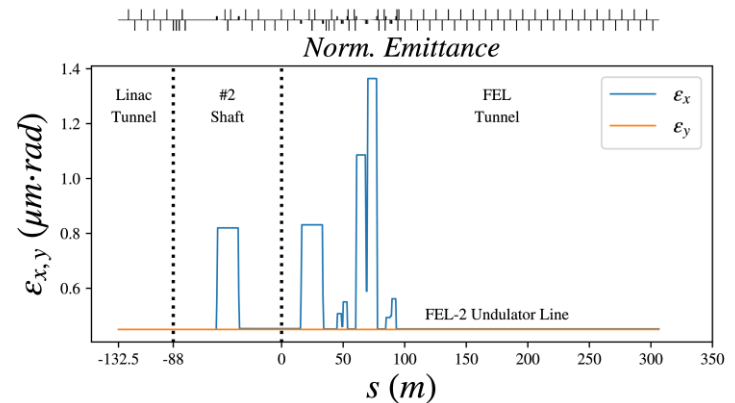

Norm. emittance in LTU2 & FEL-2

- Micro-bunching instability

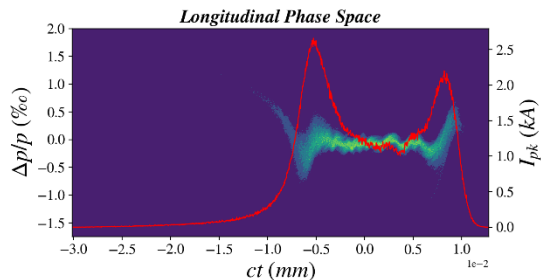

Entrance of LTU3 septum

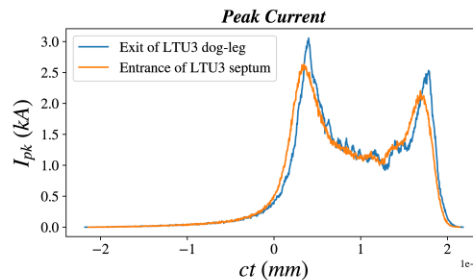

Exit of LTU3 dog-leg

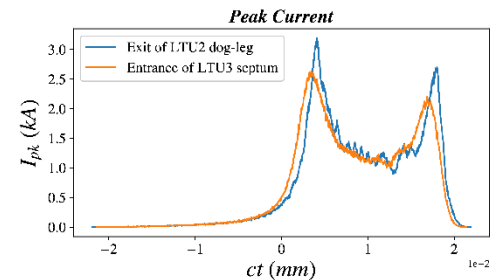

Exit of LTU2 dog-leg



FEL lines

Introduction and overview

- ◆ 3 undulator beamlines
- ◆ PMU + Superconducting Undulator
- ◆ Covering the photon energy range 0.4-25 keV
- ◆ Fully coherent X-ray generation based on self-seeding and external seeding

	FEL-I	FEL-II	FEL-III
FEL modes	SASE/HXSS	SASE/SXSS EEHG/HGHG cascading	SASE/HXSS
FEL photon energy	3-15 keV	0.4-3 keV	10-25 keV
Undulator type	Planar	Planar + EPU	SC Planar
Undulator Period	26 mm	68 mm	16 mm
Undulator length	5 m× 34	4 m× (40 + 4)	4 m× 40

Undulator system

	FEL-I	FEL-II	FEL-III
Undulator Type	Planar	Planar	Helical
Quantity	34	40	4
Period (mm)	26	68	68
Segment Length (m)	5	4	4
Min. Gap (mm)	7.2	7.2	5
Peak Field (T)	1.0	1.5	1.5/1.5/1.06

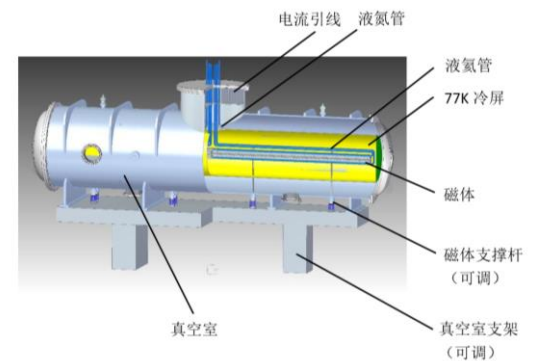
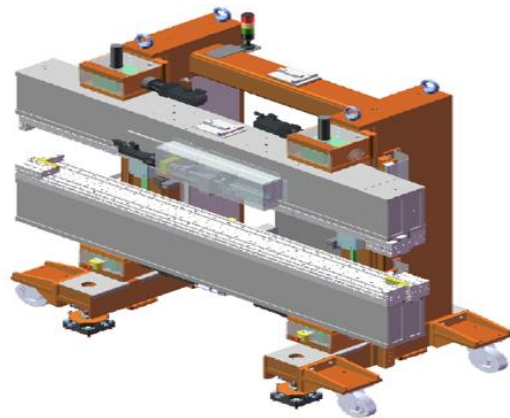
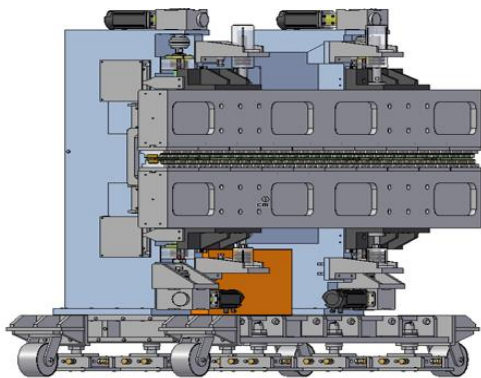

FEL parameters & operation modes

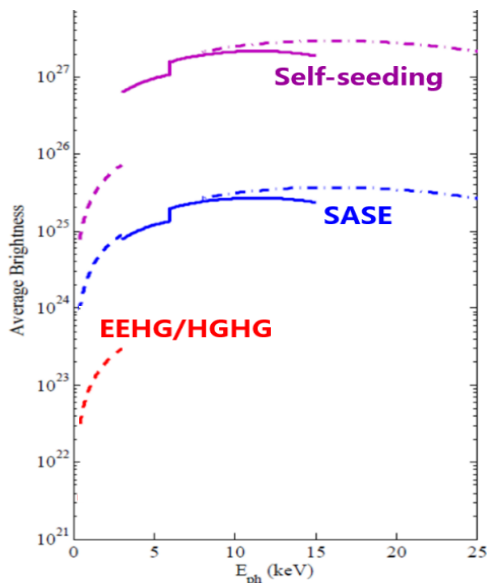
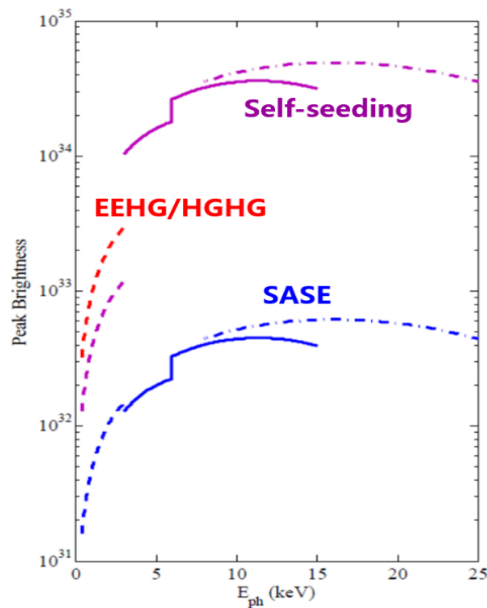

	Nominal	Objective	Unit
FEL-I			
Photon energy	3-15	3-15	keV
Photon number per pulse @ 12.4keV	$>10^{10}$	$>10^{11}$	
Max pulse repetition rate	1	1	MHz
Pulse length	20-50	5-200	fs
FEL radiation size (typical)	50	40-100	μm
FEL diffraction angle (typical)	3	2-5	μrad
FEL-II			
Photon energy	0.4-3	0.4-3	keV
Photon number per pulse @ 1.24keV	$>10^{12}$	$>10^{13}$	
Max pulse repetition rate	1	1	MHz
Pulse length	20-50	5-200	fs
FEL radiation size (typical)	60	50-120	μm
FEL diffraction angle (typical)	7	3-20	μrad
FEL-III			
Photon energy	10-25	10-25	keV
Photon number per pulse @ 15keV	$>10^9$	$>10^{10}$	
Max pulse repetition rate	1	1	MHz
Pulse length	20-50	5-200	fs
FEL radiation size (typical)	40	30-80	μm
FEL diffraction angle (typical)	2	1-4	μrad

FEL-I baseline: SASE (3-15 keV)

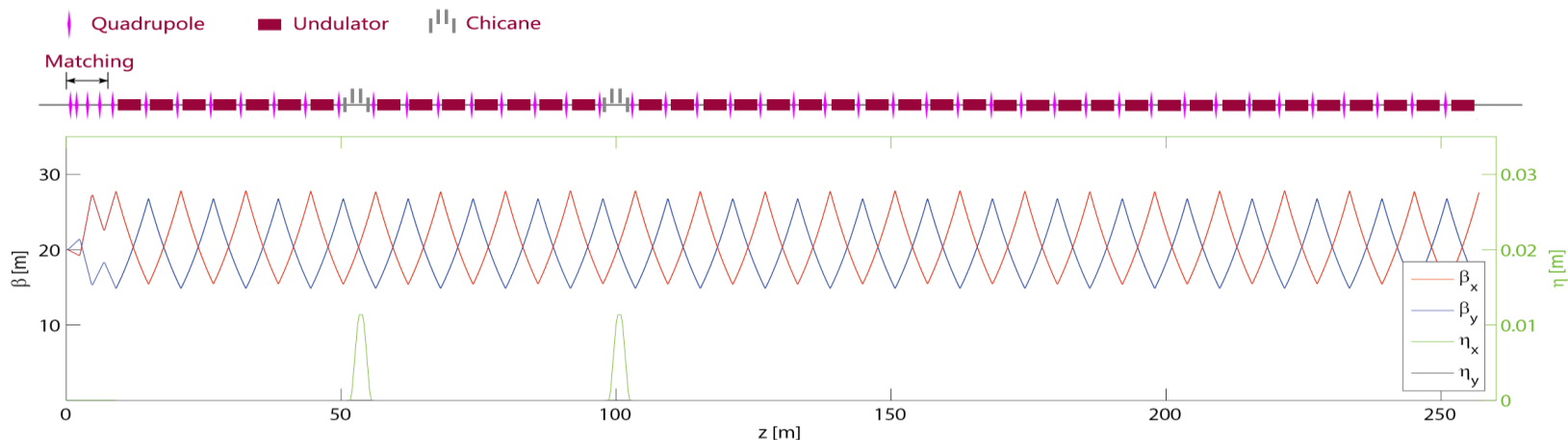

Undulators (34 segments)

Segment length	5 m
Period	26 mm
Spacing between undulator segments	1 m

Chicanes for self-seeding (2)

Total length	3.6 m
Delay	0~250 fs
Max. offset	10 mm

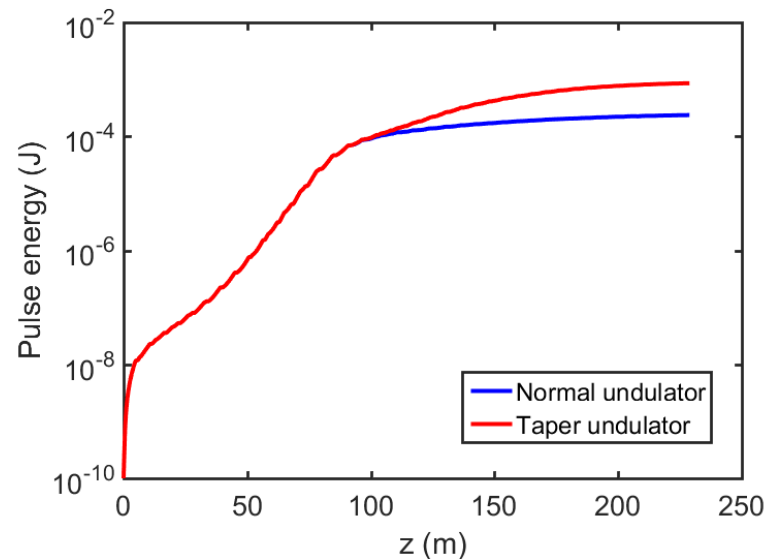

SASE@12.4 keV, charge: 100pC

FEL-I baseline: SASE (3-15 keV)

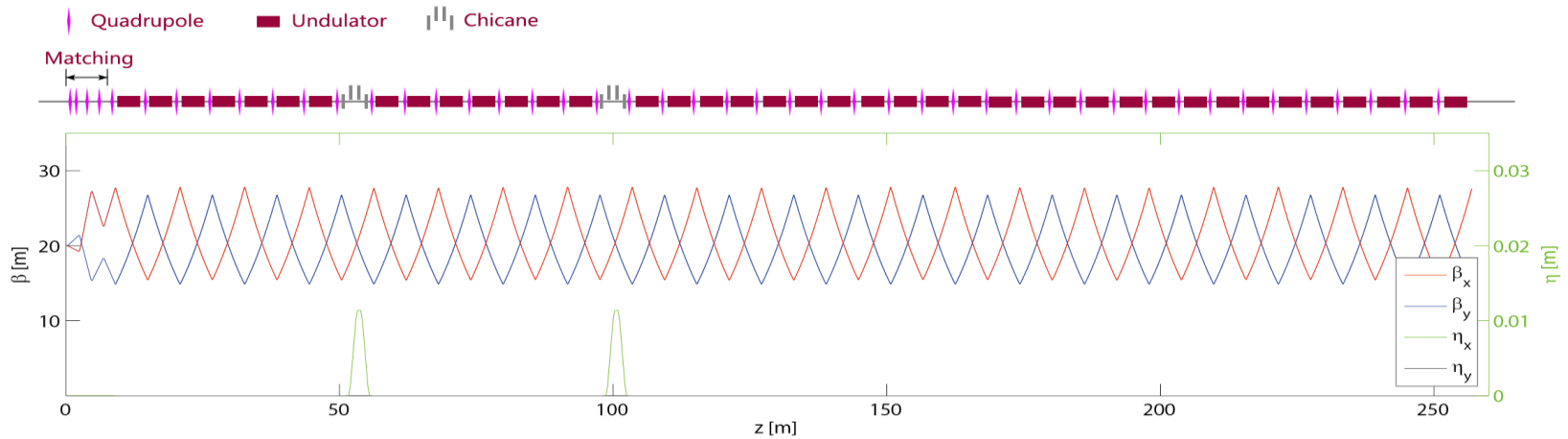

	Un-taper	Taper
Op. Mode	SASE	SASE
Photon energy	12.4keV	12.4keV
Peak power	6GW	30GW
Pulse energy	236 μ J	857 μ J
Pulse length	37fs	33fs
FEL bandwidth	0.12%	0.10%
Radiation size	50 μ m	50 μ m
Diffraction angle	4.0 μ rad	4.0 μ rad

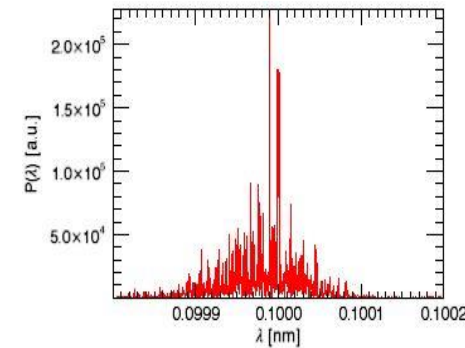
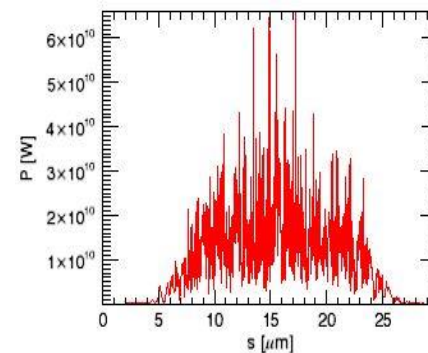
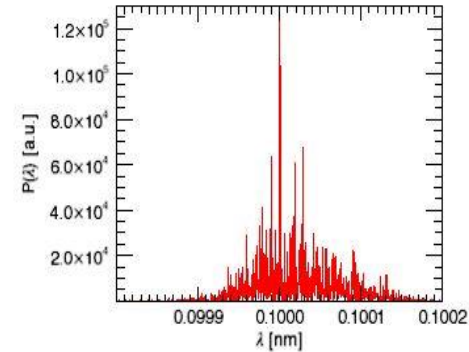
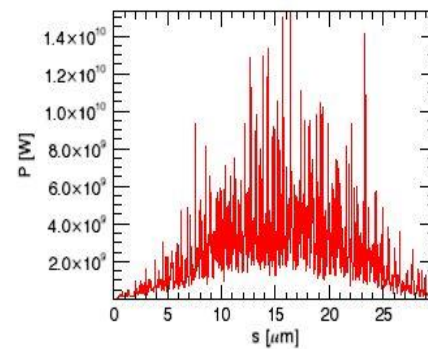

FEL-I self-seeding

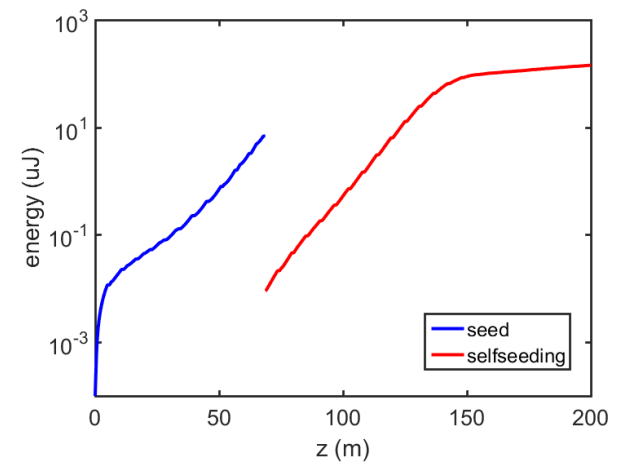
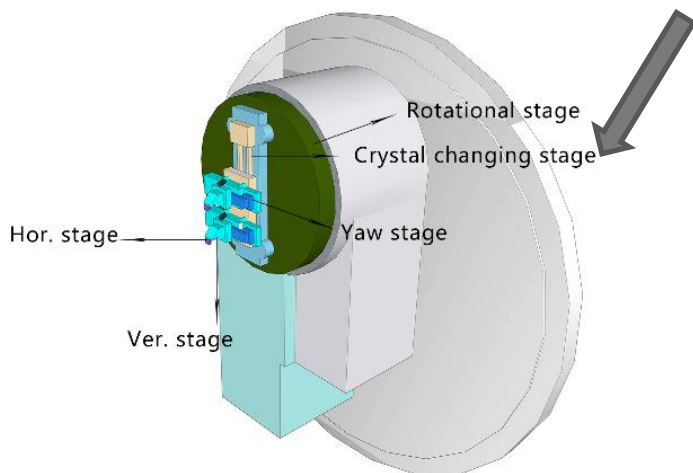
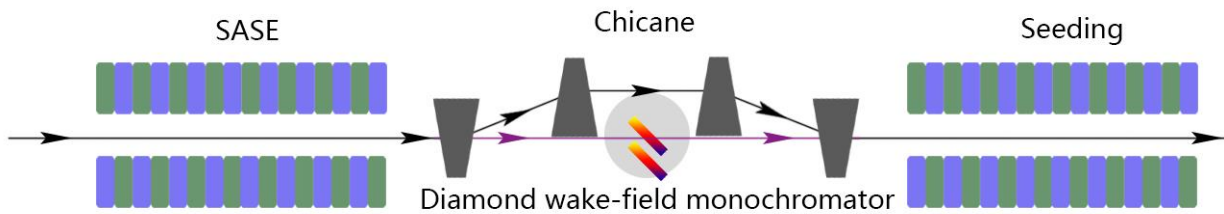

Self-seeding@12.4 keV, charge: 100pC

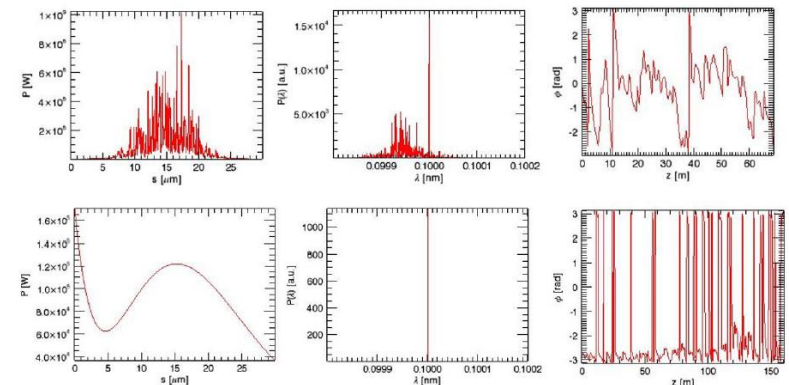

Diffraction order	C(111)	C(004)
Photon energy coverage	3~7 keV	7~20 keV
Crystal thickness	50~100μm	100μm
Crystal size	4x4mm	4x4mm
Bragg angle	46.7°	34.1°
Time delay	~50 fs	~50 fs
repetition-rate	0.1-1MHz	0.1-1MHz
SASE power	~1 GW	~1 GW
Resolution	8.17e-5	1.51e-5

FEL-I self-seeding

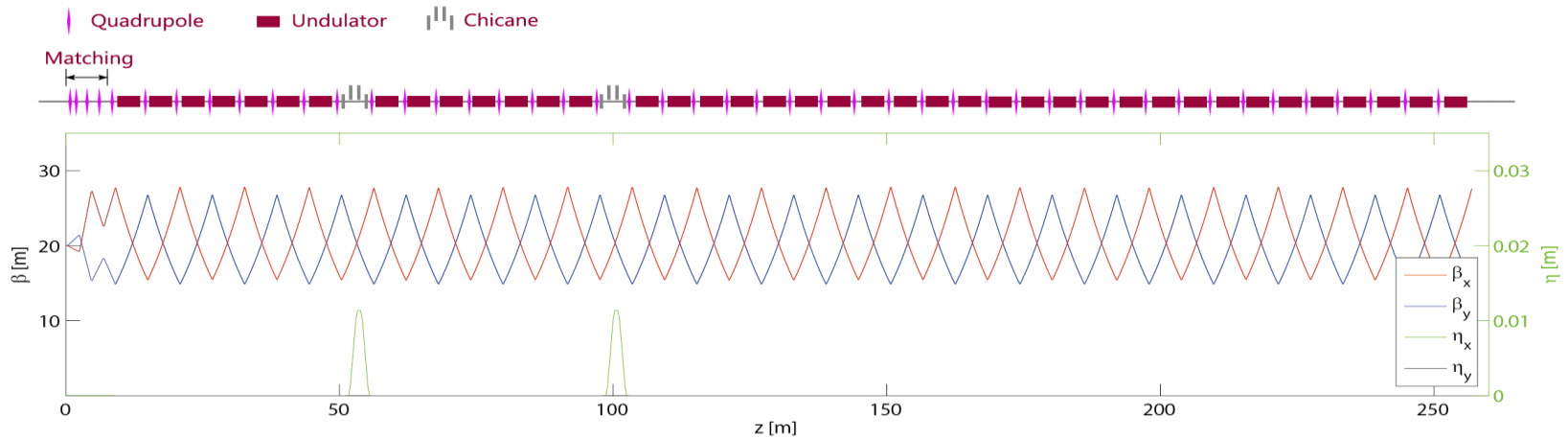

	Un-taper	Taper
Op. Mode	SS	SS
Photon energy	12.4keV	12.4keV
Peak power	4GW	10GW
Pulse energy	172μJ	315μJ
Pulse length	40fs	30fs
FEL bandwidth	0.001%	0.0008%
Radiation size	50μm	50μm
Diffraction angle	3.7μrad	3.8μrad

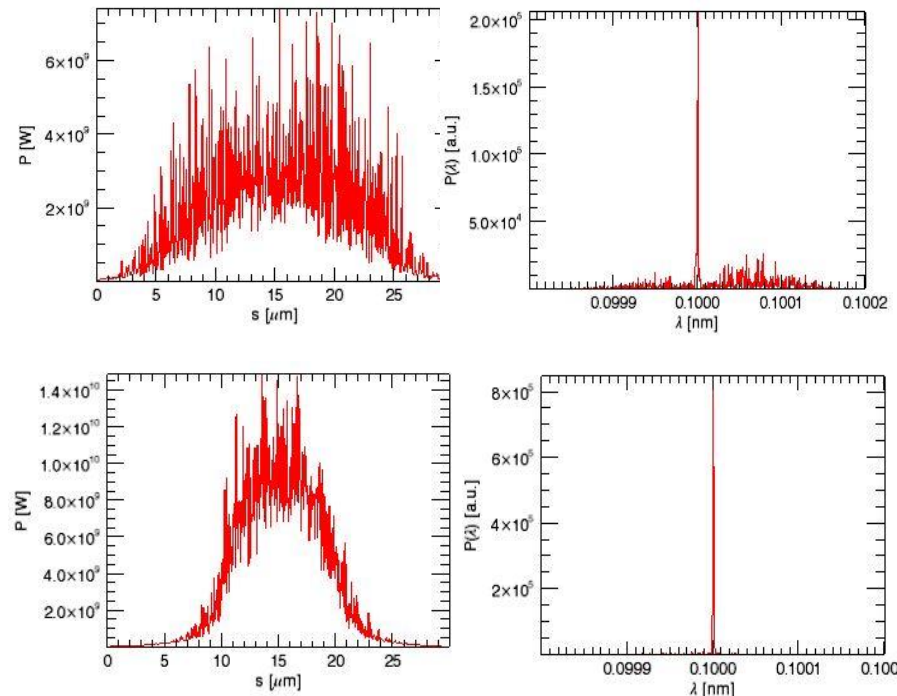

FEL-II baseline: EEHG (0.3-1.2 keV)

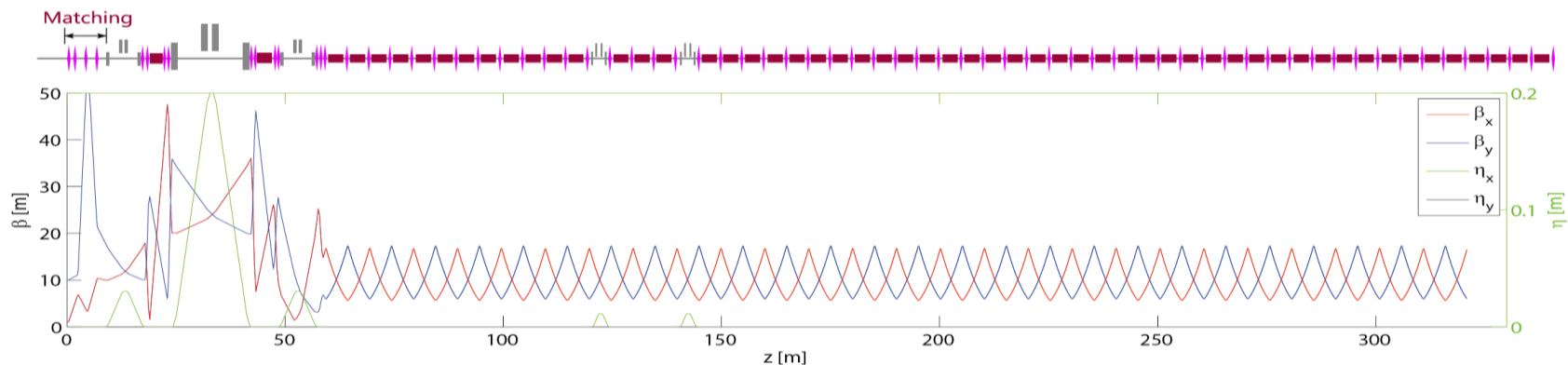

Modulator 1

Length 3.2 m

Period 16 cm

Modulator 2

Length 3.2 mm

Period 40 cm

Radiator (40 segments)

Length/segment 4 m

Period 68 mm

Chicanes (5)

Length 4.4 m (4), 16m (1)

Max. R56 0~0.5 mm (4), 0~8 mm (1)

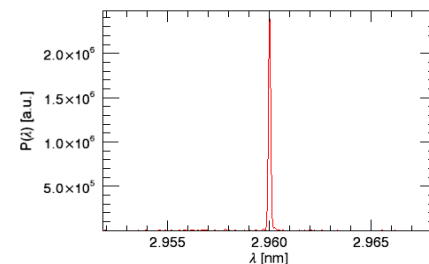
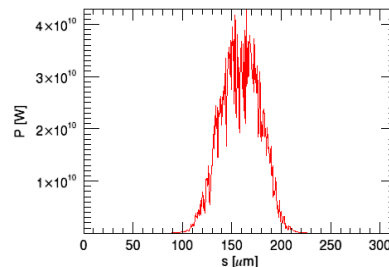
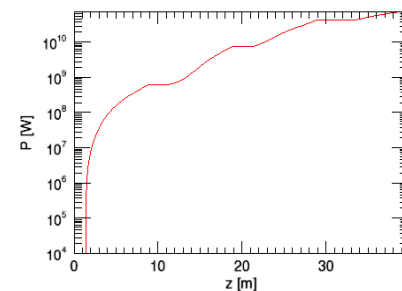
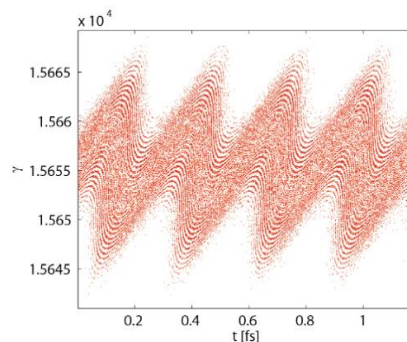

Single stage EEHG@3 nm, charge: 100pC

FEL-II baseline: EEHG-HGHG

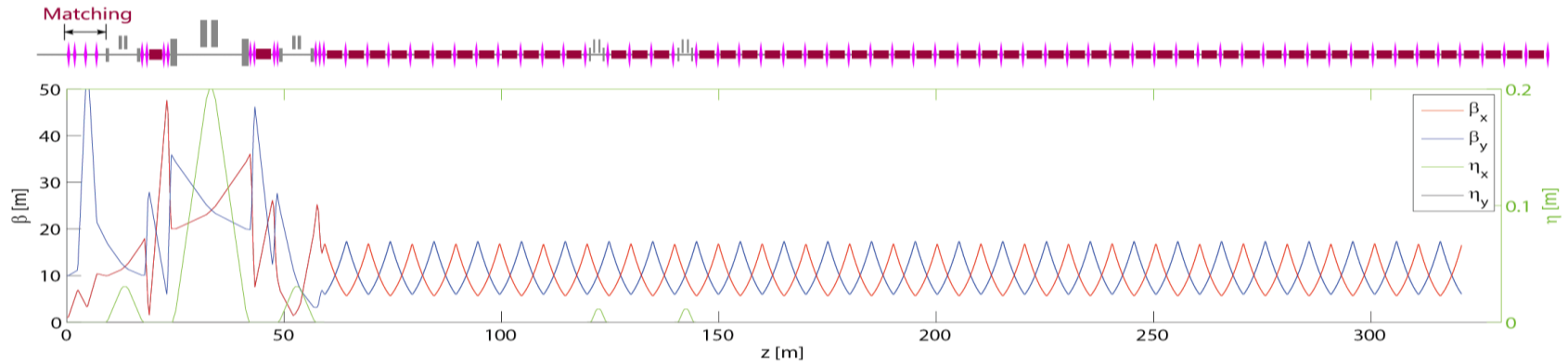

First stage (EEHG)
264nm → 6nm

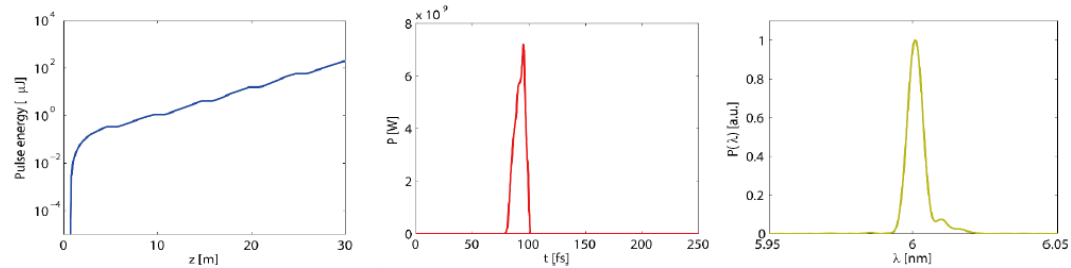

Second stage (HGHG)
6nm → 1nm

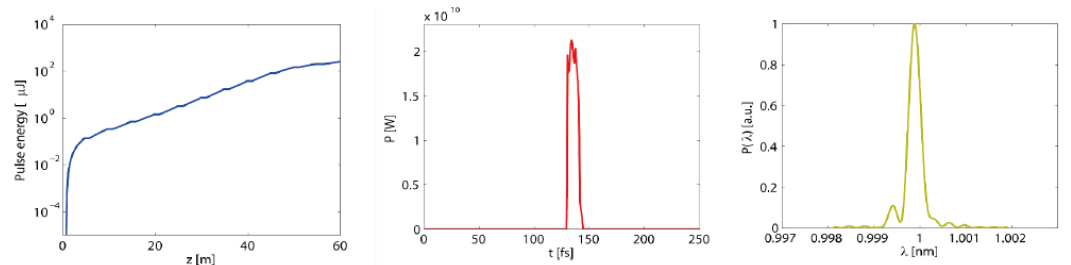

Photon energy: 1.24 keV
Bandwidth: 0.4eV
Pulse energy: 250μJ
Photon number: 1.2e12

EEHG-HGHG cascade@1nm, charge: 100pC

FEL-II baseline: EEHG-HGHG

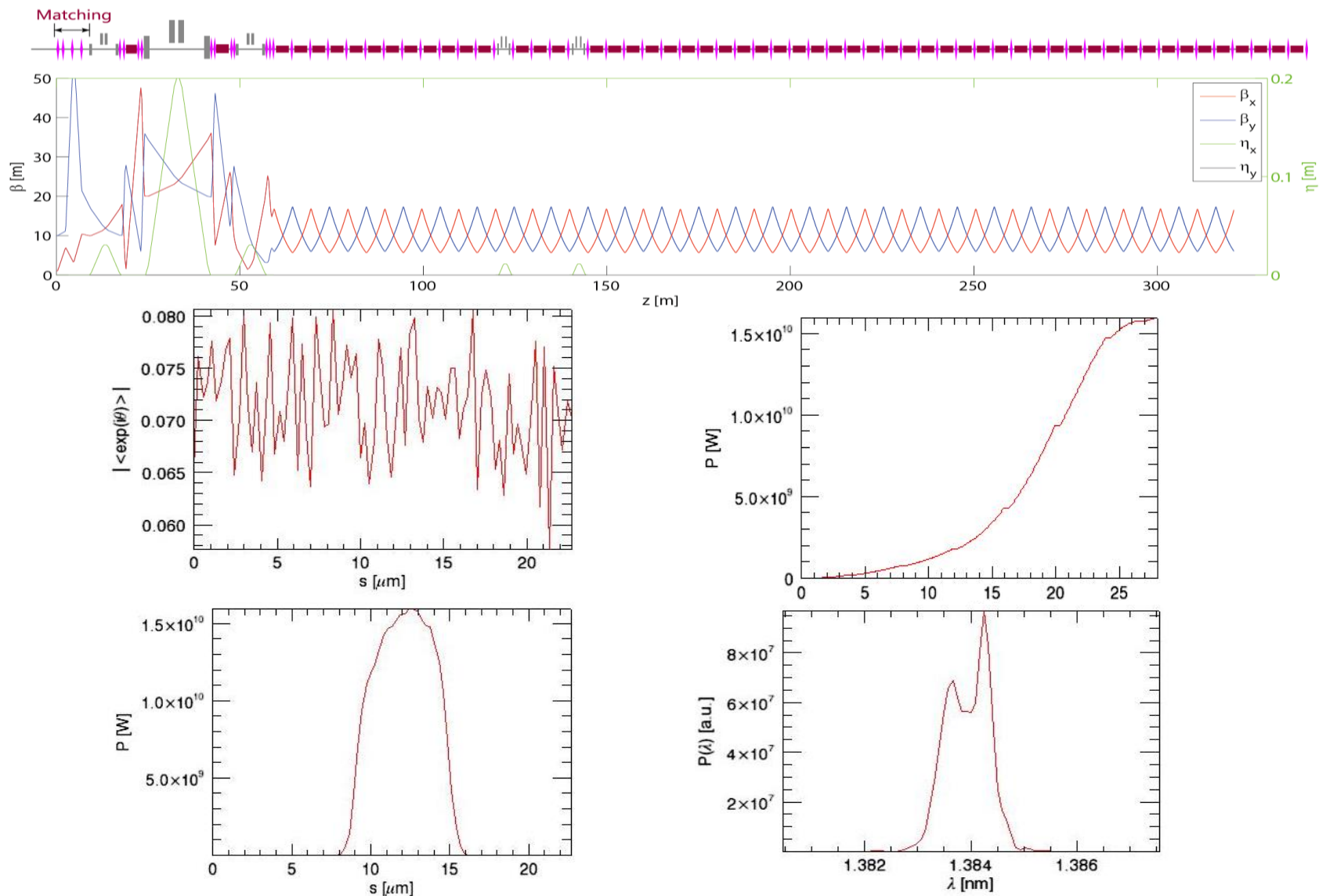

FEL-II baseline: EEHG-HGHG

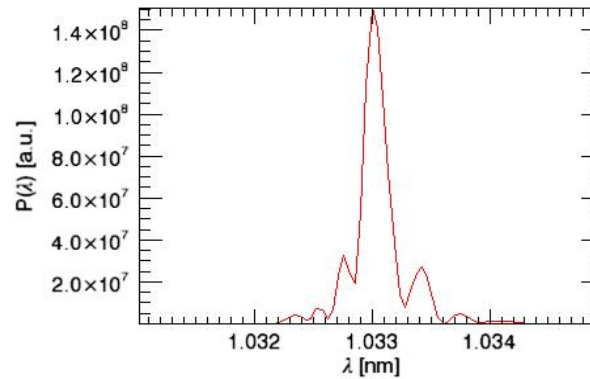
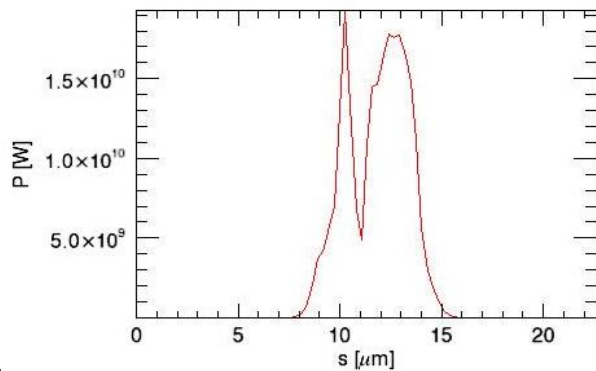
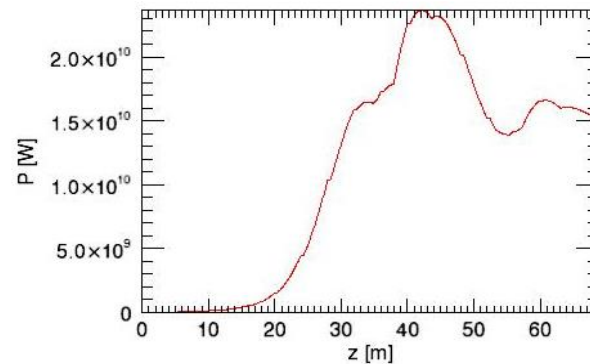
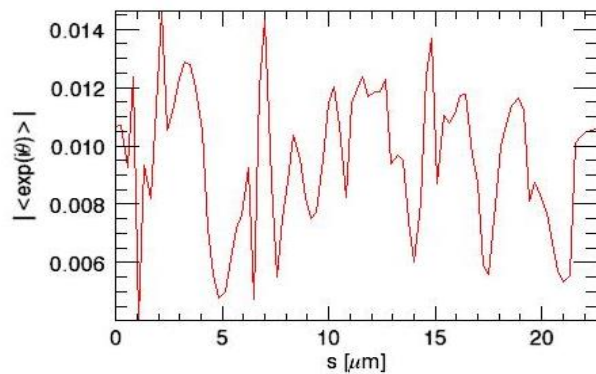
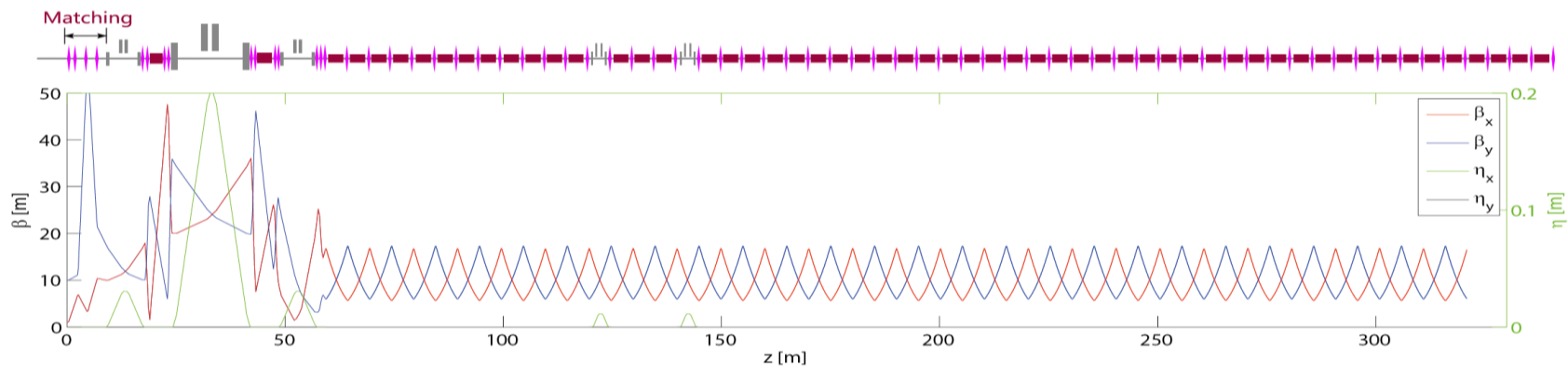

FEL-II baseline: EEHG-HGHG

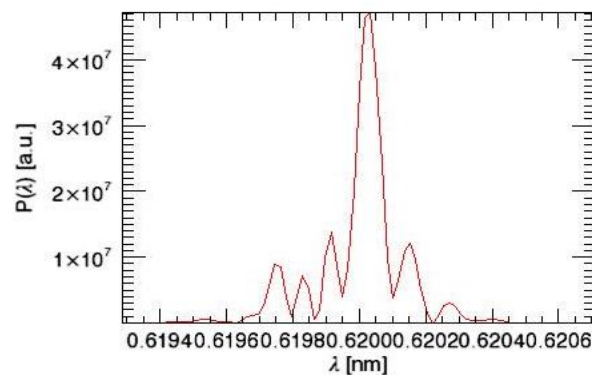
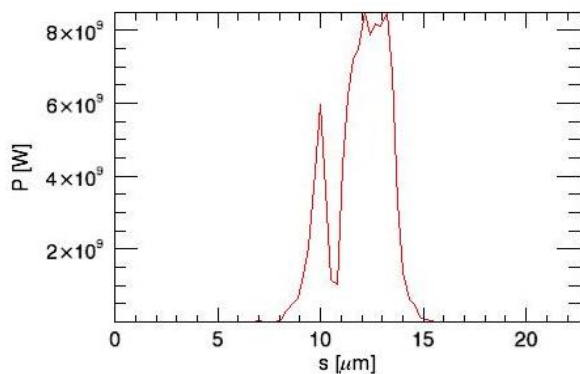
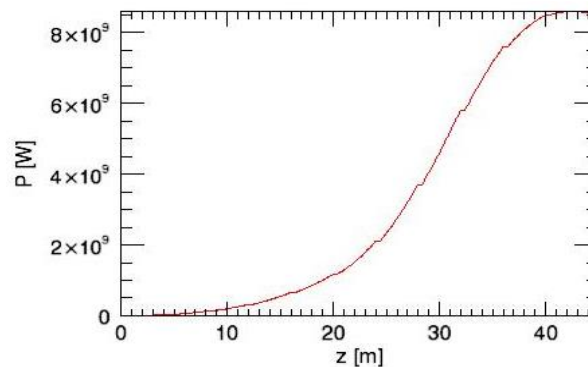
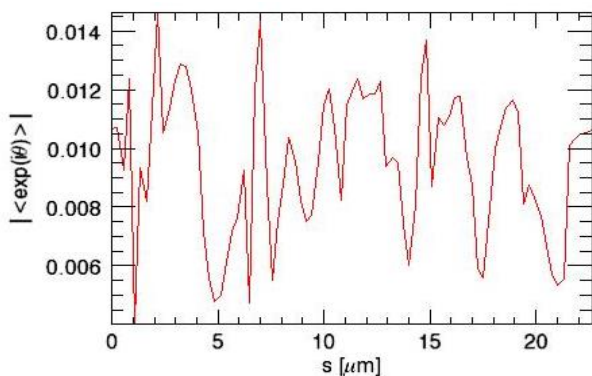
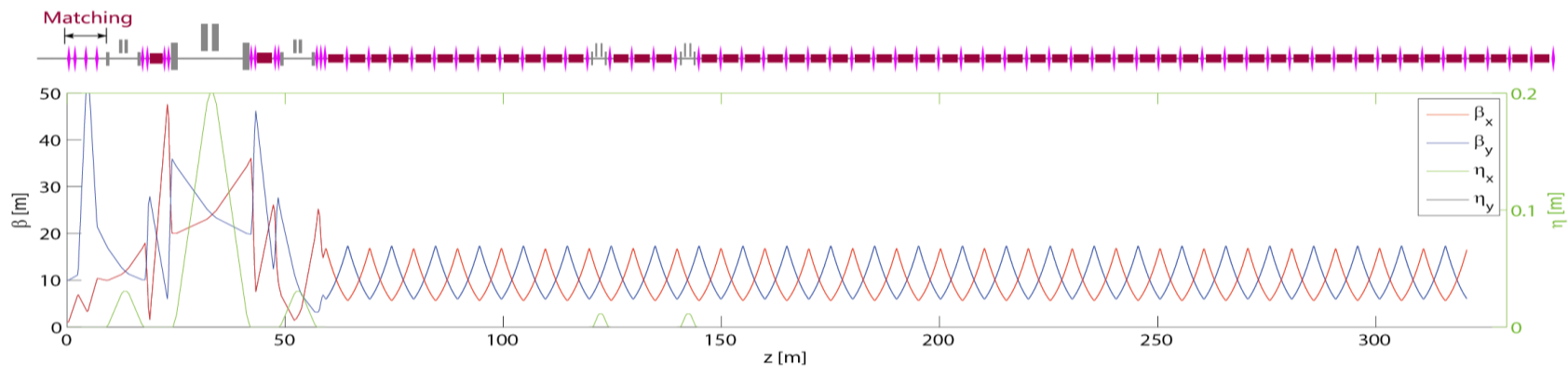

FEL-II self-seeding

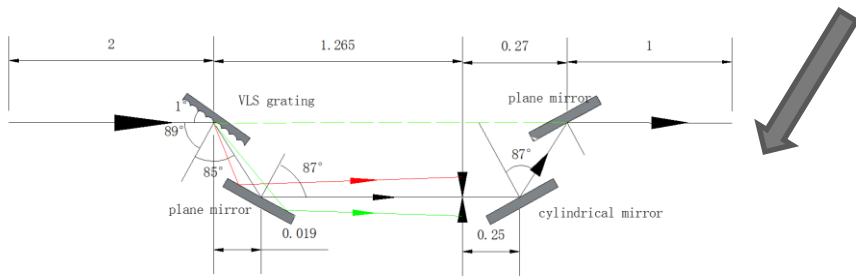
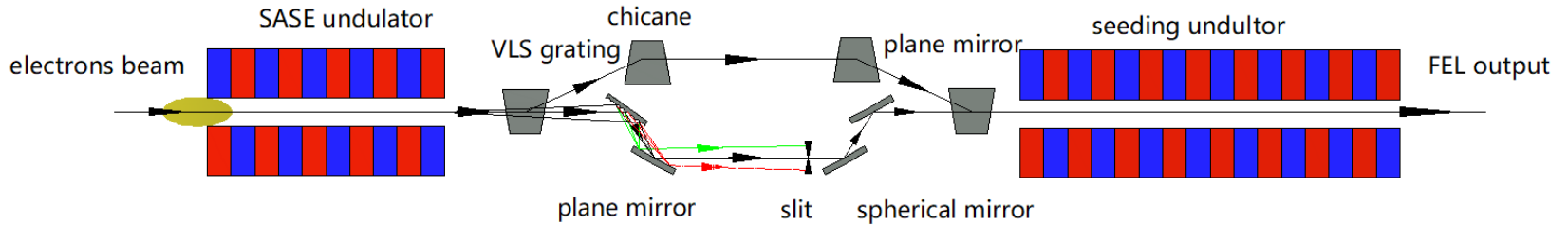

Grating-based monochromator

Incidence angle	89°
Diffraction angle	85°
$R_m(m)$	120
$R_{sag}(cm)$	38.5
$f_{obj}(m)$	2
$f_{imag}(m)$	1.4
delay(fs)	291-401
Resolution	10000
Transmission efficiency	~3%

Resolution > 10000

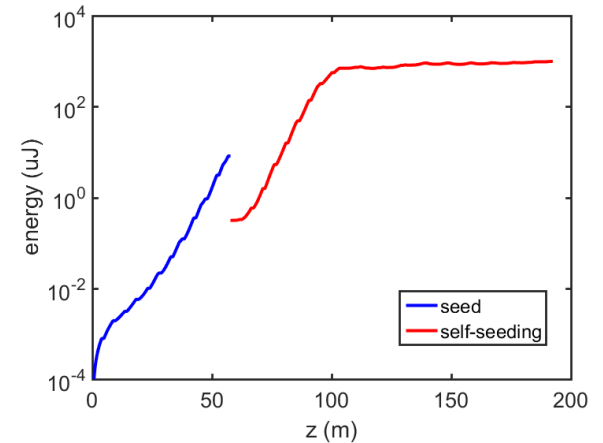
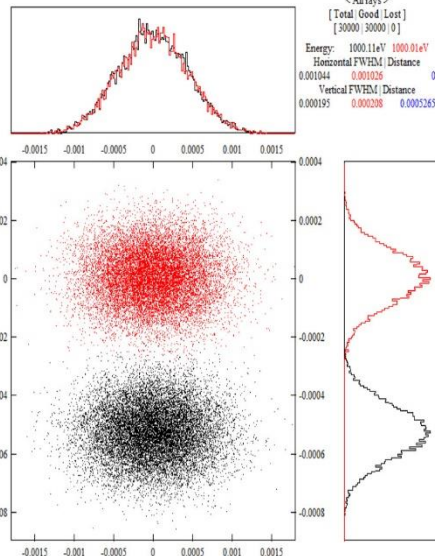

Self-seeding @ 1.24 keV, charge: 100 pC

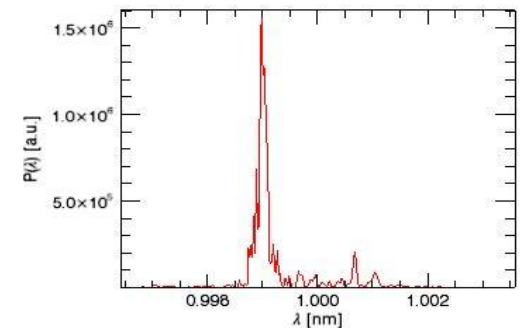

FEL-II self-seeding

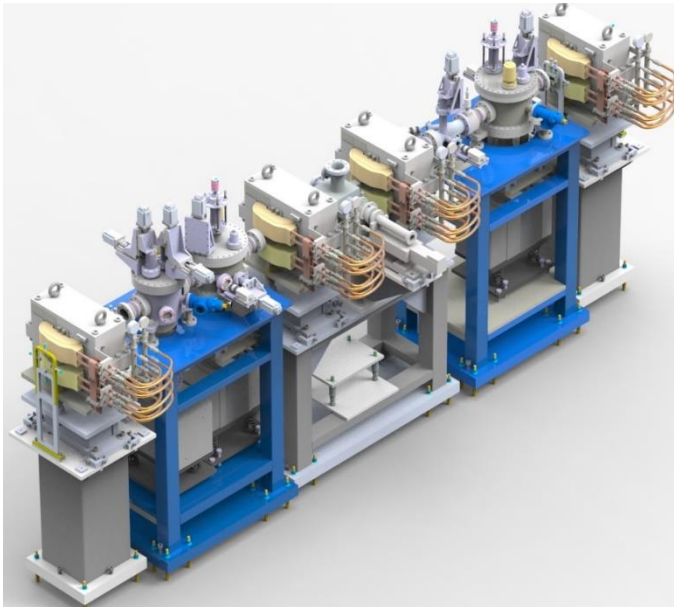
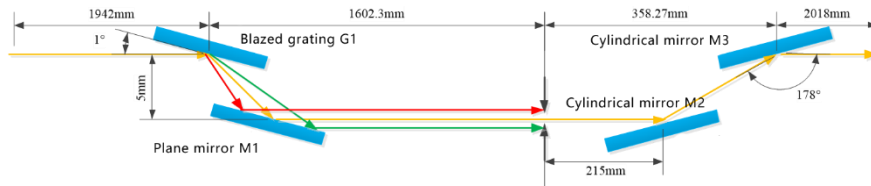
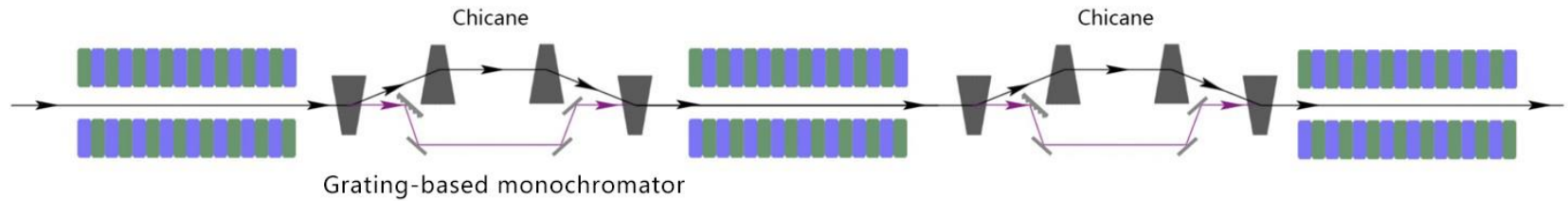

Requirements for the monochromator

	SHINE	SXFEL
Photon energy	0.4-1.5 keV	0.4-0.6 keV
Resolution	>5000@1keV	>5000@500eV
Efficiency	>1%@1keV	>0.5%@500eV
Total length	3.7m	

- Will be first tested at the SXFEL
- Two-stages self-seeding for SHINE FEL-II

FEL-II self-seeding

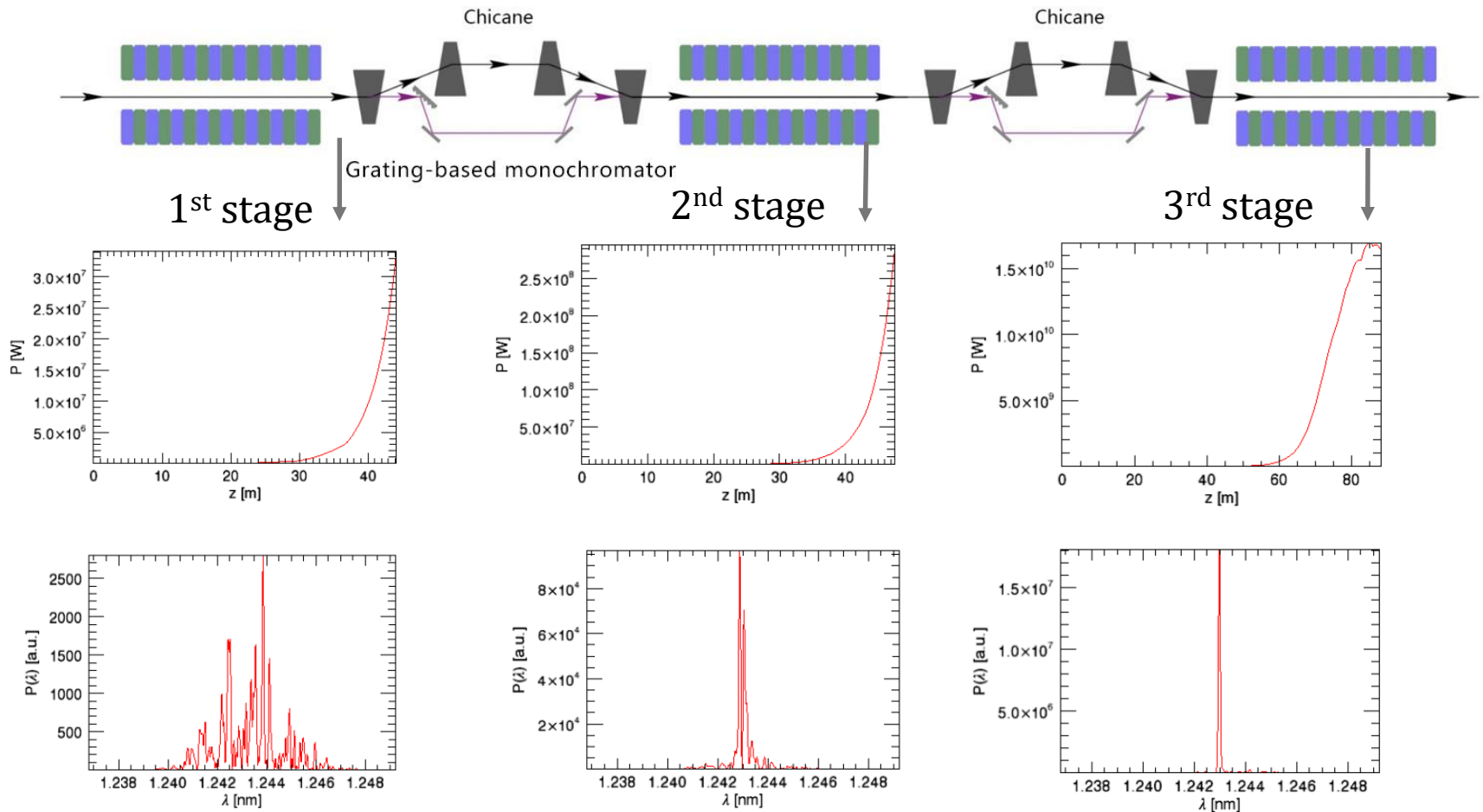

- Two-stage setup reduces the heat loading on the grating
- The final output bandwidth (FWHM) is about $1e-4$

FEL-II polarization control

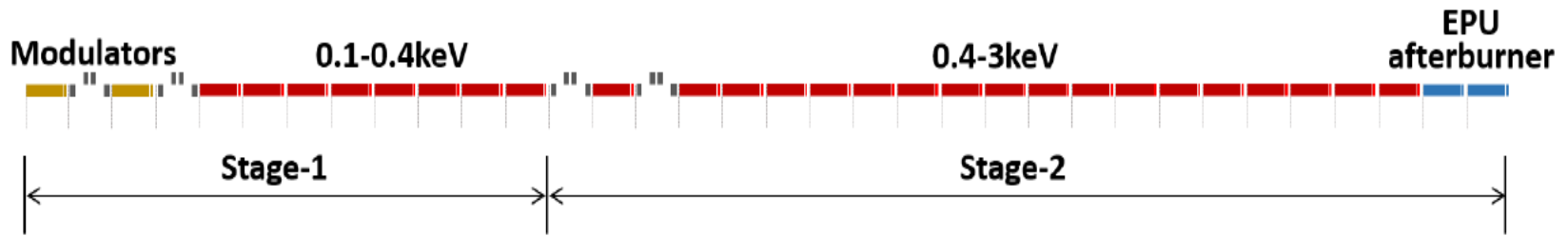

Left plot: the pulse energy growth curve; Right plot: the circular polarization evolution

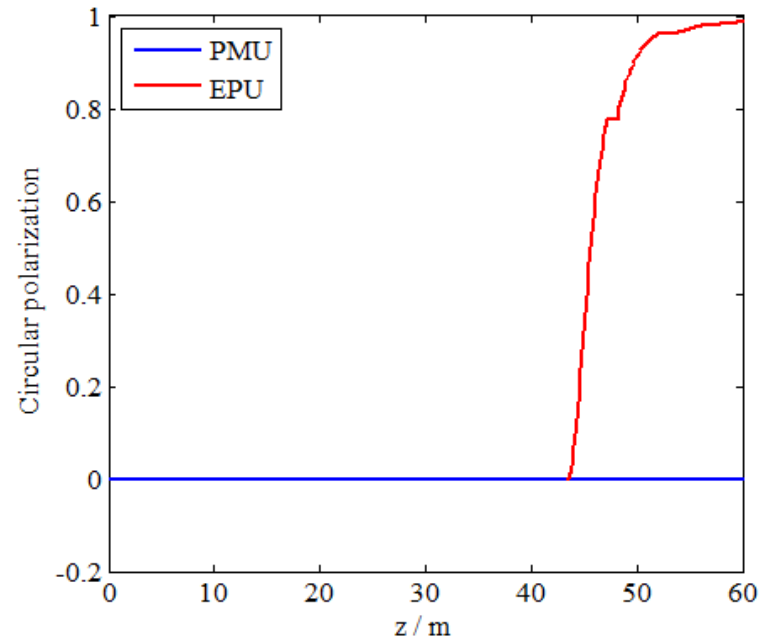
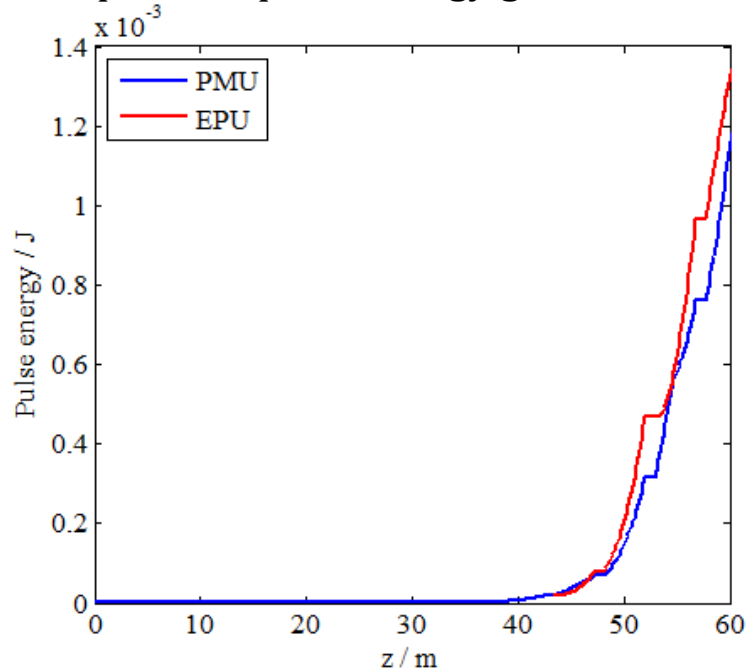

- Two EPU segments is efficient to generate circular polarized FEL pulse at 1.24 keV
- Polarization degree higher than 95%

FEL-III baseline: SASE (10-25 keV)

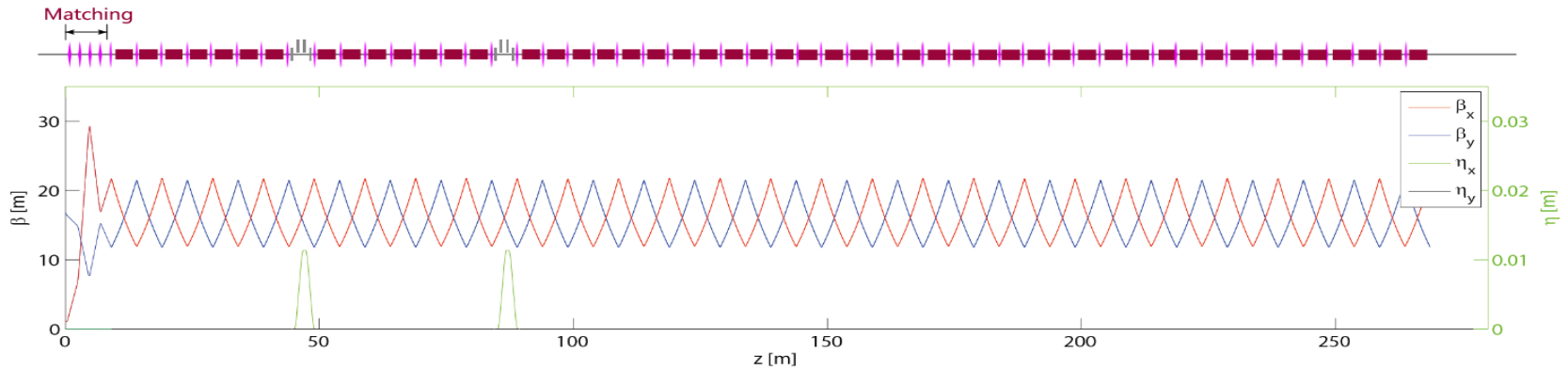

Undulators (40 segments)

Segment length 4 m

Period 16 mm

Chicanes for self-seeding (2)

Total length 3.6 m

Delay 0~250 fs

Max. offset 10 mm

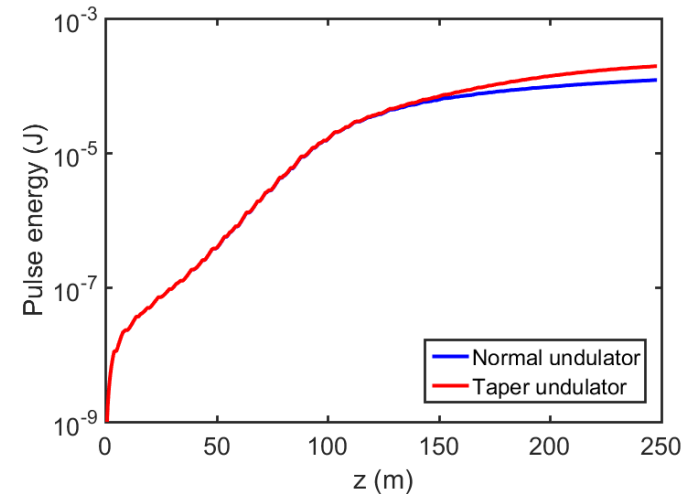

SASE@25 keV, charge: 100pC

FEL-III baseline: SASE (10-25 keV)

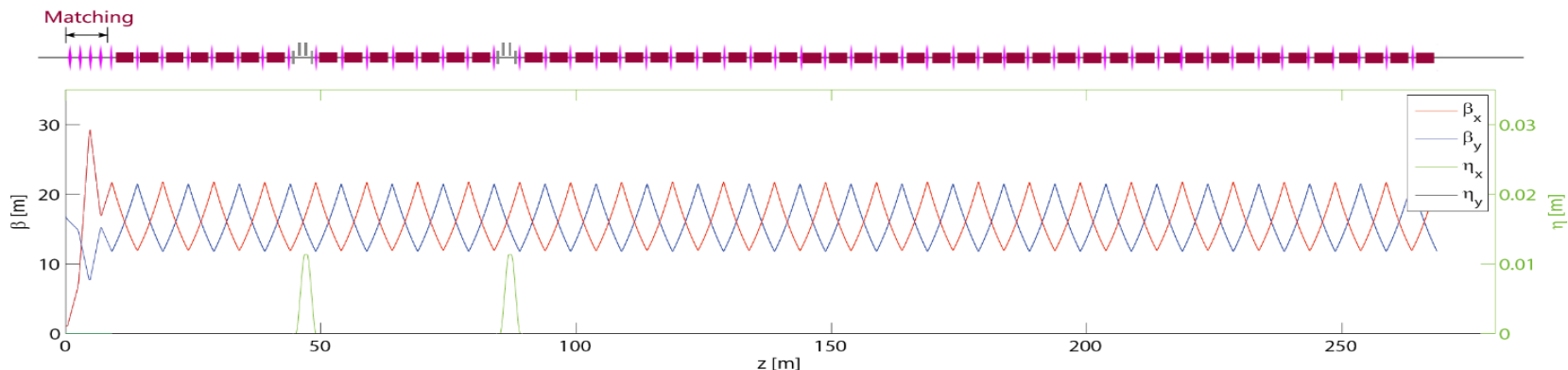

	Un-taper	Taper
Op. Mode	SASE	SASE
Photon energy	25keV	25keV
Peak power	2.5GW	7.0GW
Pulse energy	121 μ J	195 μ J
Pulse length	50fs	40fs
FEL bandwidth	0.08%	0.027%
Radiation size	60 μ m	90 μ m
Diffraction angle	4 μ rad	3.0 μ rad

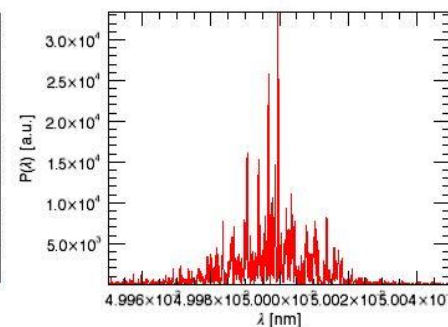
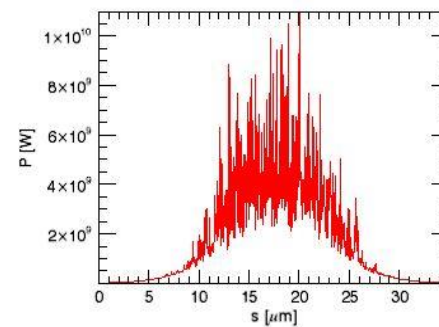
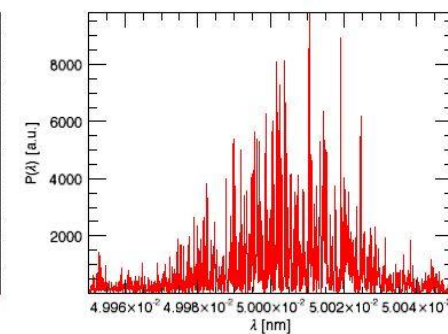
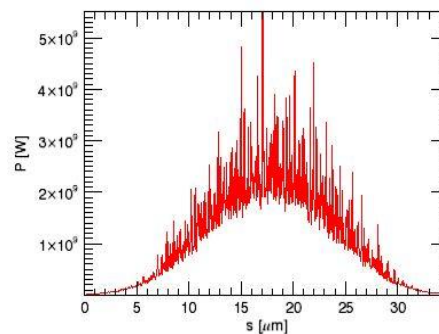

FEL-III self-seeding

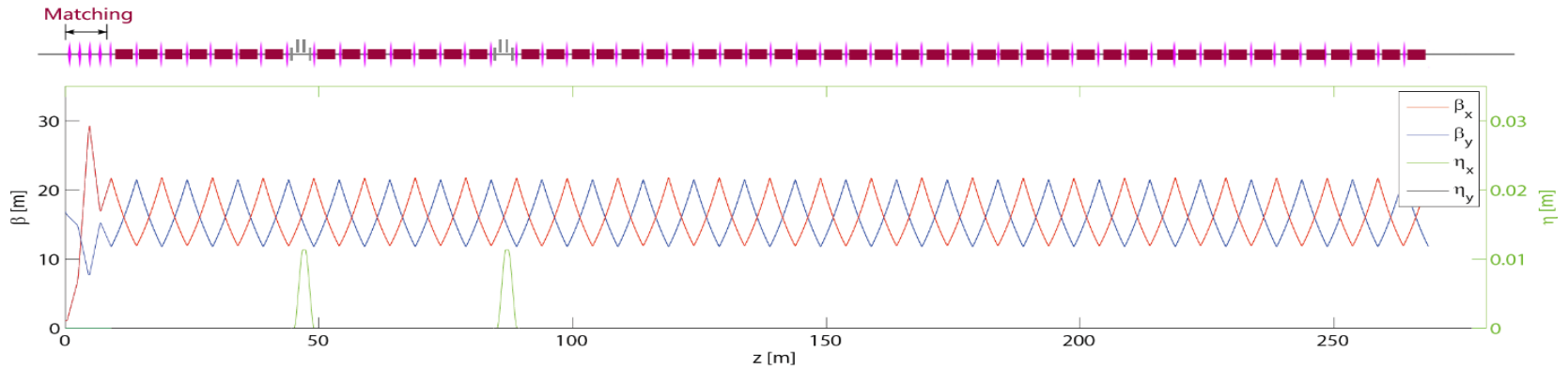

Self-seeding@25 keV, charge: 100pC

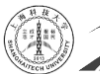
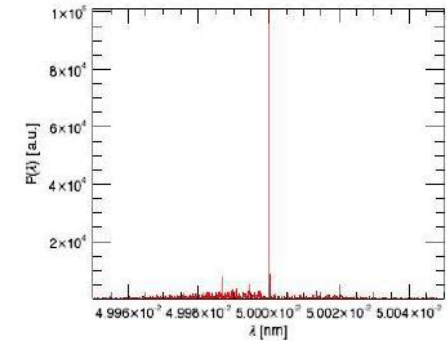
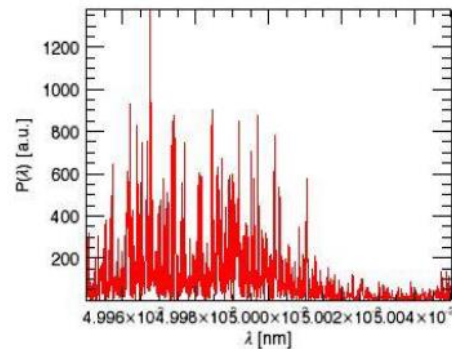
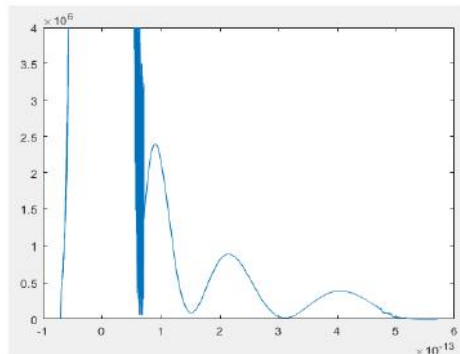
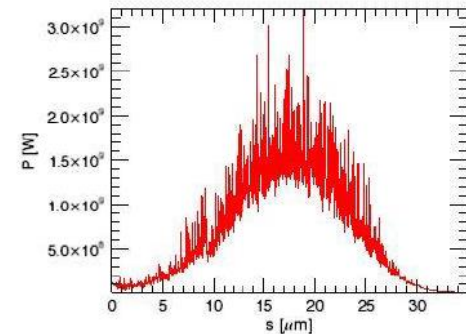
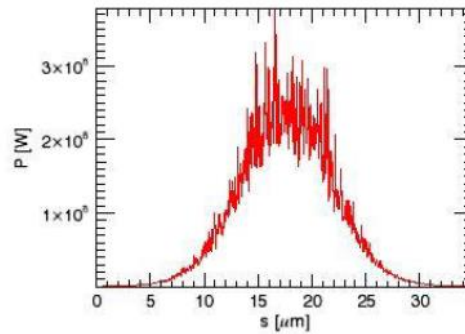
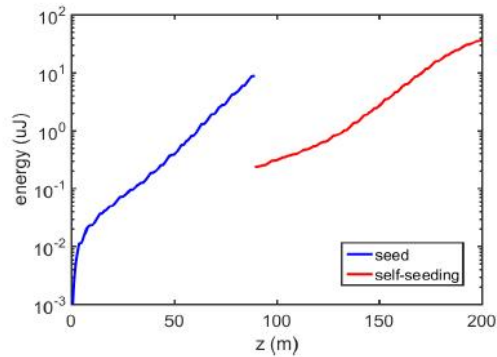

Preliminary S2E results

FEL-I: beam matching

ele2gen Twiss matching

Input:
 Input File: :
 Plot range of s [um]: -- Overlap: x&y [um]
 Slice:
 slicID [um]:

Energy [MeV]:	Current [A]:	Emittance [um]:		Energy spread:
8034.05	1654.17	0.187983	0.1875	0.000132047

Goal:

Beta_x [m]:	Beta_y [m]:	Alpha_x:	Alpha_y:
19.8679	3.7184	-2.3168	0.44638

Output:
 Output File:

$\sigma_{x,y}$ [μm]

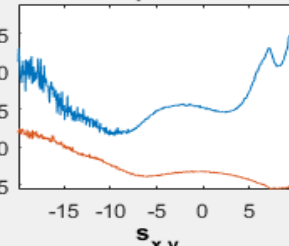

$s_{x,y}$

$\alpha_{x,y}$

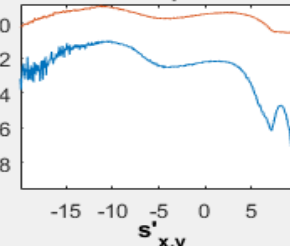

$s'_{x,y}$

$\sigma_{x,y}$

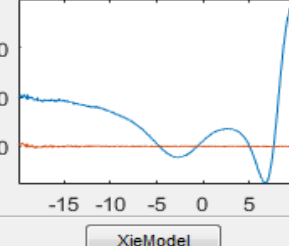

$\alpha_{x,y}$

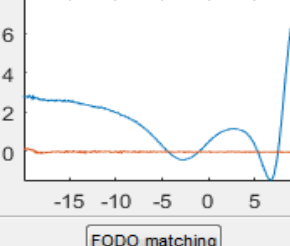

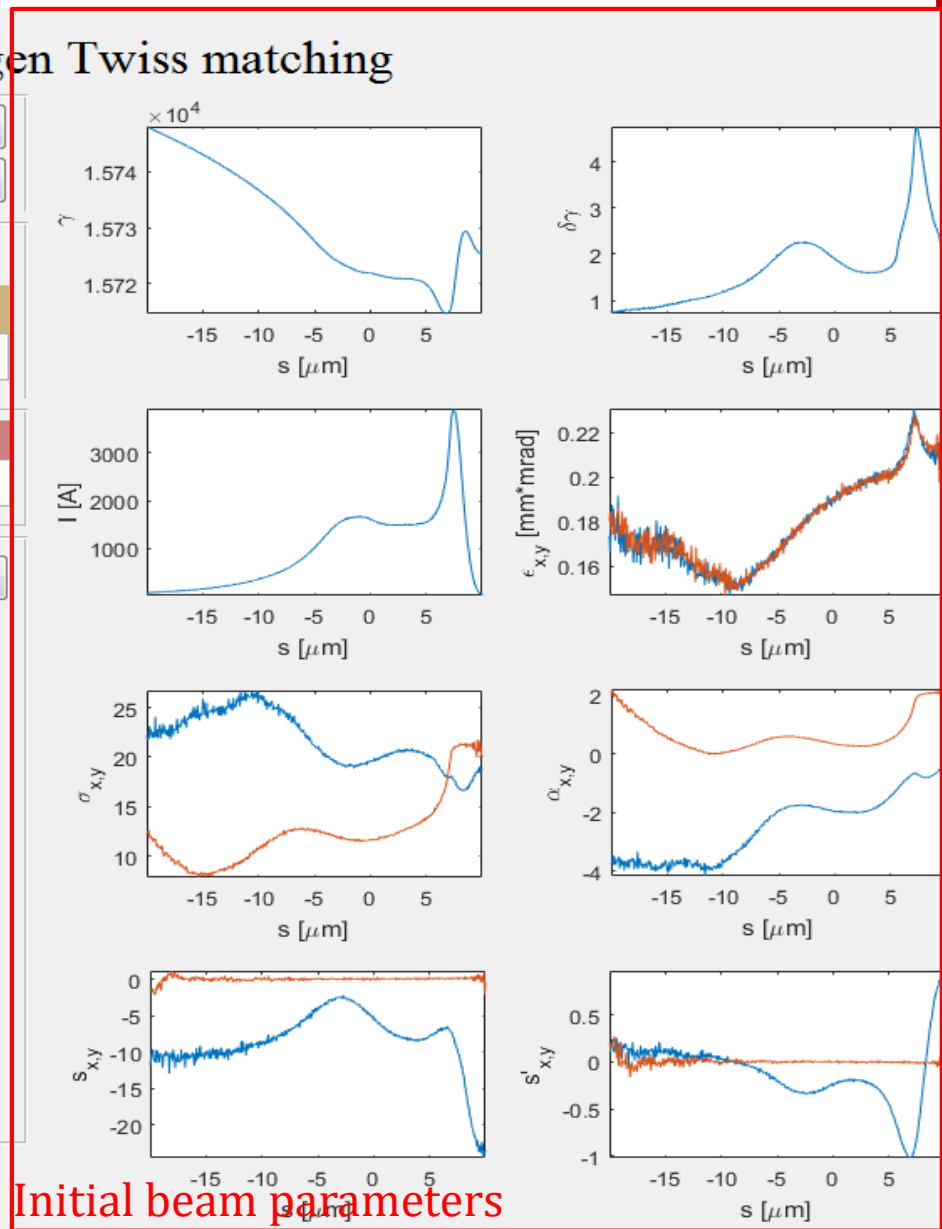

Target beam parameters

Initial beam parameters

FEL-I: SASE@12.4keV

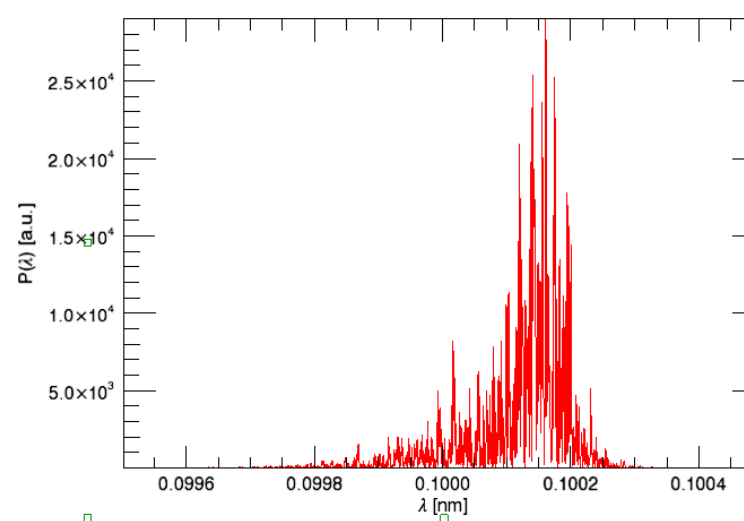
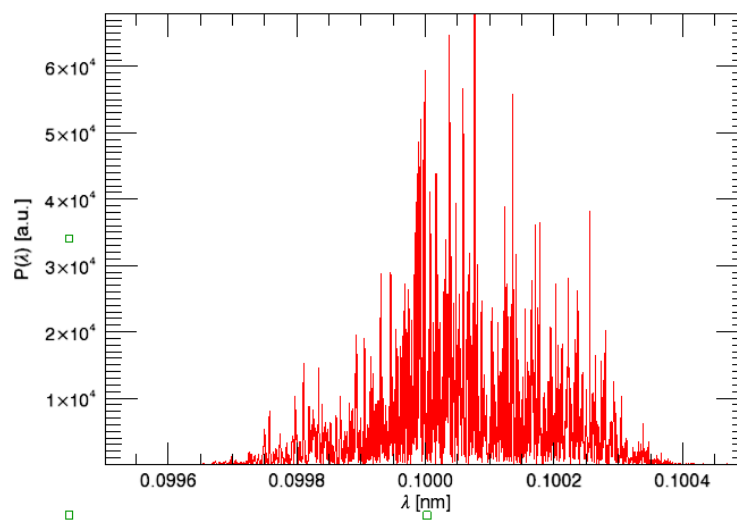
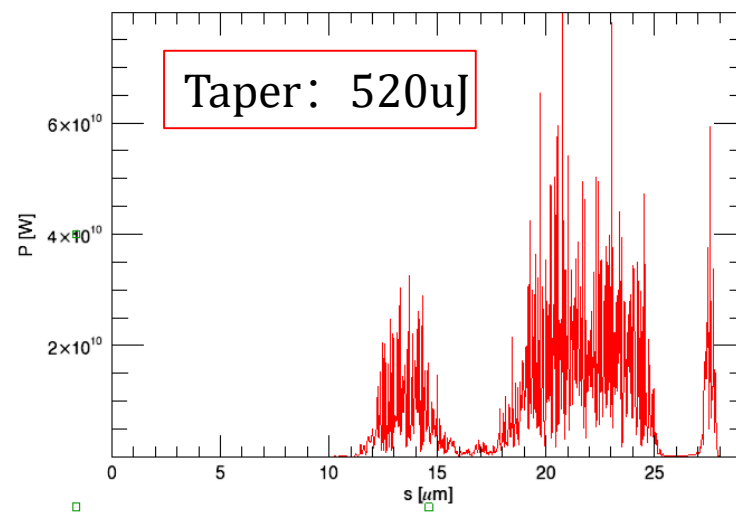
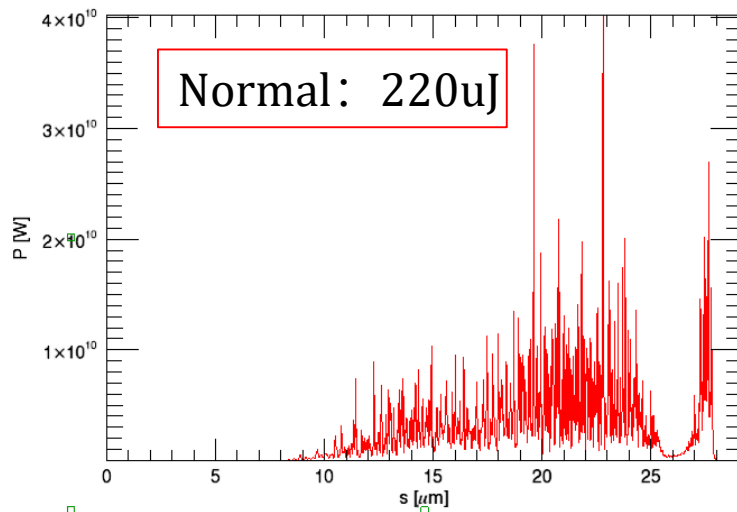

FEL-I: single stage HXSS

◆ Undulator segmentation: 8+26

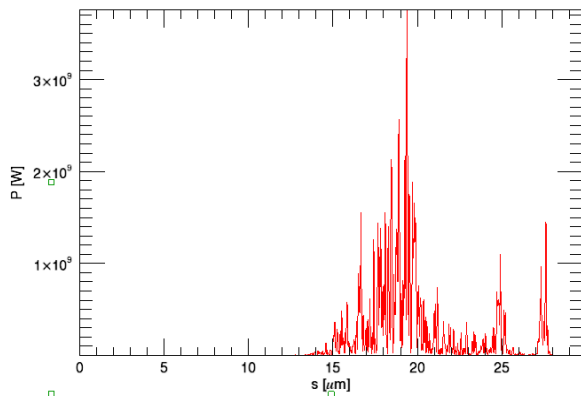

Before mono: 14uJ

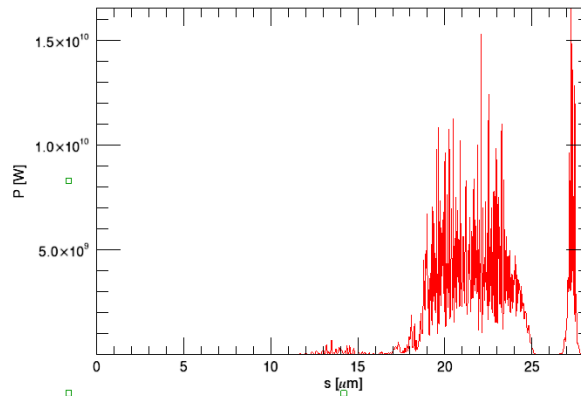

Saturation: 140uJ

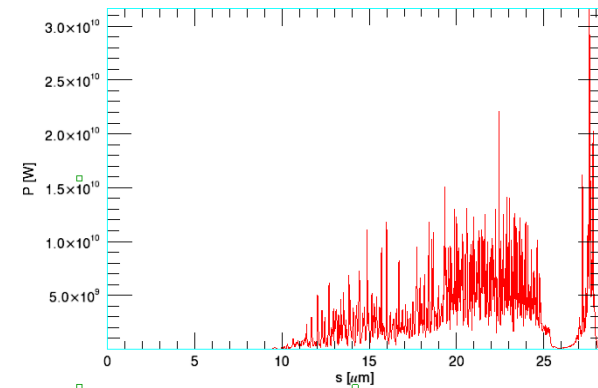

Output: 240uJ

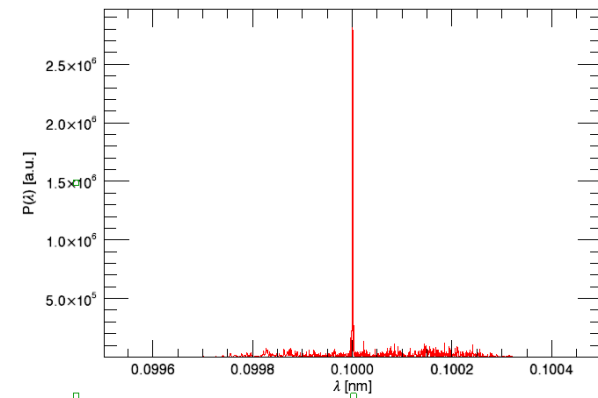
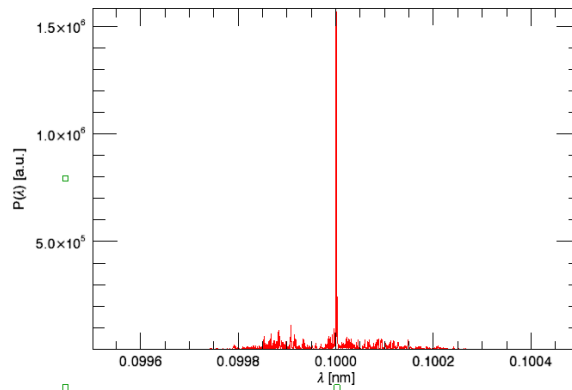
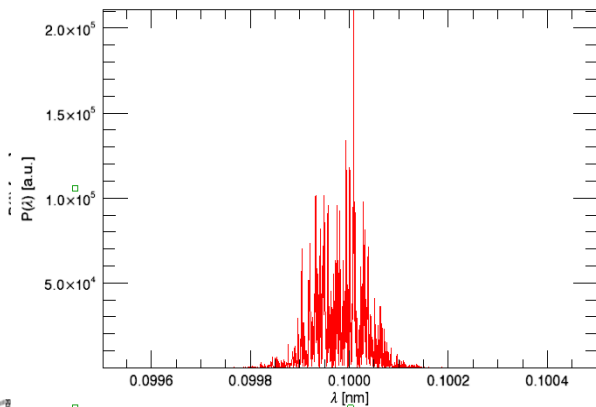

FEL-II: input beam

Current and Gamma

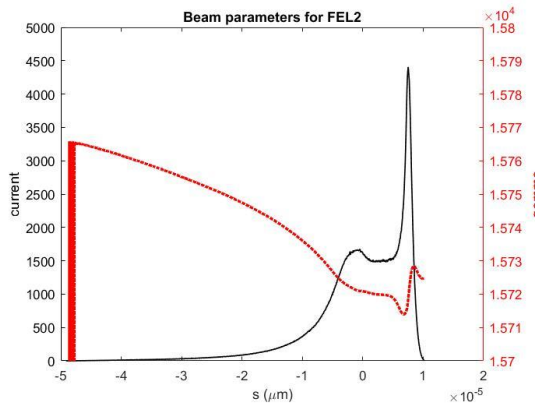

Current and energy spread

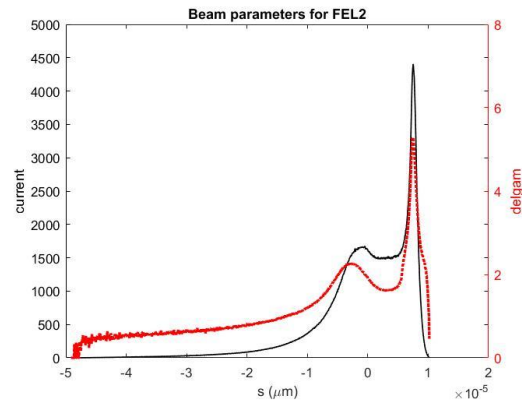

Normalized emittance x/y

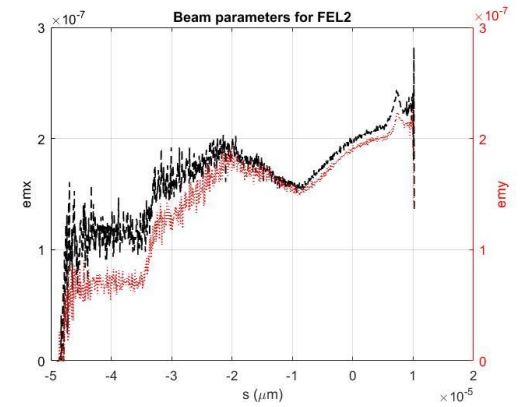

Center of slices x/px

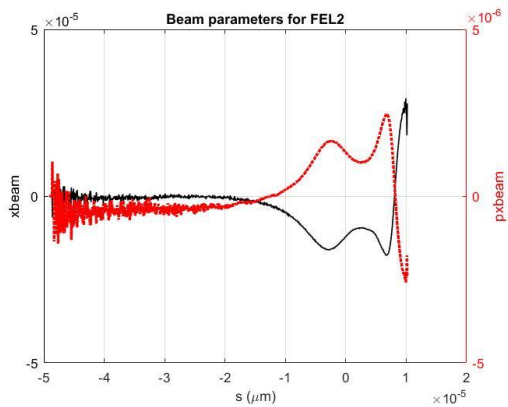

Center of slices y/py

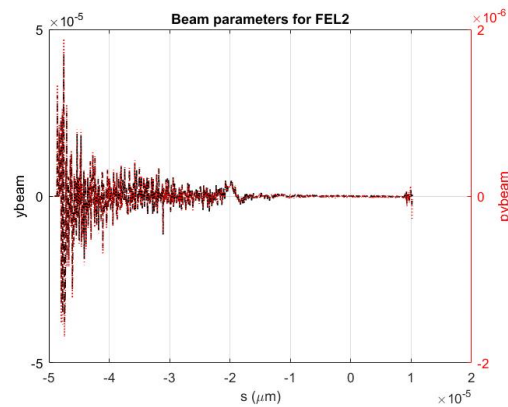

Rxbeam/Rybeam

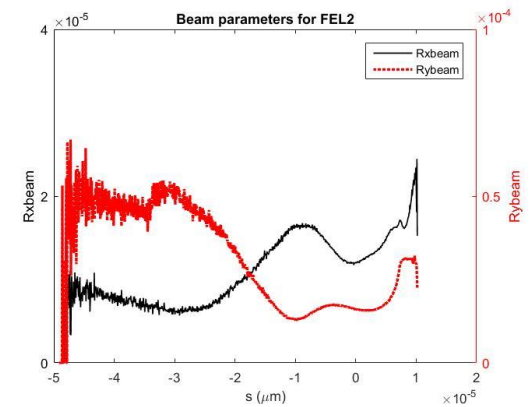

FEL-II: SASE @ 12.4keV

Power @ 4m SASE

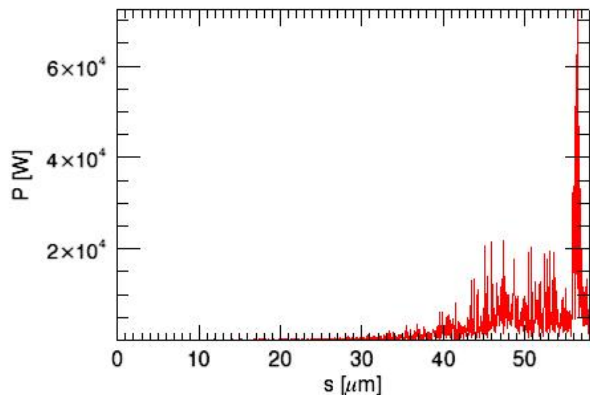

Power @ 40m SASE

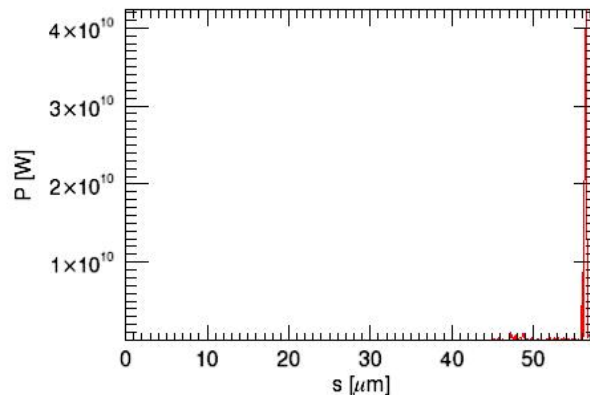

Power @ 60m SASE

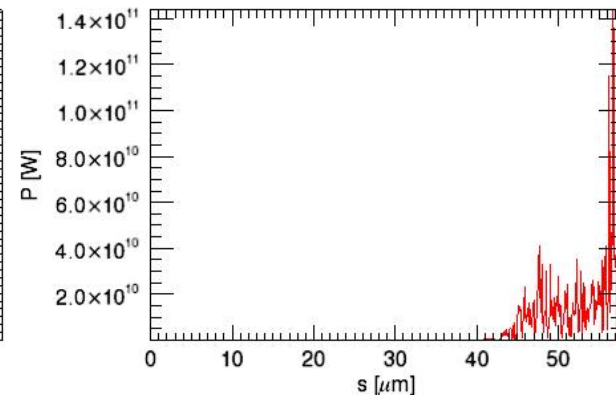

Spectrum @ 4m SASE

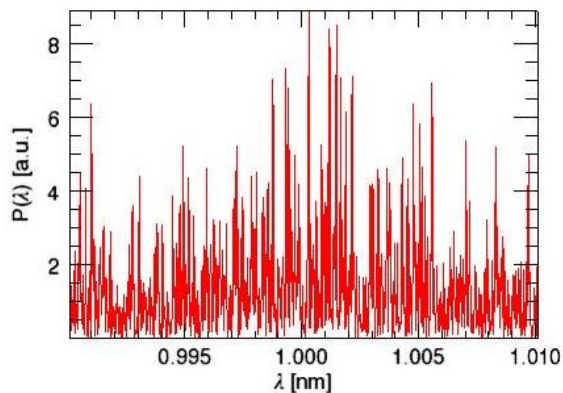

Spectrum @ 40m SASE

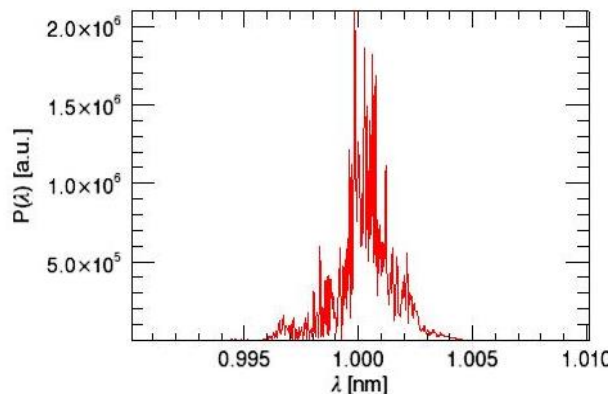

Spectrum @ 60m SASE

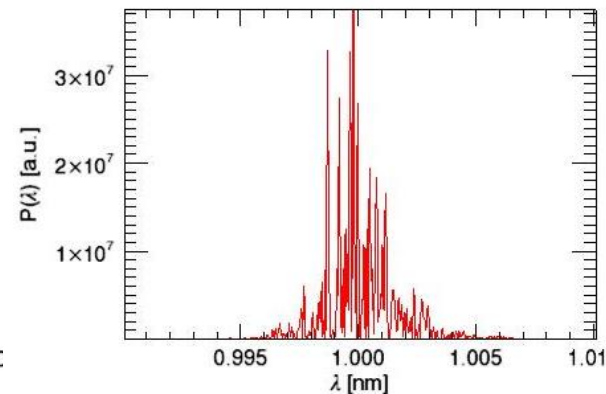

FEL-II: first stage EEHG-54

Echo bunching @ first-stage

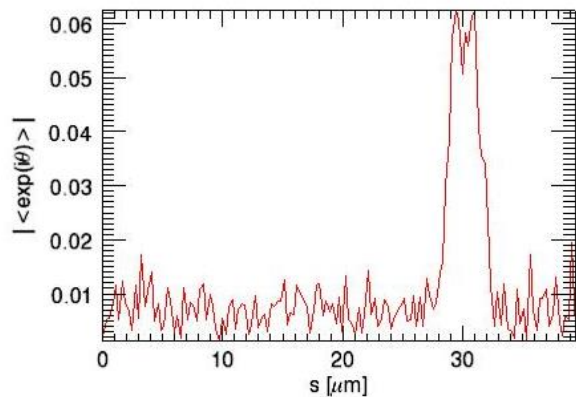

Total spectrum @ first-stage 12m

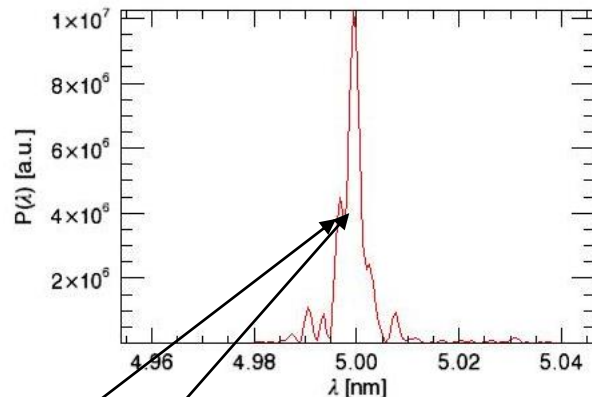

Pulse @ first-stage 16m

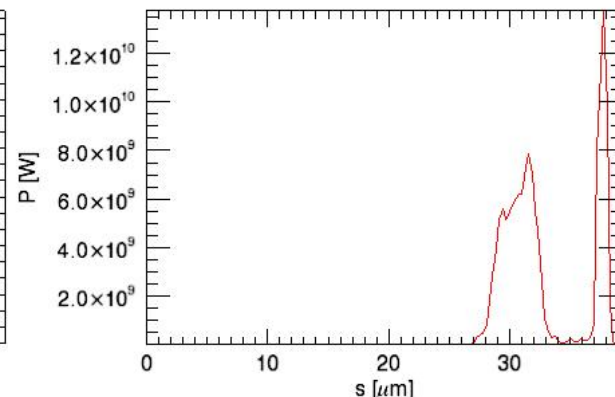

Pulse @ first-stage 12m

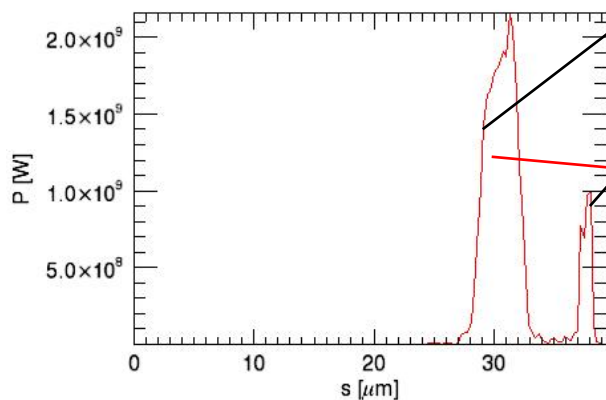

bunching spectrum @ first-stage 12m

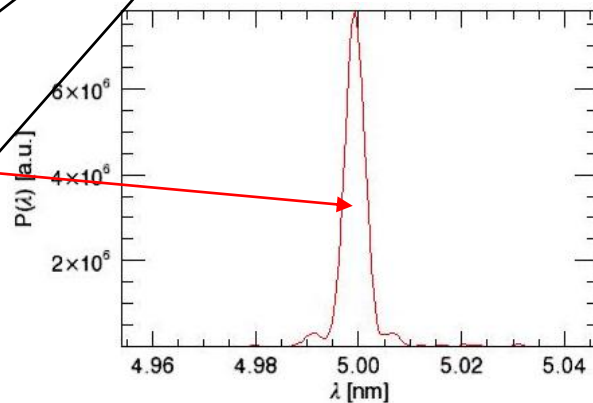

Total spectrum @ first-stage 16m

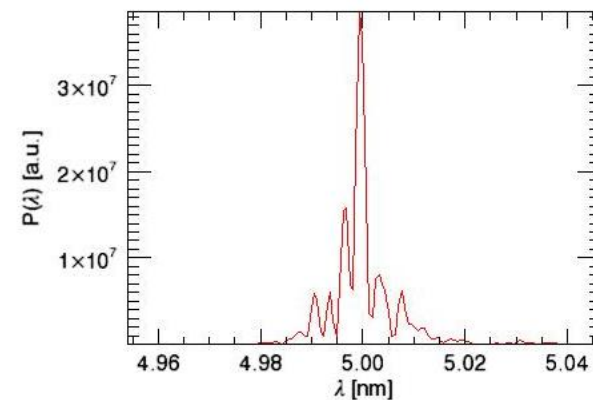

FEL-II: second stage HGHG-5

Power @ 4m Seeded

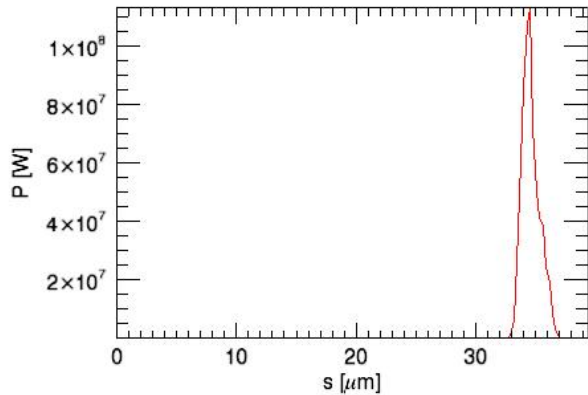

Power @ 20m Seeded

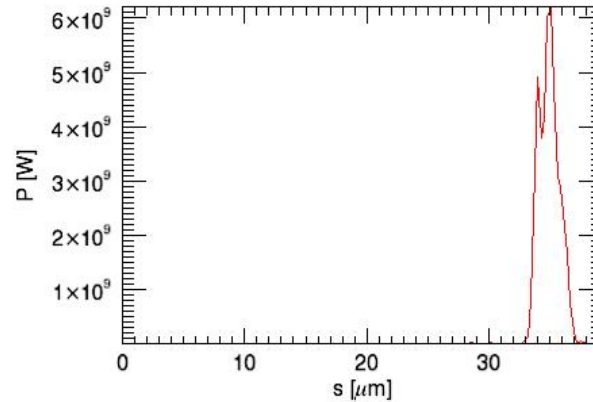

Power @ 28m Seeded

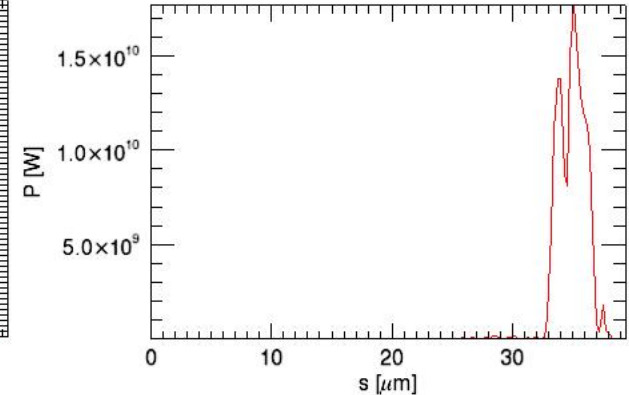

Spectrum @ 4m Seeded

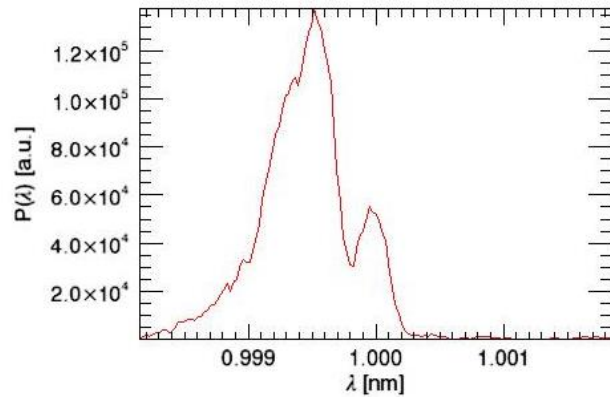

Spectrum @ 20m Seeded

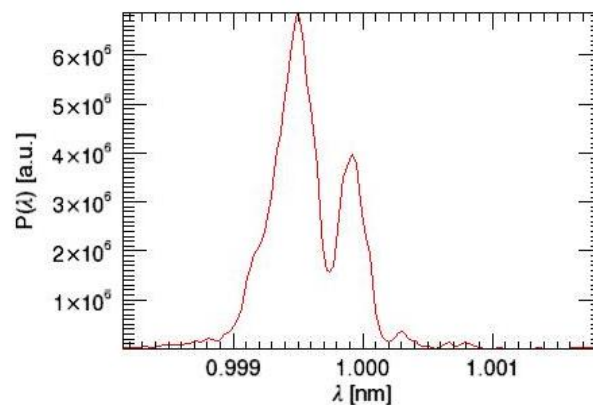

Spectrum @ 28m Seeded

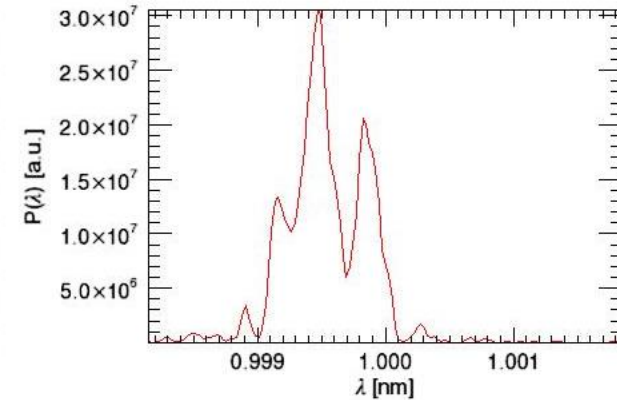

FEL3: wake effect

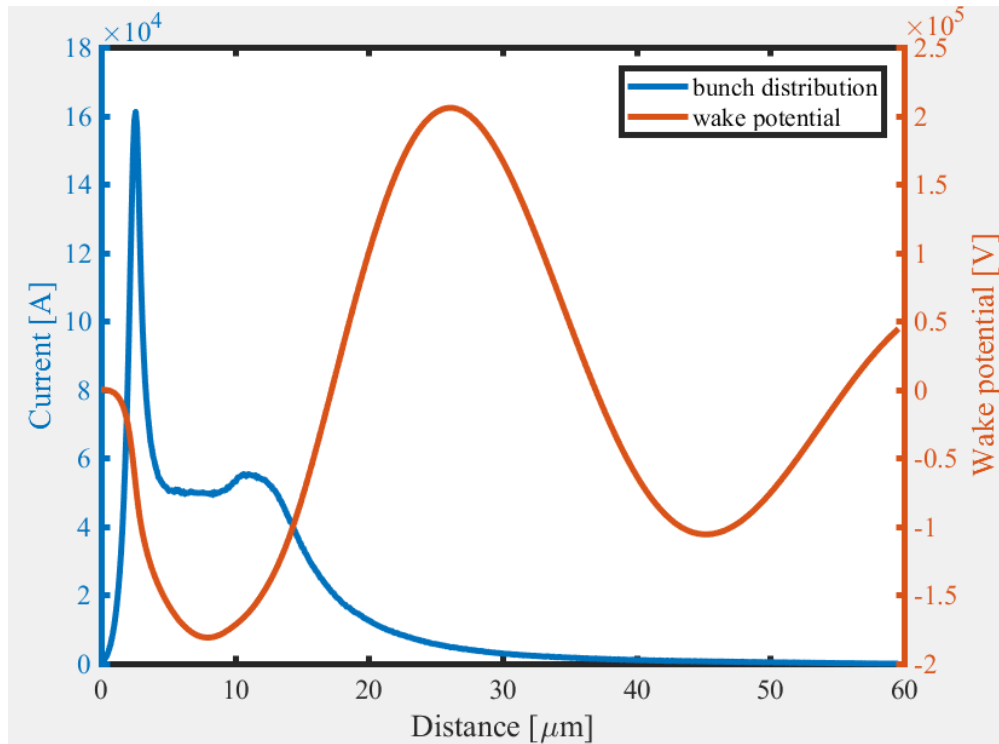

- ❑ Current spike at bunch head drives a significant energy loss in the undulator
- ❑ Wake issue is most serious in FEL-III, due to the large bending angle (3.6°) in the switch yard and the smallest undulator gap (4mm)

FEL-III: SASE @15keV without taper

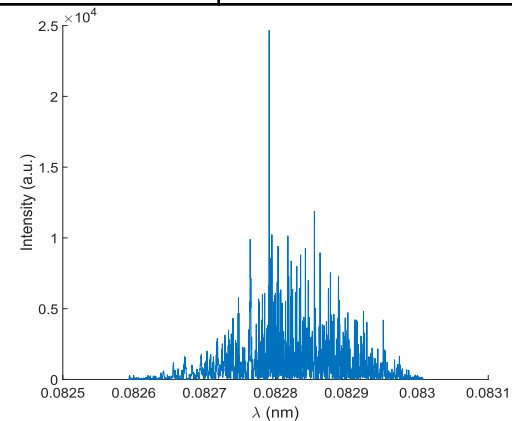
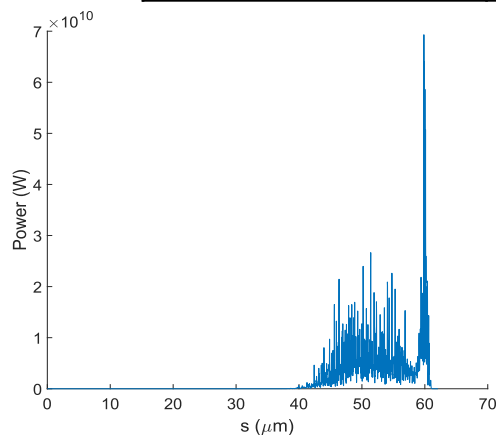
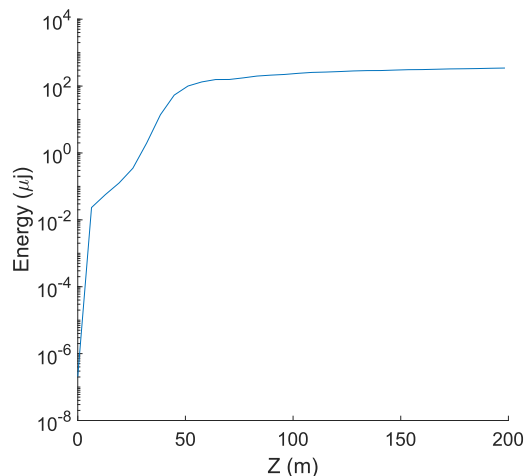

Pulse energy	346.5 μJ	Without wake
Pulse energy	59 μJ	With wake

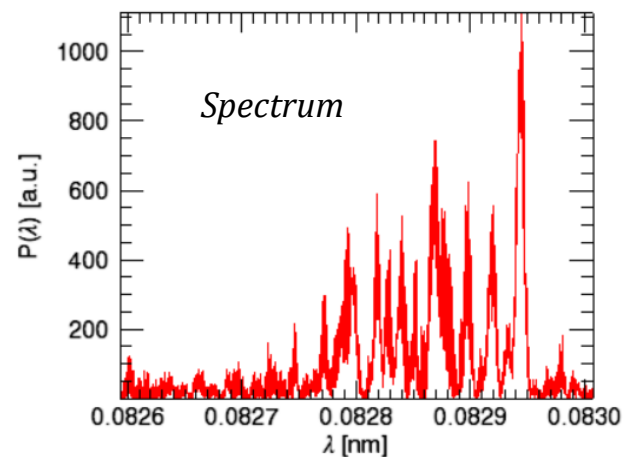
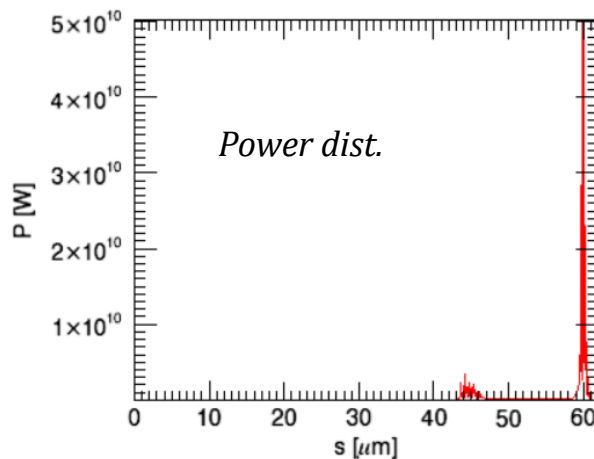
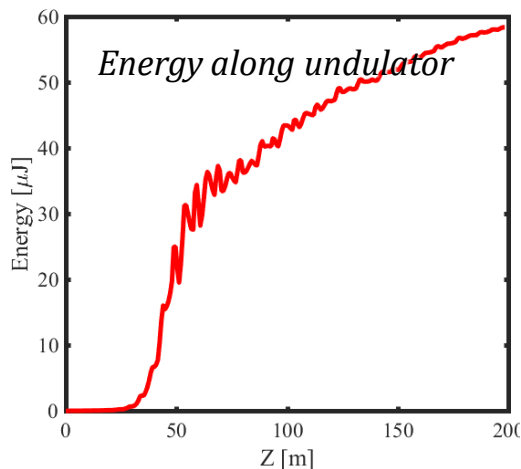

FEL-III: SASE @15keV with taper

Pulse energy

560 μJ

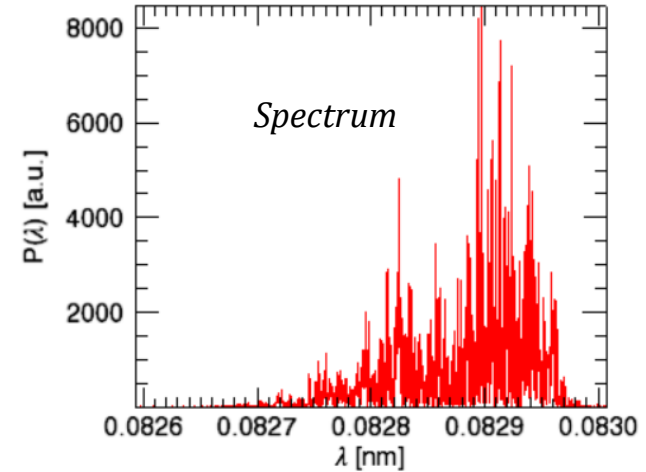
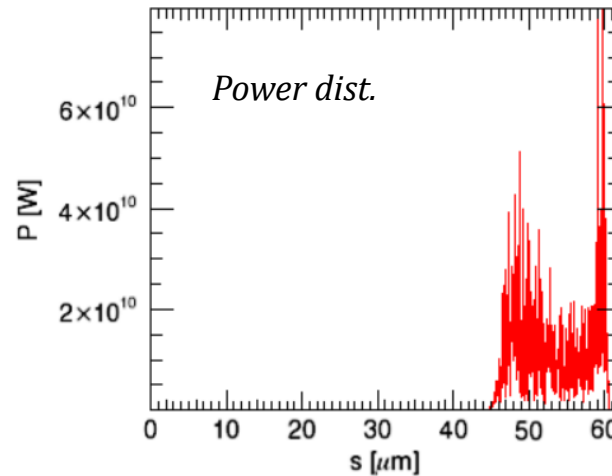
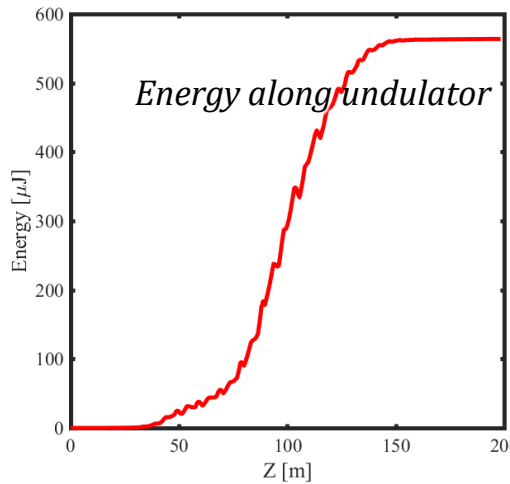

With quadratic taper, SASE power can be recovered to hundreds μJ

FEL-III: SS@15keV with taper, no wake

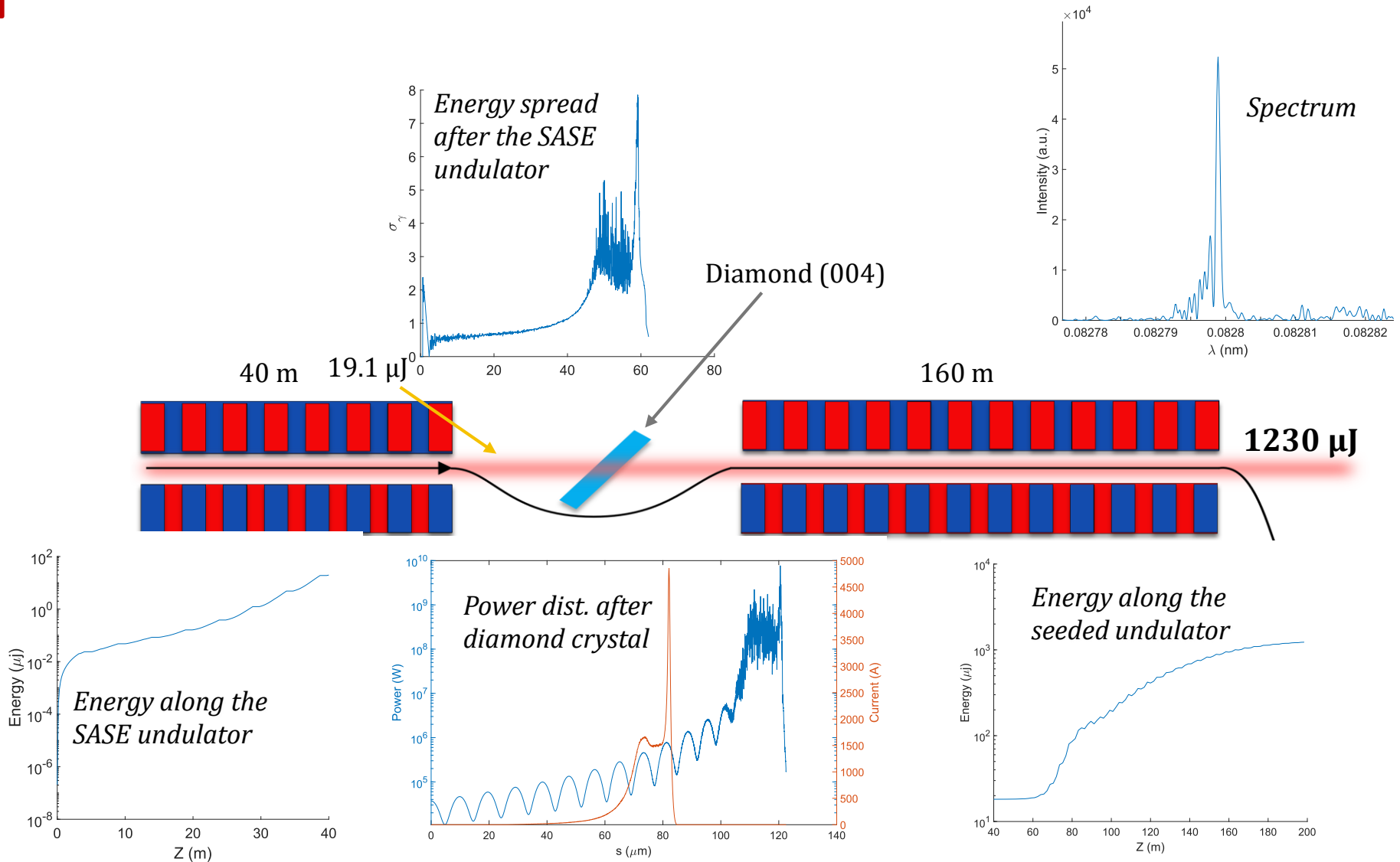

FEL-III: SS@15keV with taper, with wake

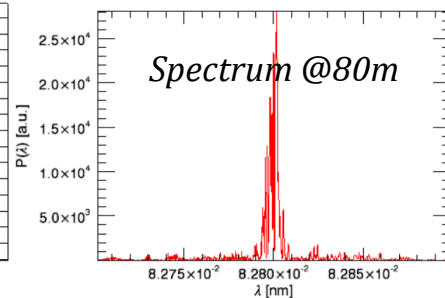
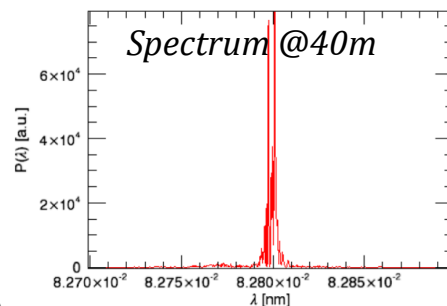
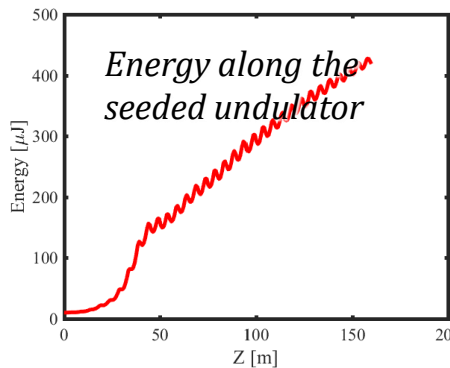
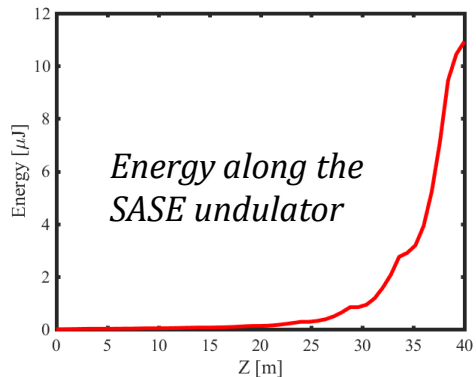
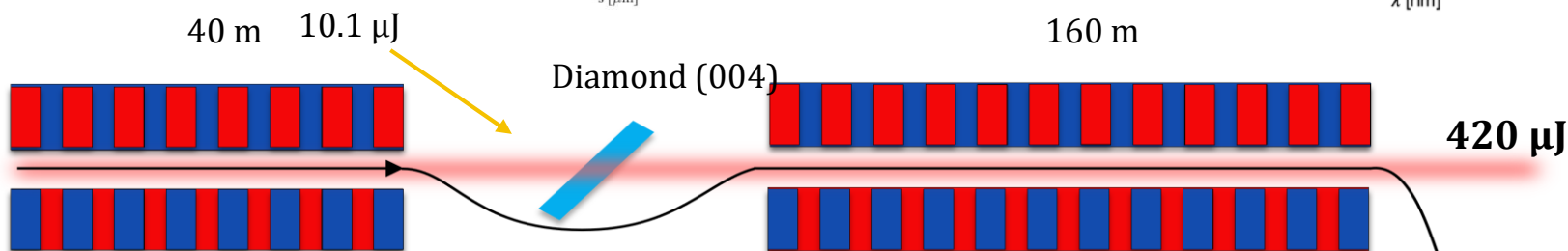
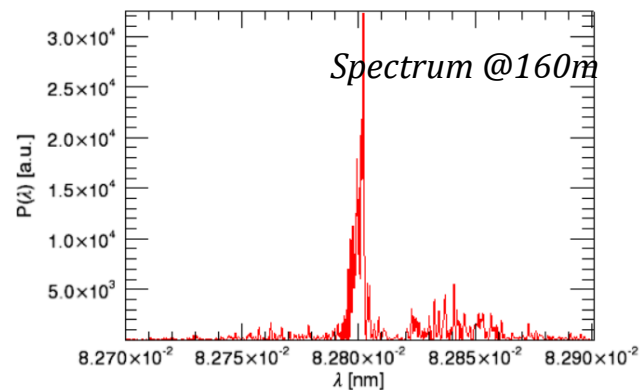
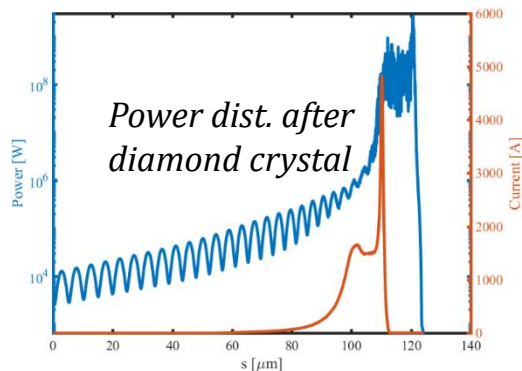

Summary & Outlook

- ◆ Layout of SHINE (including injector, main accelerator, beam switchyard, undulator lines) is almost fixed
- ◆ Various FEL operation modes have been designed for three undulator lines, while external seeding and self-seeding will be utilized to generate fully coherent X-ray FELs
- ◆ Parameter scanning and preliminary start-to-end simulations have been performed to verify the FEL performance
- ◆ Still a lot of work to do and a long way to run...



Thanks for your attention!