

WIR SCHAFFEN WISSEN – HEUTE FÜR MORGEN



Thomas Schmidt :: Paul Scherrer Institut

# Practical Experience with Short Period Undulator Systems

Workshop on “Shaping the future of the European XFEL:  
options for the SASE4/5 tunnels”

December 6/7 2018

short period undulator:

hybrid ppm undulators:

magnet materials

in-vacuum room temperature

-> SwissFEL Aramis U15

design, optimization, operation

in-vacuum cryogenic

sc undulators:

NbTi

Nb<sub>3</sub>Sn

HTS



Efim Gluskins talk

# Magnet material improvements

Br: strength      H<sub>cj</sub>: stability, i.e. radiation hardness

- at room temperature with high coercivity of H<sub>cj</sub> = 2400kA/m

			Dy diffusion	Tb diffusion
NdFeB	Br =	1.15T	1.25/1.26T	1.37T
		2000	2010	2018
Sm <sub>2</sub> Co <sub>17</sub>	Br =	1.1T	1.18T	

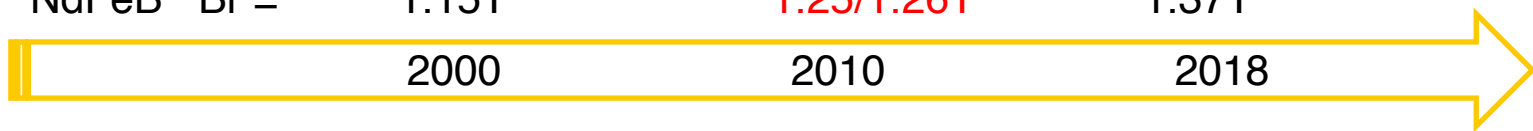

- at cryogenic temperatures with huge coercivities H<sub>cj</sub> > 5000-6000 kA/m

NdFeB	Br =	1.6T @ 135K	
		2000	2010      2018
PrFeB	Br =		1.7T @ 77K or lower

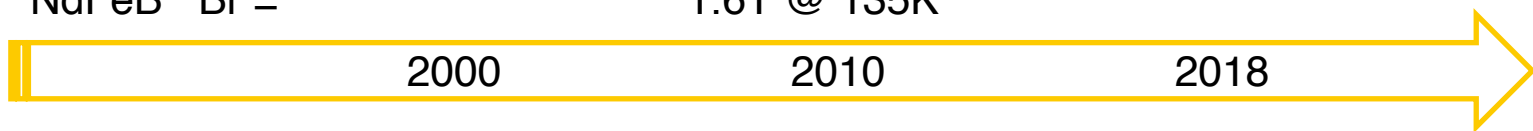

# Magnet improvements: Temperature

Higher performance by heavy rare-earth elements diffusion technology

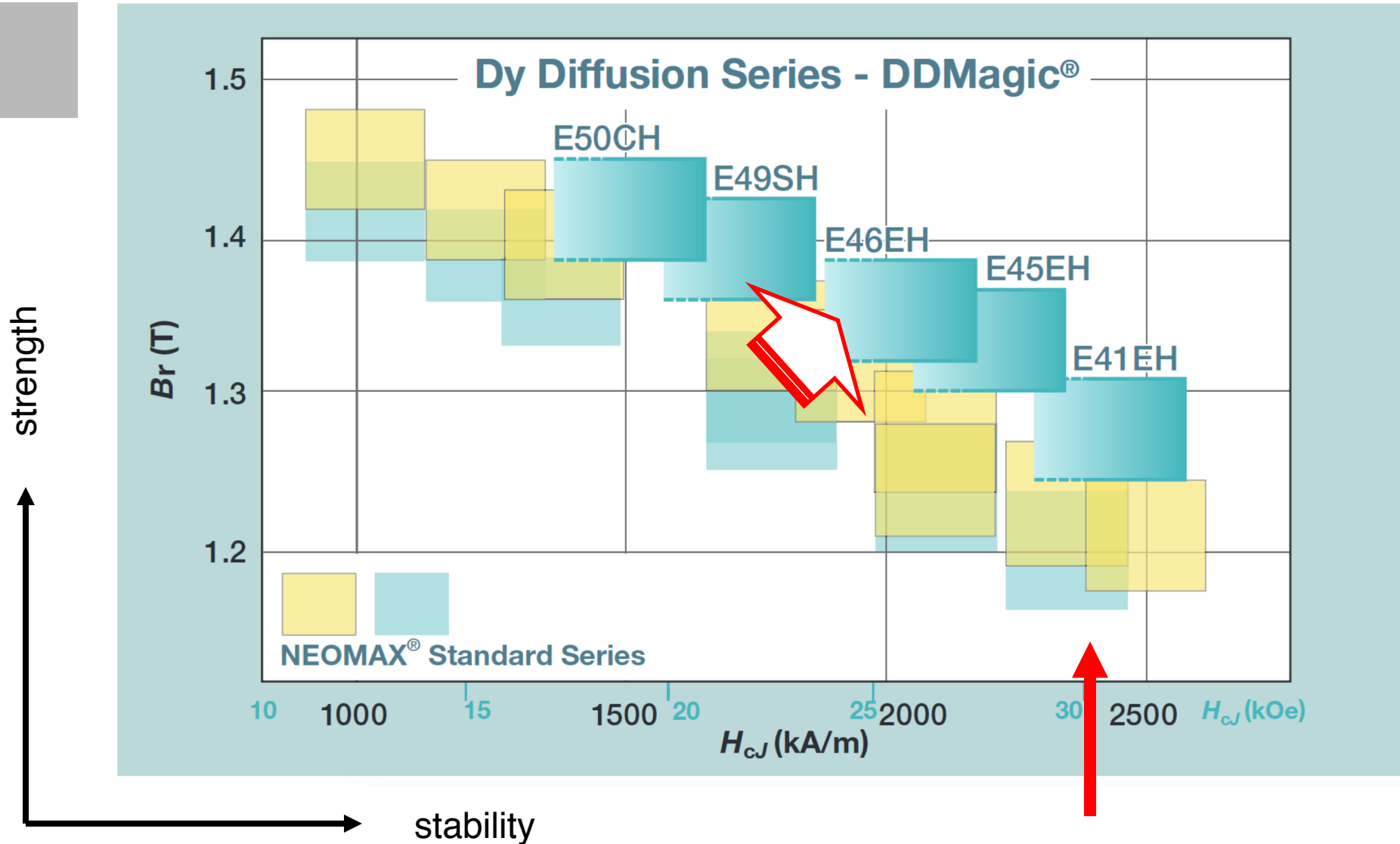

# Magnet improvements: Diffusion

Dy or Tb diffusion to increase coercivity

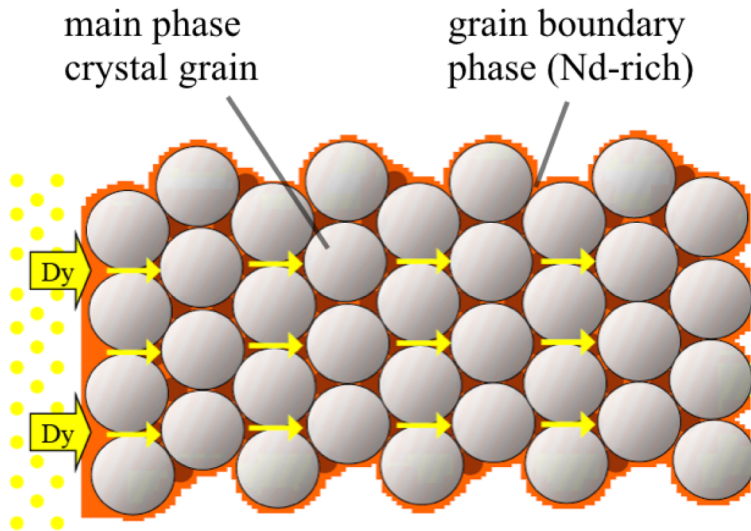

**A Grain**

$(\text{Nd,Dy})_2\text{Fe}_{14}\text{B}$

Conventional

$\text{Dy}_2\text{Fe}_{14}\text{B}$

Dy Deposition Diffusion

Dy Enriched Layer

Electron-Probe Micro Analysis

NEOMAX

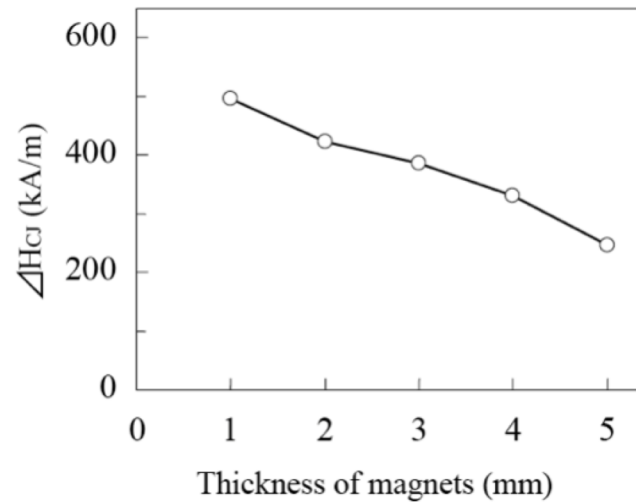

(all figures courtesy: Hitachi Metals Ltd)

# Magnet improvements: Temperature

use  $dBr/dT$  and  $dH_{cj}/dT$

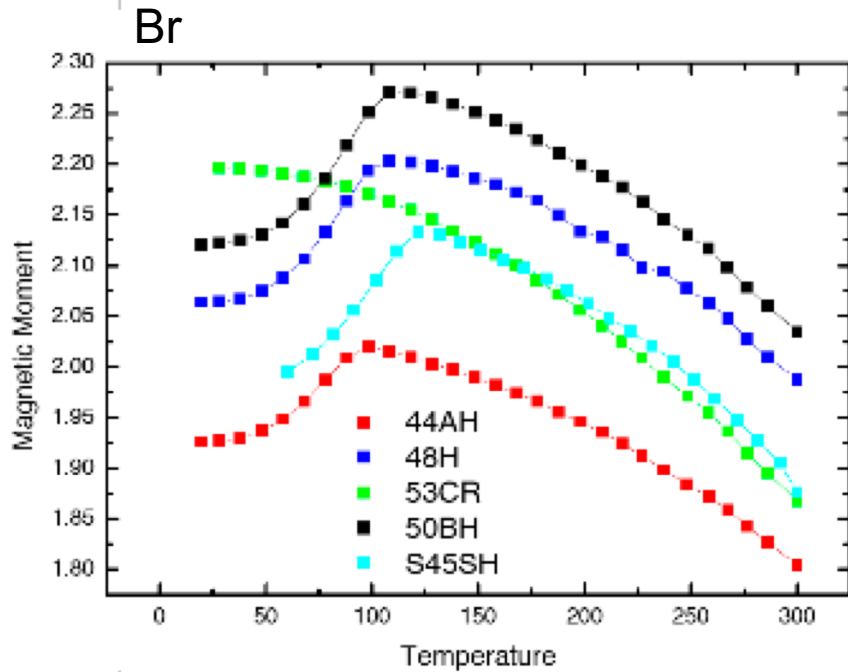

high field  $\Leftrightarrow$  small period

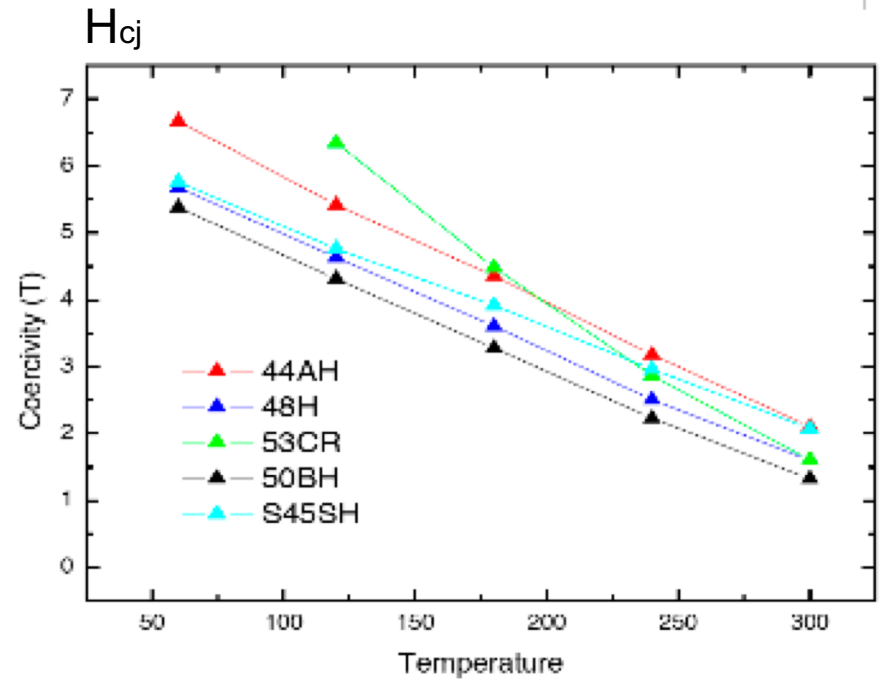

high stability  $\Leftrightarrow$  small gaps

**CPMU** cryogenic permanent magnet undulator

H<sub>cj</sub>: 2400kA/m  $\Rightarrow$  > 6000kA/m

Br: 1.3T  $\Rightarrow$  1.7T

# Magnet improvements: Diffusion

Higher performance by heavy rare-earth elements diffusion technology

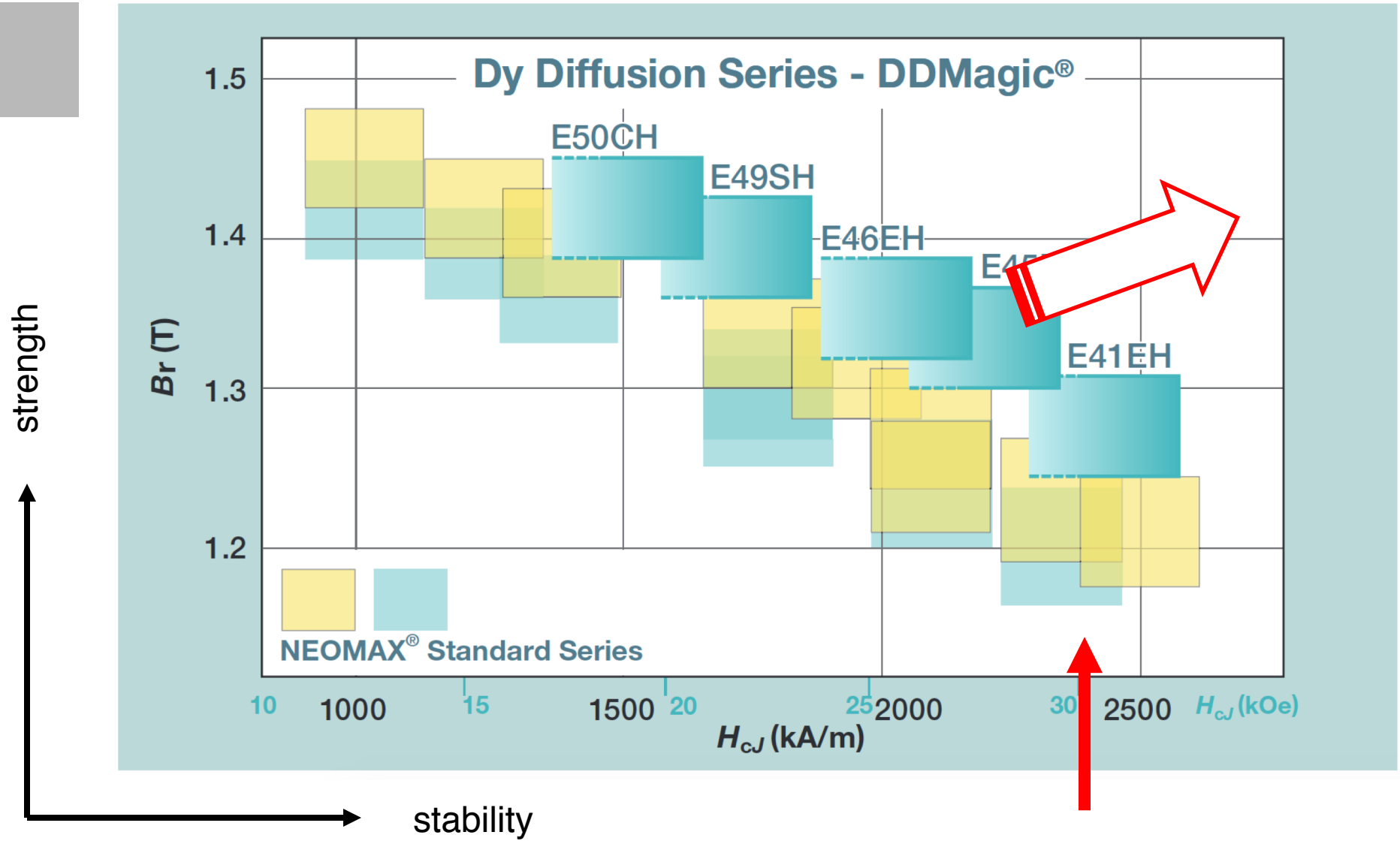

# Period length for 17.5 GeV

Electron Energy [GeV]	period length [mm]	gap [mm] vacuum	Br [T]	K - value	Photon Energy [keV] $K_{\max} - K = 1$	
17.5	15	4.4	1.25	1.2	113	SwissFEL RT S38EH
17.5	15	3.0	1.25	1.8	74	
17.5	15	4	1.7	1.76	76	CPMU
17.5	20	5	1.7	2.39	37-100	
17.5	22	5	1.7	2.84	26-88	SmCo: K = 1.3
17.5	25	5	1.7	3.5	16-78	SC: K = 3.93
17.5	35	7.5	1.7	3.76	10-55	SC: K = 3

magnetic gap = vacuum gap + 0.2mm

# SwissFEL: undulator concept

## SLS 2.4 GeV

**soft x-ray** variable polarization

APPLE II

twin UE56 (<- BESSY II)

UE54 soft & tender x-ray

fixed gap UE44

quasi-periodic elm

**hard x-ray**

in - vacuum (<- SPring-8)

work horses: U19 -> 20keV

CPMU U14 -> 30keV

gap min = 4mm, 2m long

2.9 - 3.4 GeV **SwissFEL** 2 – 5.8 (7) GeV

soft x-ray variable polarization

APPLE-X

UE38, Chic Modes

in - vacuum

U15 3mm, 4m long -> 12keV

U10 sc ?! (2025 ff) -> 36keV

construction phase I  
2013-2016

2. Konstruktionsphase  
2017-2020

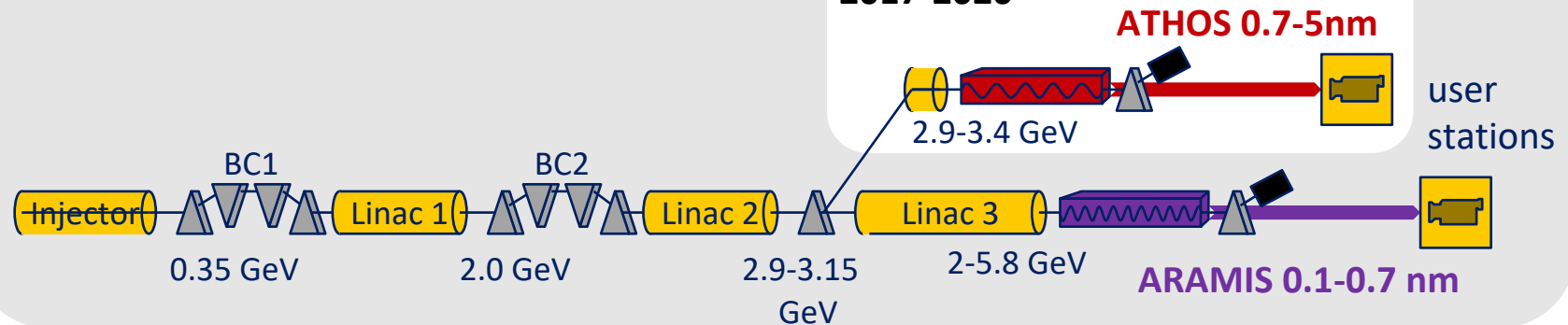

## Aramis

Hard X-ray FEL,  $\lambda=0.1-0.7$  nm

Linear polarization, variable gap, in-vacuum Undulators

First users 2017

## Athos

Soft X-ray FEL,  $\lambda=0.65-5.0$  nm

Variable polarization, Apple undulators

First users 2020

## Main parameters

Wavelength from	1 Å - 70 Å
Photon energy	0.2-12 keV
Pulse duration	1 fs - 20 fs
e <sup>-</sup> Energy	5.8 GeV
e <sup>-</sup> Bunch charge	10-200 pC
Repetition rate	100 Hz

# SwissFEL ARAMIS U15



## new design:

closed O-shaped frame

wedge based gap drive

staggered bellow array

chamfered pole pieces

block keeper extruded & sliced

flexor keeper design

precise tuning with adjustable wedge

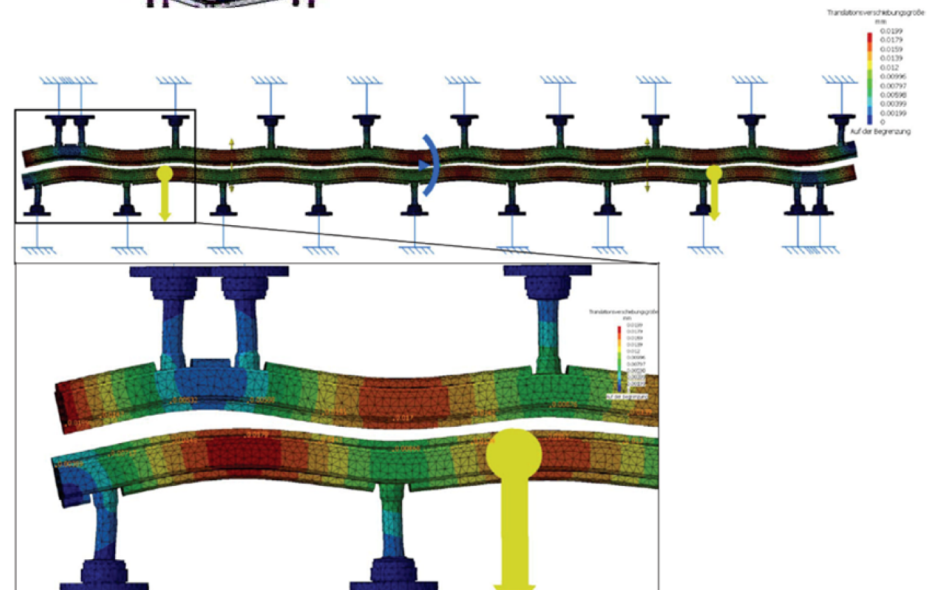
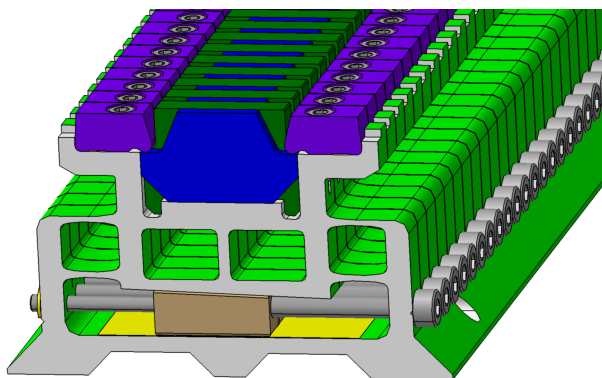
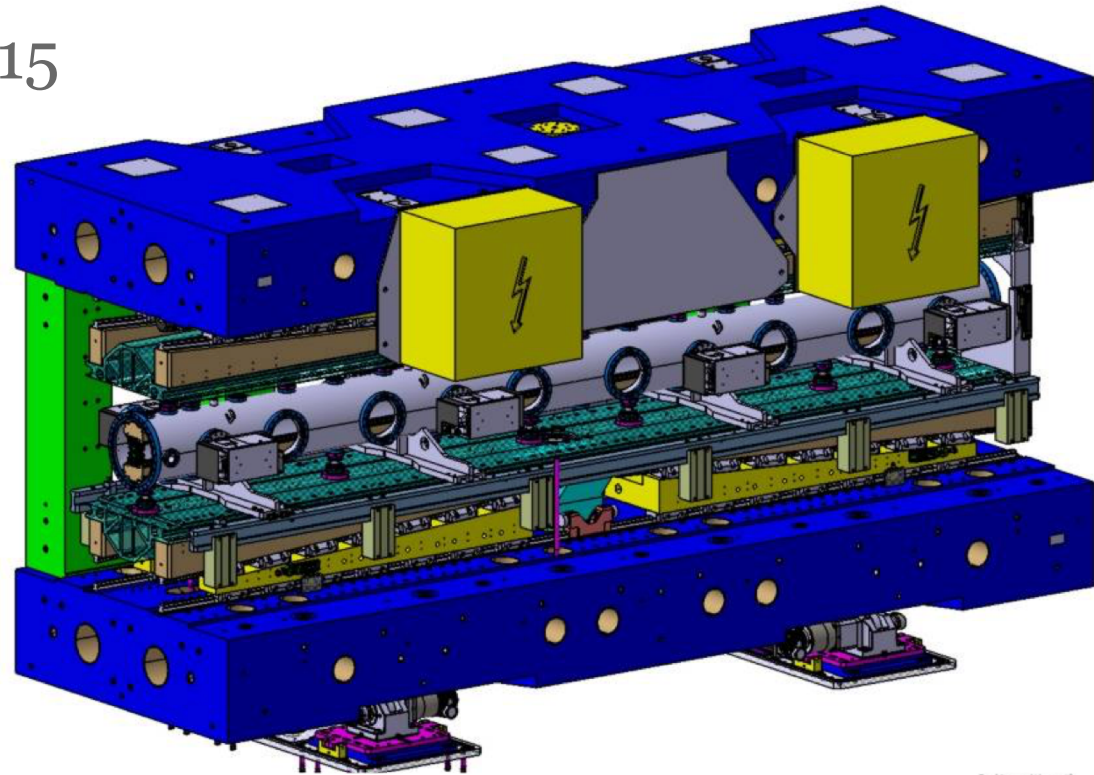

good field region  $\pm 30 \mu\text{m}$

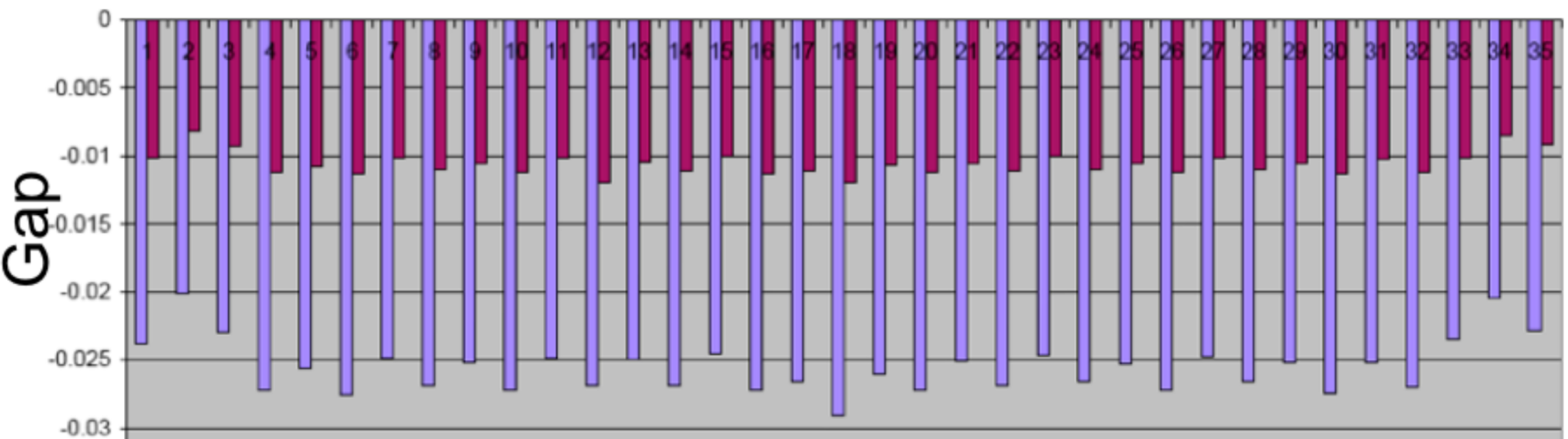
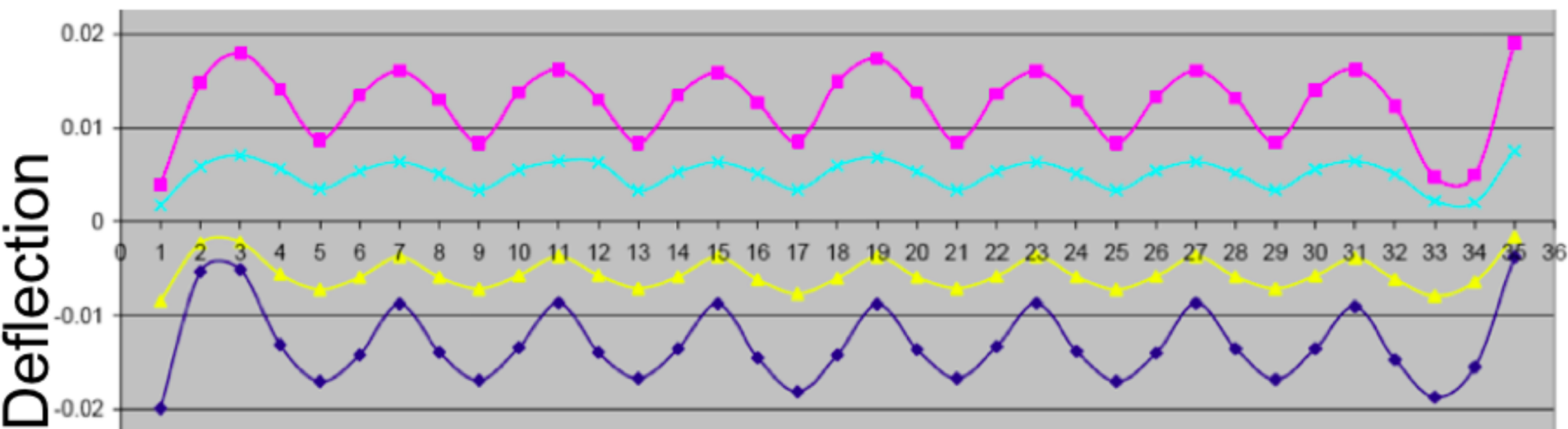

gap:  $1 \mu\text{m} = 3 \text{ Gauss}$

# SwissFEL: Aramis U15

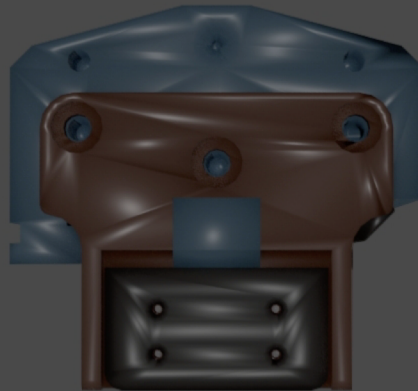

# PSI measurement benches

Laser based SAFALI Measurement systems<sup>1)</sup>:

1<sup>st</sup> without tank: trajectory and phase

2<sup>nd</sup> inside tank: phase and calibration field vs gap

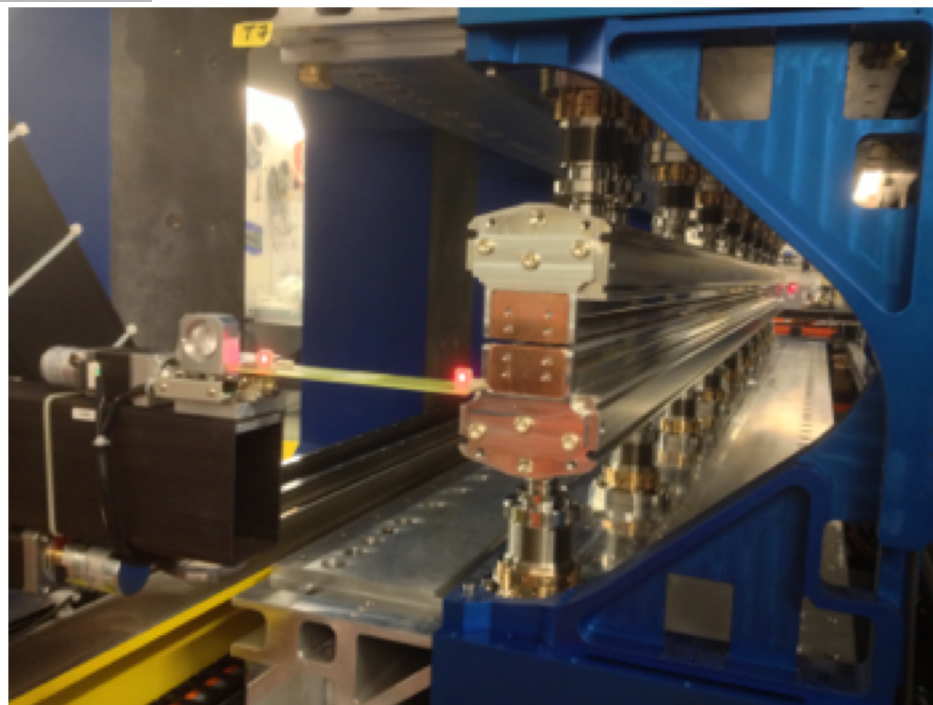

Senis Hall probe, linear motor  
laser based axes stabilization  
Juri 2.0

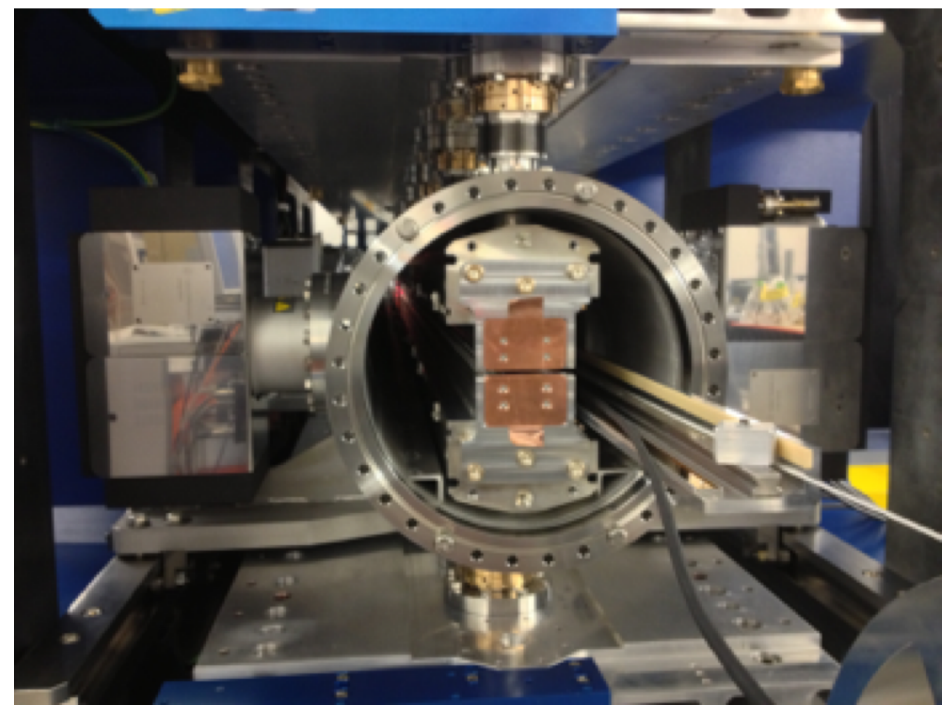

Senis Hall probe, piezo stepper  
laser based axes stabilization

<sup>1)</sup> SAFALI concept by T. Tanaka

## U15 optimization step 1: center the axis

measure axial B

differential screws in columns

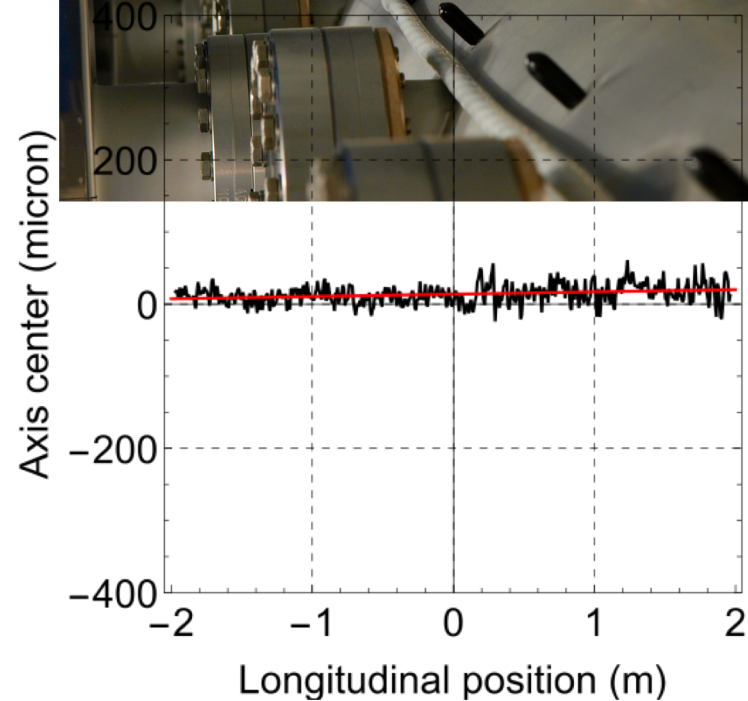
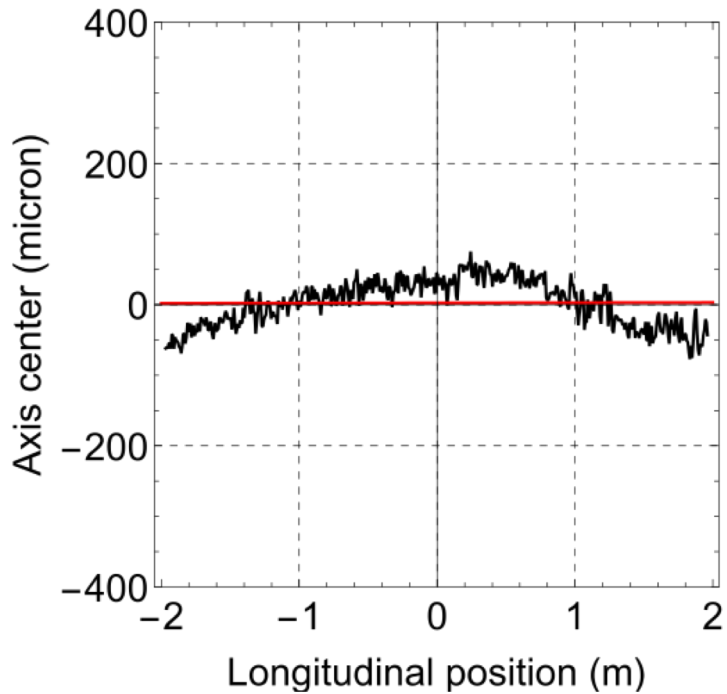

# U15 opt. step 2: long range errors

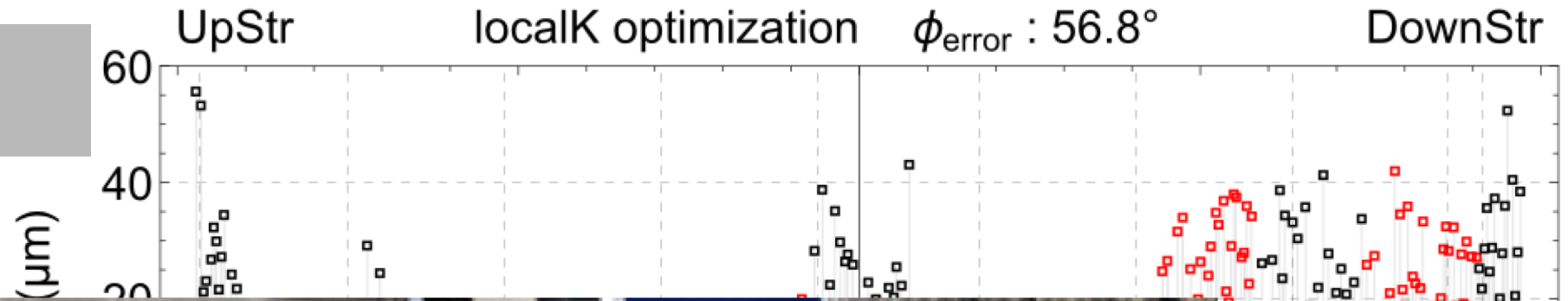

## U15 opt. step 2: long range errors

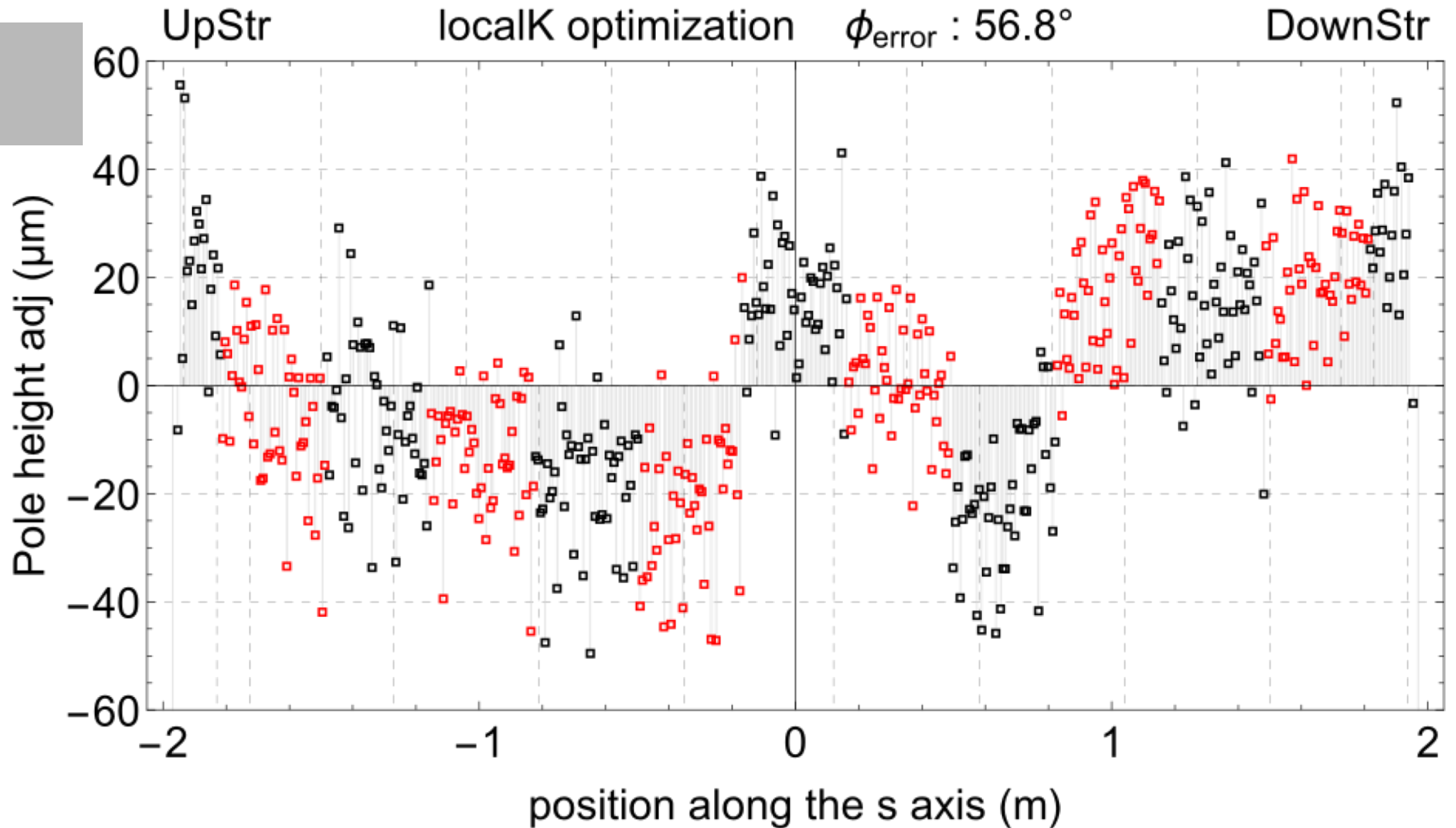

## U15 opt. step 2: long range errors

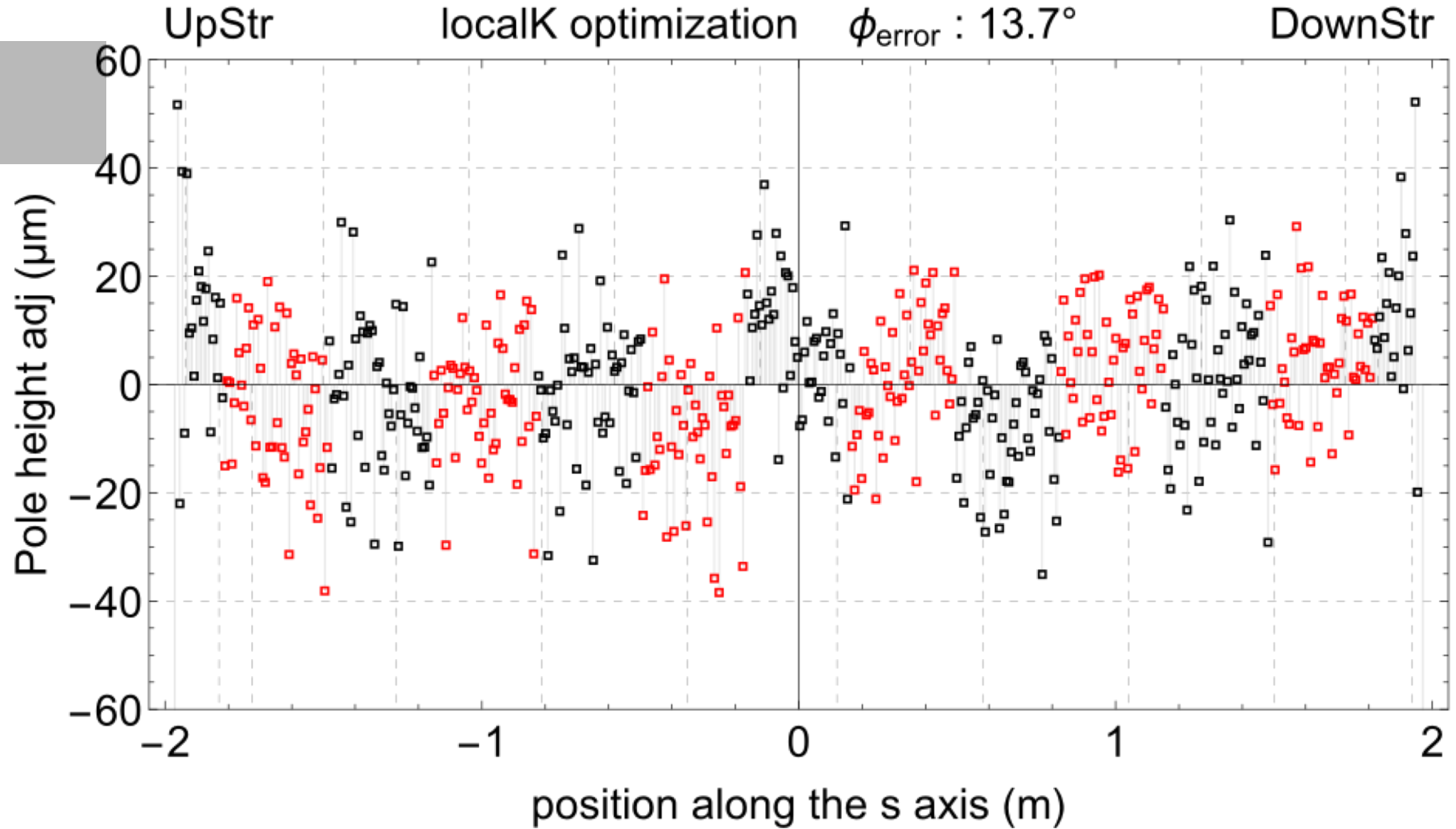

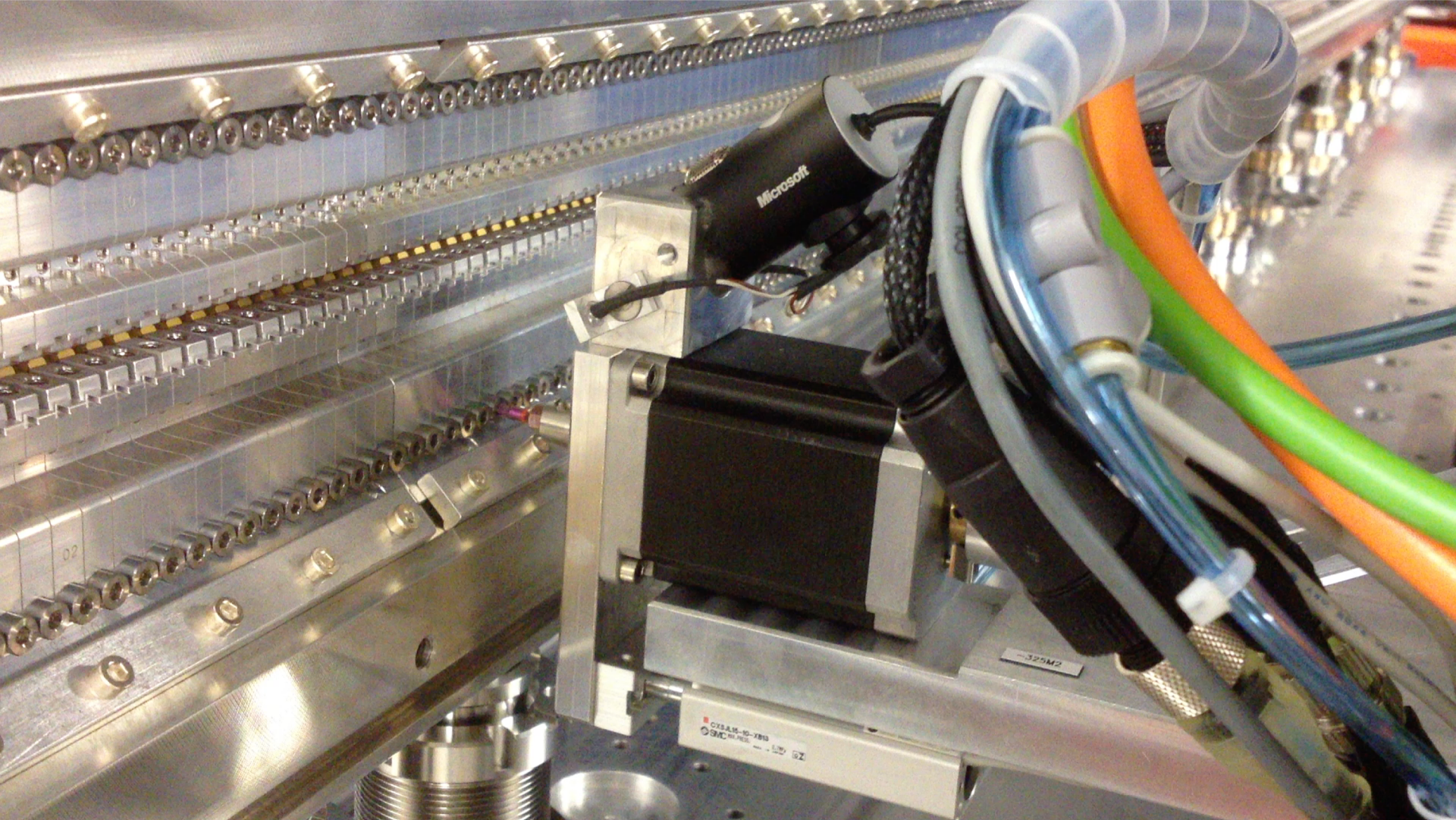

## U15 opt. step 3: local errors

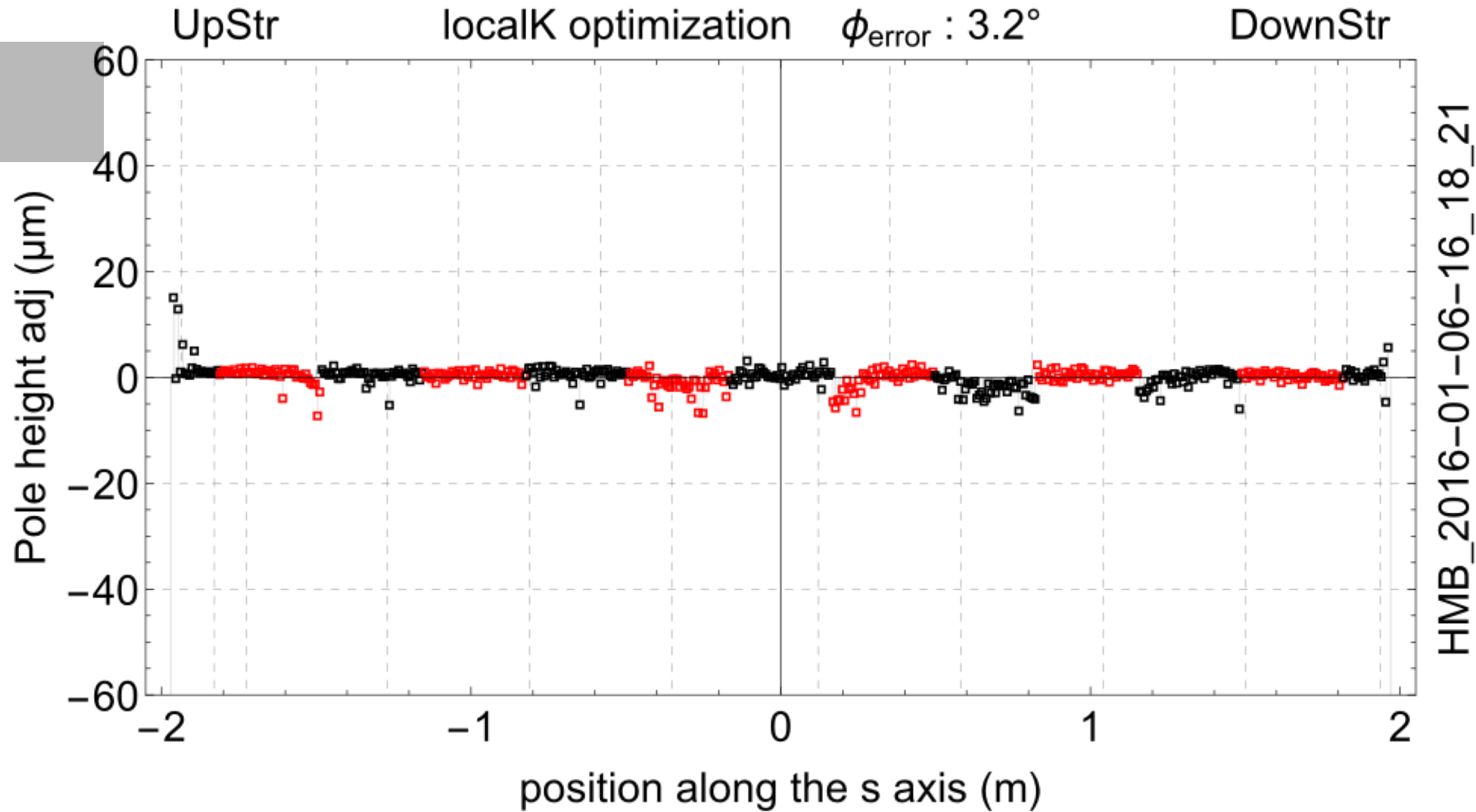
after 1<sup>st</sup> Yuri run

## U15 opt. step 3: local errors

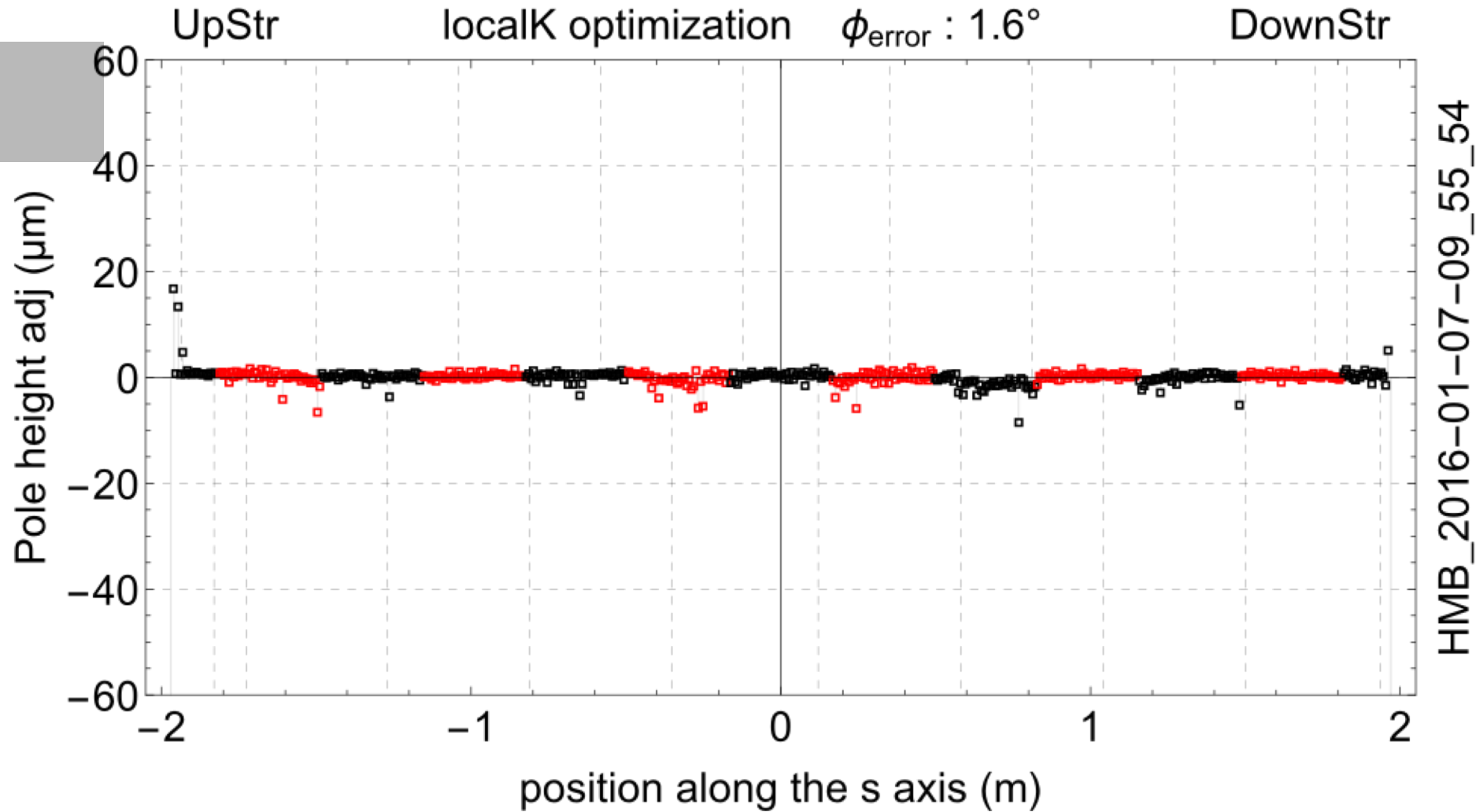
after 3<sup>rd</sup> Yuri run

## IDs for SwissFEL: Aramis U15

kHin: -25.5 kVin: 88.5 (G·cm)  
kHout: 56.7 kVout: -115.7 (G·cm)  
long coil: 4.2 (G·cm)

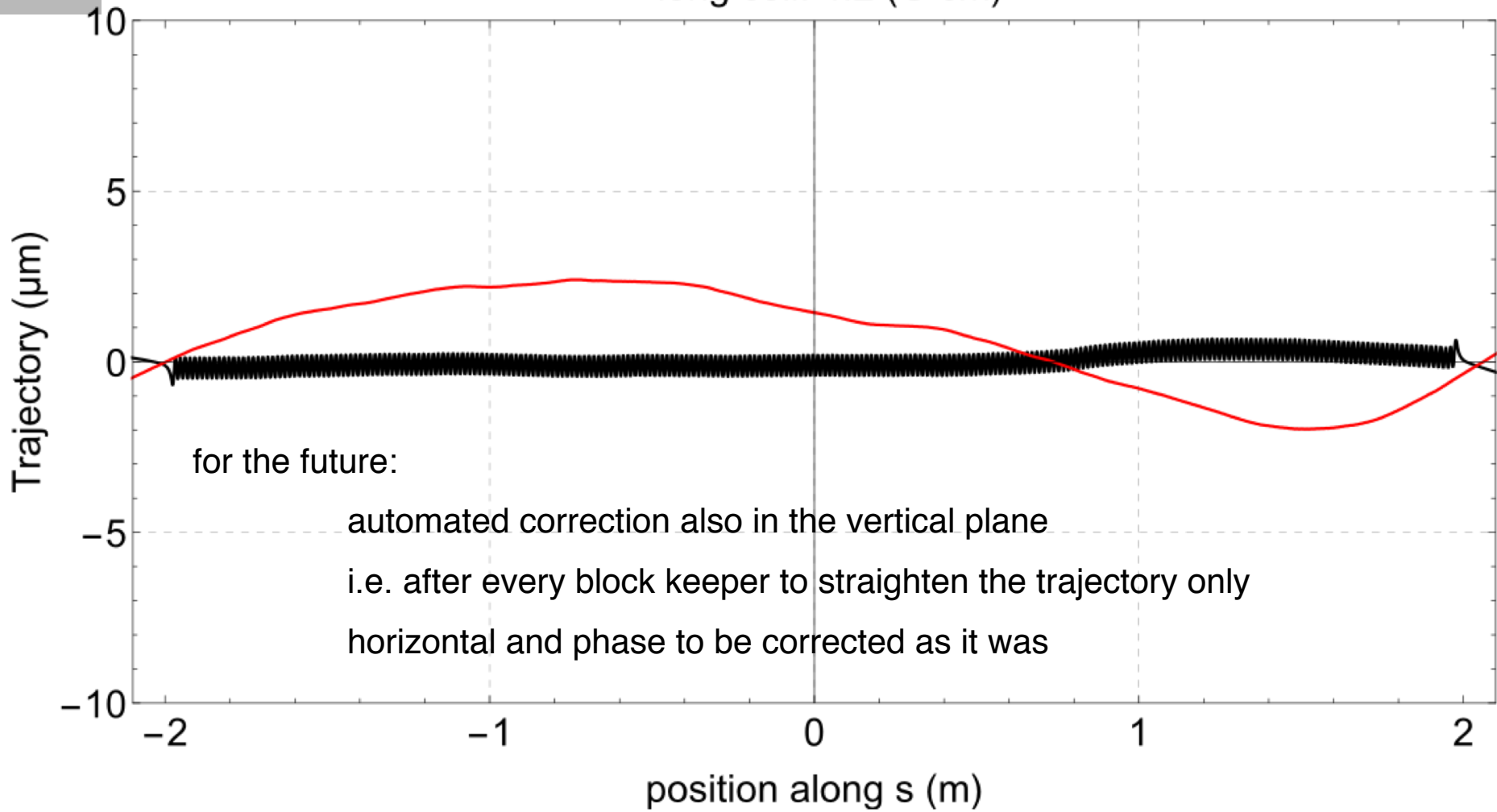

# Aramis U15 Series Performance

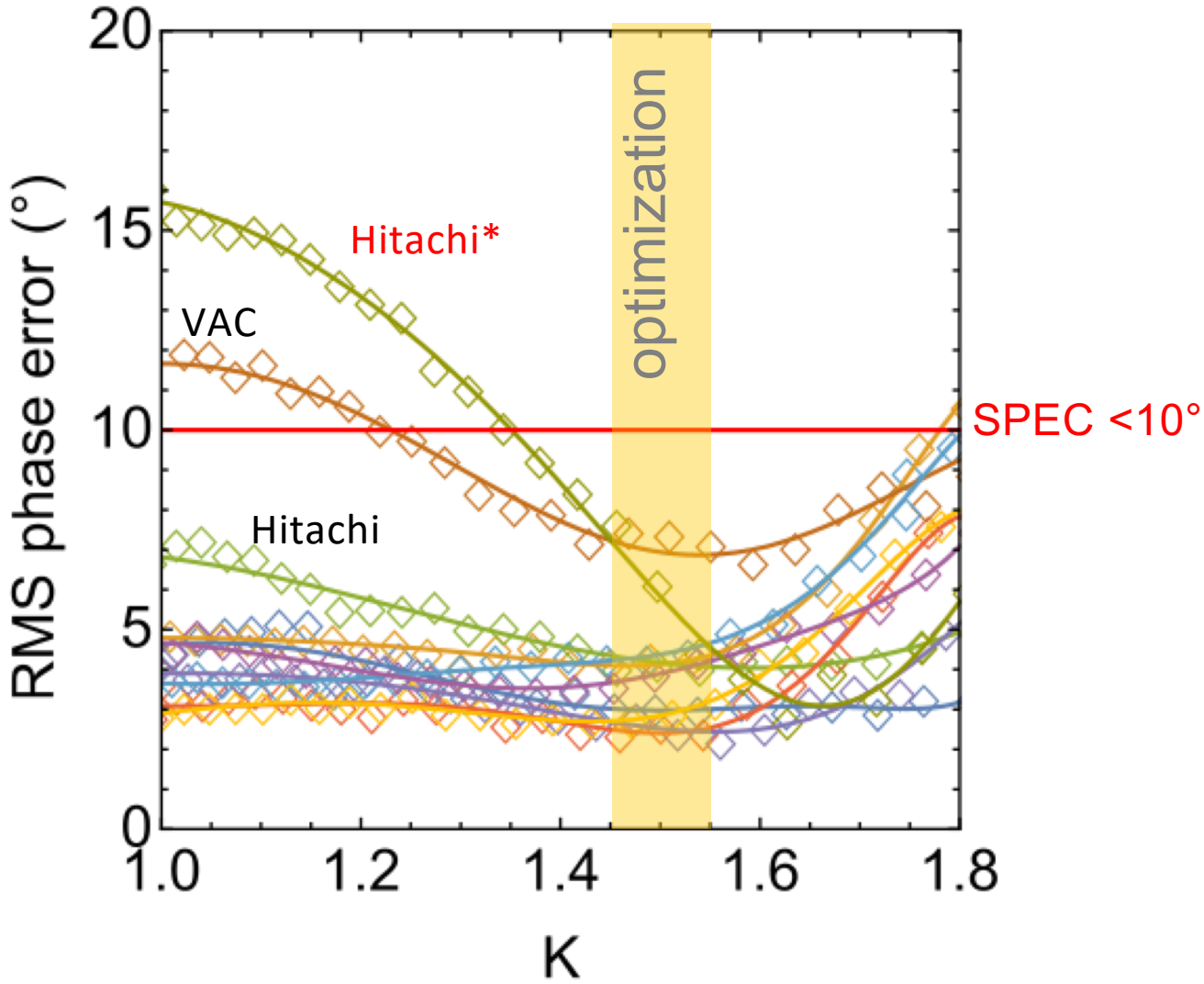

# Undulator Performance: magnet strength

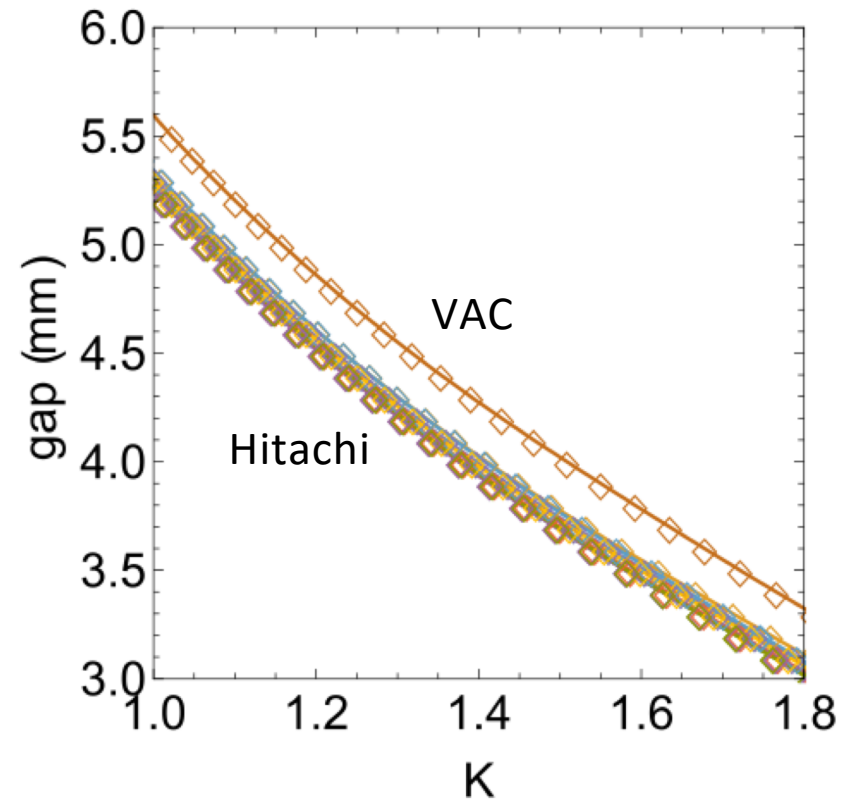
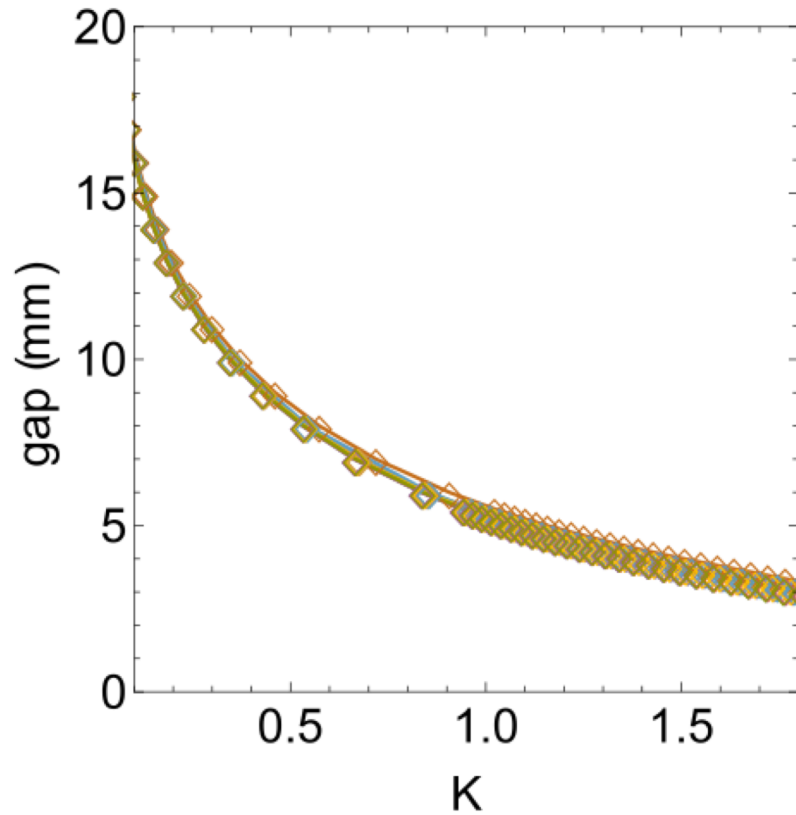

cryogenic in-vacuum undulators differ in

columns: tubes instead of massive rods,

LN2 to room temperature at columns and flexible taper

(remark: at SwissFEL we have no flexible taper at all

but shrinking inner I-beam will increase the gap

-> wakefield studies or flexible taper

flexible taper is the foil (or better a second piece of foil)

for EUXFEL required because of MHz repetition rate?

cooling by cryo cooler or cold head

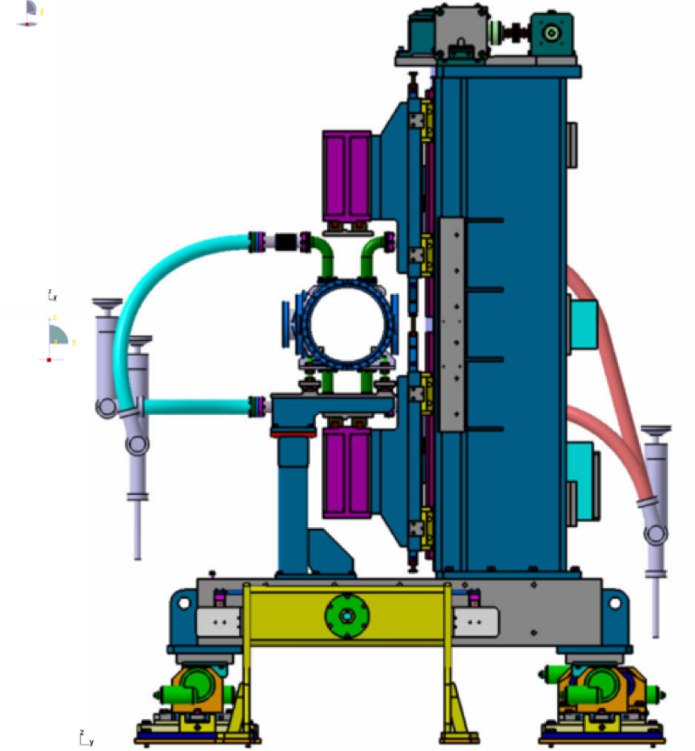
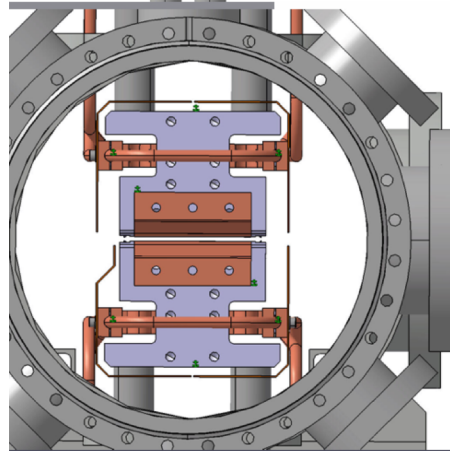
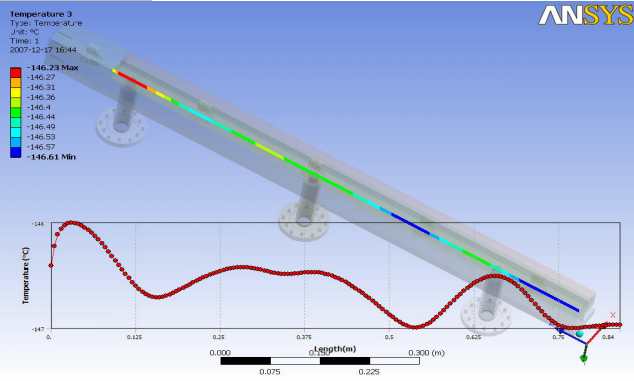
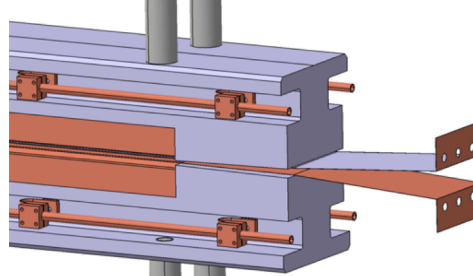
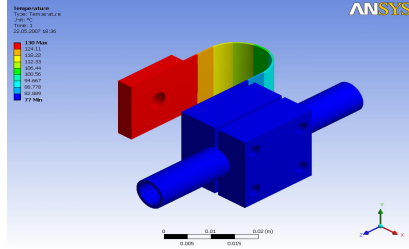

## Challenges:

shrinking of columns: direct gap measurements

measurements under vacuum

**Experience:** phase error changes can be recovered

**Benefit for FEL:** higher K-value or larger gap

very high coercivity and expected radiation hardness

# In-situ Measurement / Optimization Bench

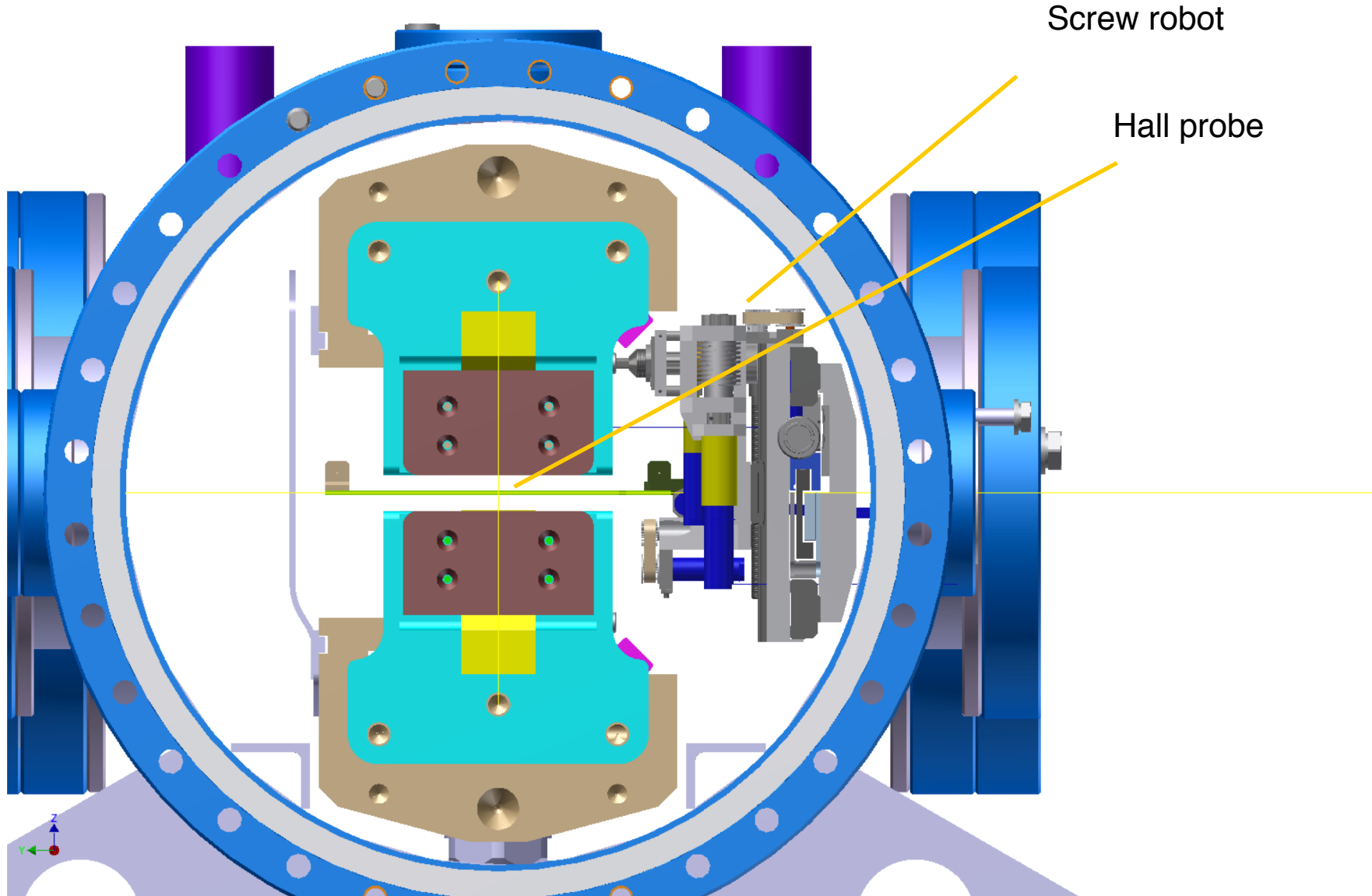

## phase 1 (2013-2016)

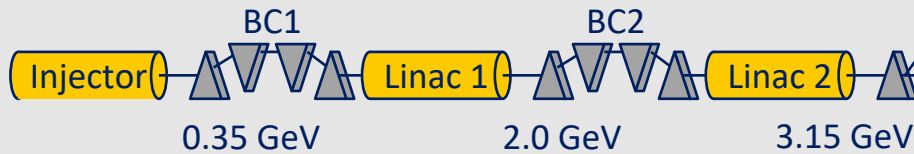

## phase 2 (2017-2020)

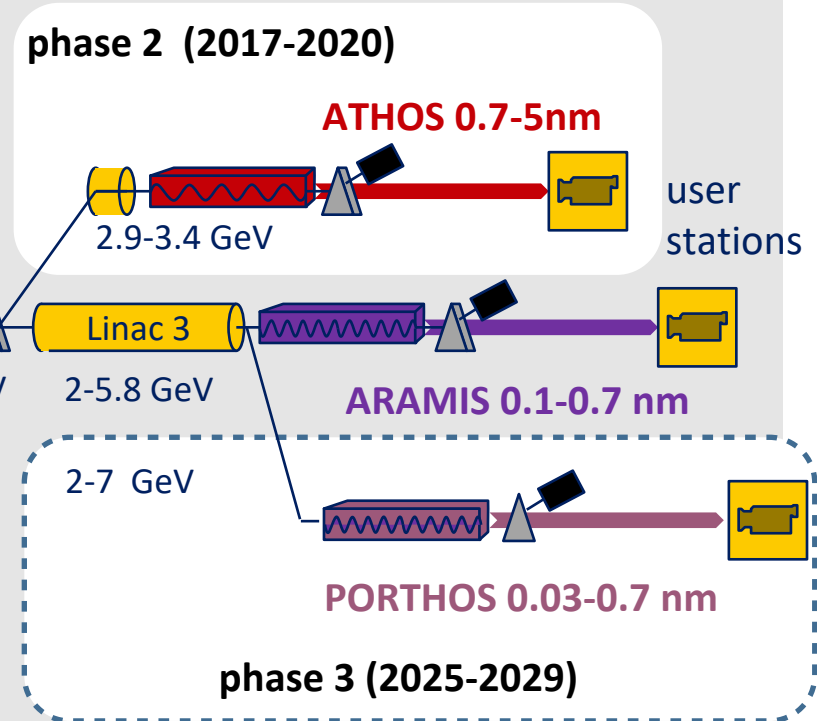

Undulator: U10  $K = 2.4$

# SC undulator performance

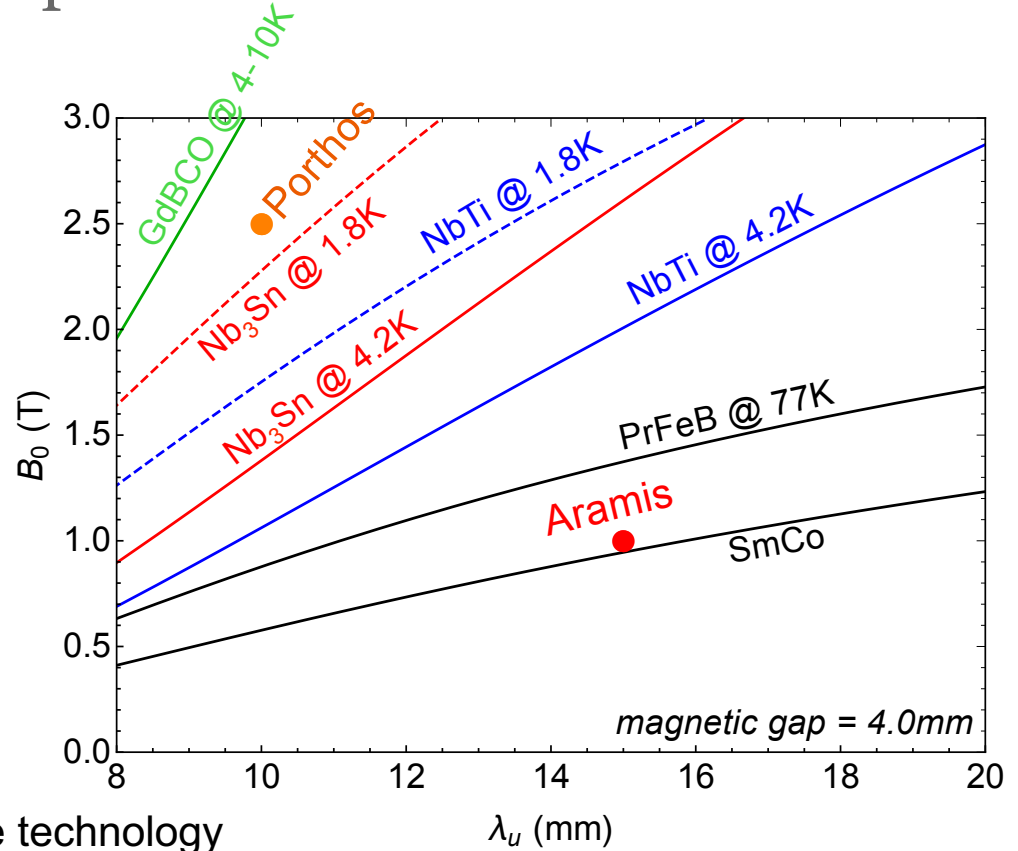

*E.R. Moog, R.J. Dejus, and S. Sasaki, Light Source Note: ANL/APS/LS-348 James Clarke, FLS 2012, March 2012*

**NbTi** electromagnetic undulators mature technology

APS and KIT/BN

Techniques for measuring the field at cryogenic temperature as well as shimming to achieve compatible phase errors have been demonstrated

**Nb<sub>3</sub>Sn**

prototypes LNBL, APS

training behaviour to be understood

# GdBCO short prototype

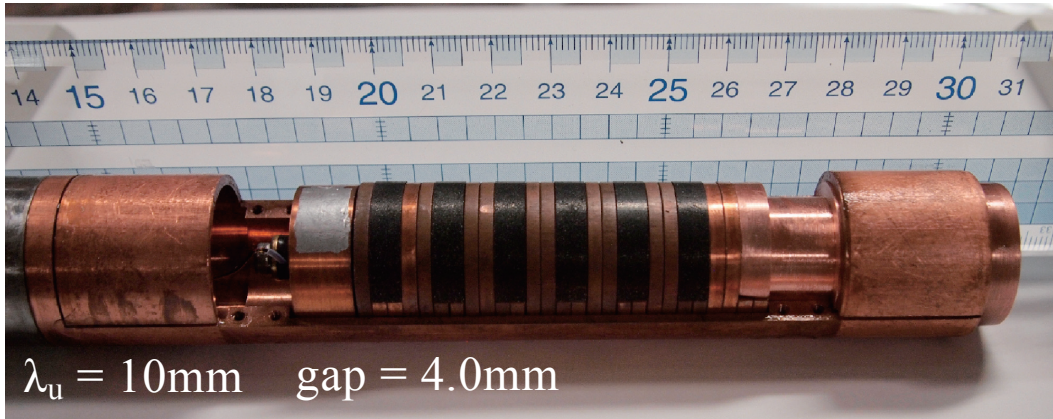

$T_{\text{op}} = 6.0\text{ K}$

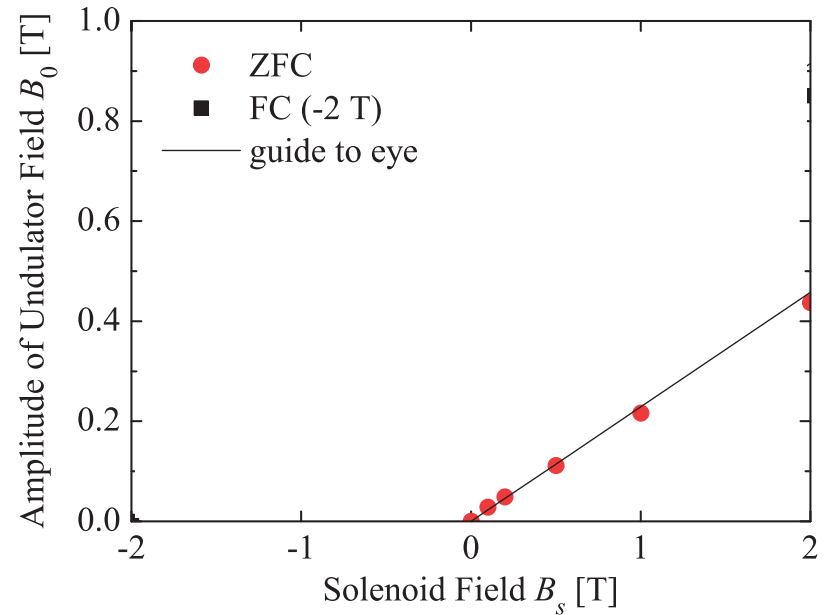
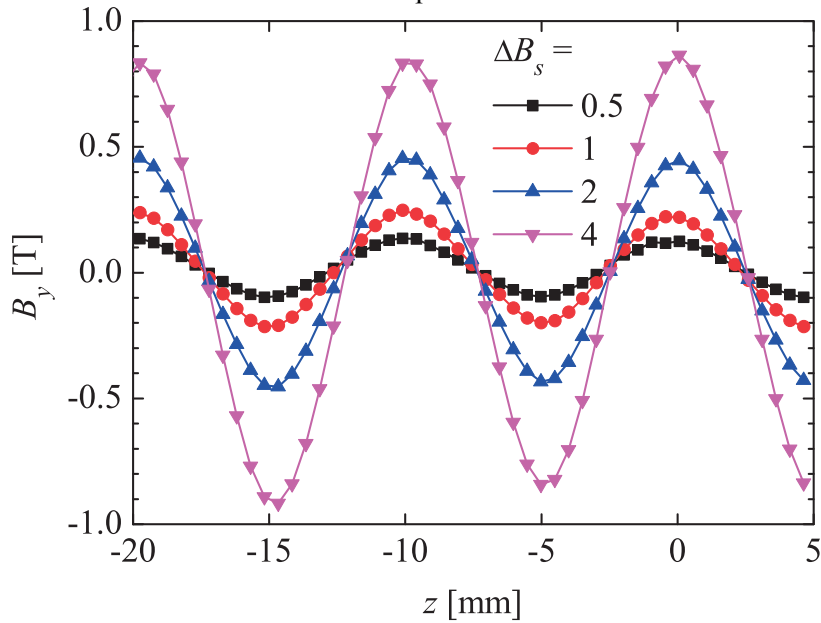

# Planar HTS staggered array

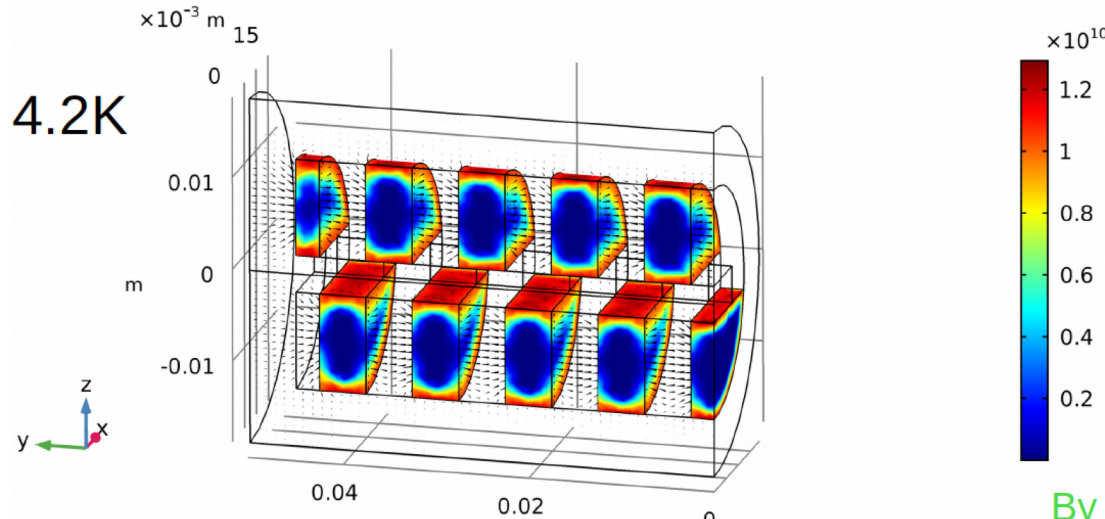

Field cooling in a 10T solenoid background field, yields about **2.0T** undulator field after driving the solenoid to 0T

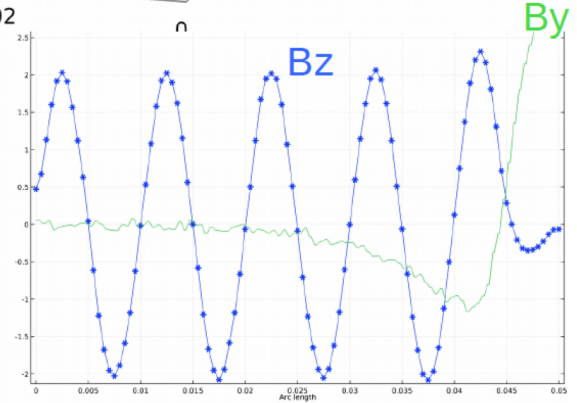
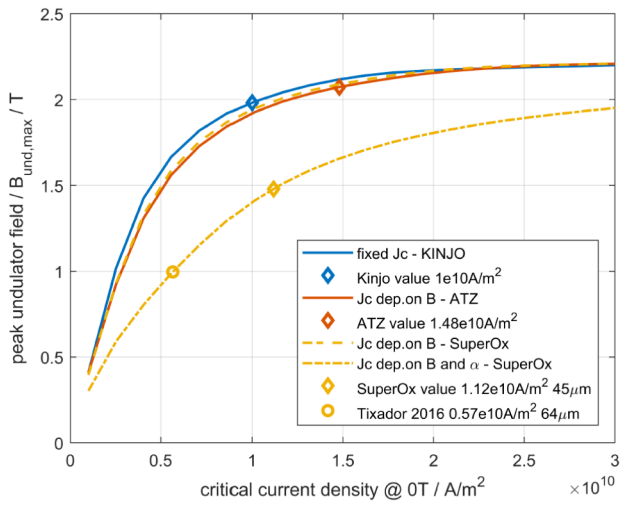

contract signed for a test structure with 6 - 10 periods (University of Cambridge)

# 2D Comsol Simulation

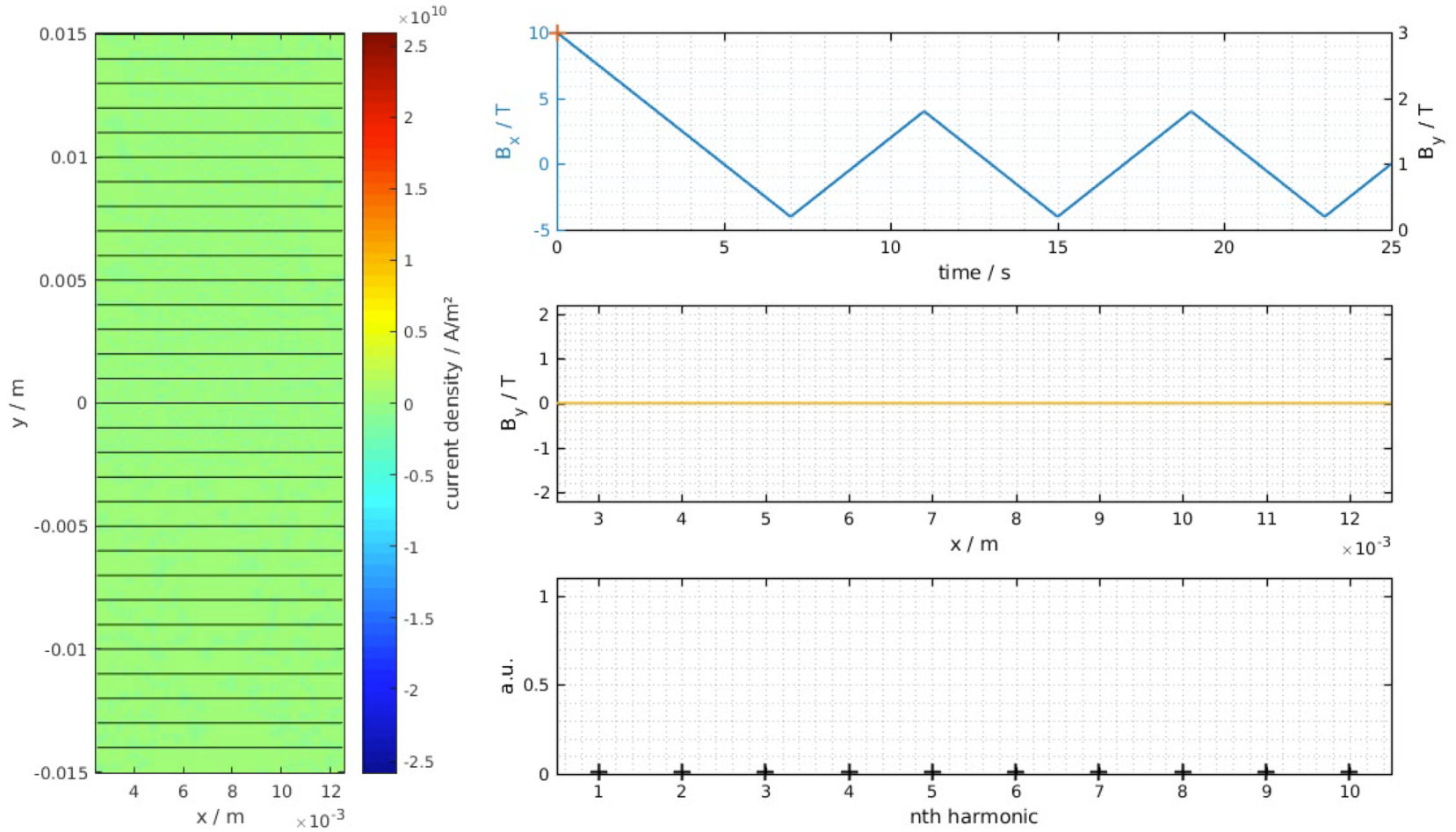

# Helical Undulator - Double Staggered Array

Time=5.2 s Volume: (1/m) Streamline:

4.2K

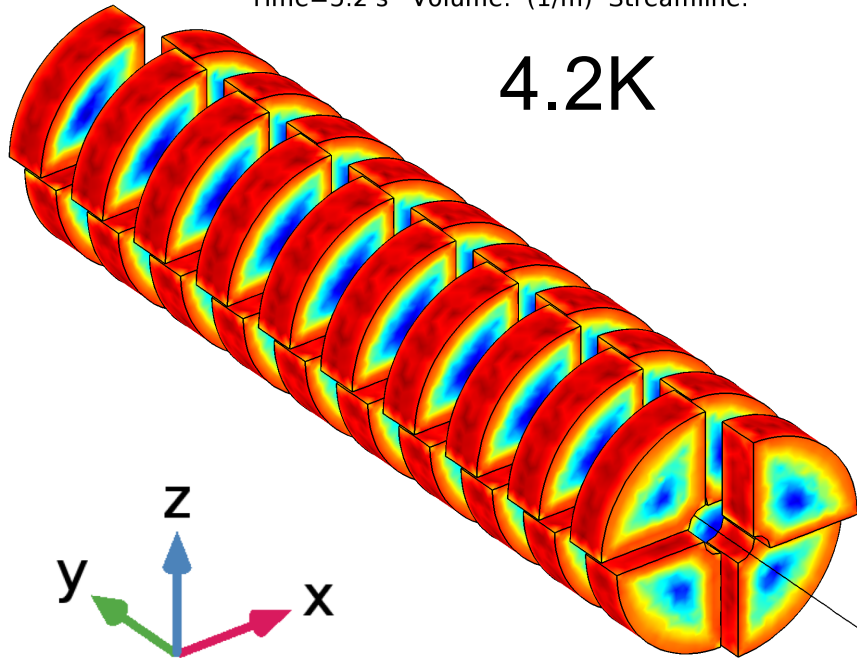

Time=5.2 s Volume: (1/m) Arrow Surface:

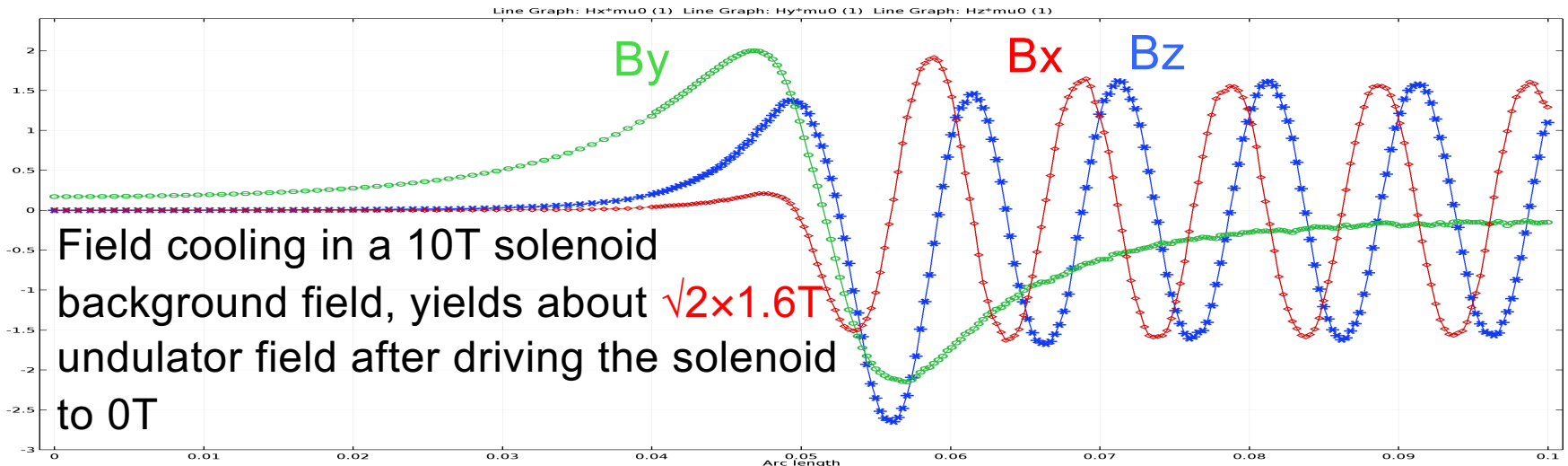
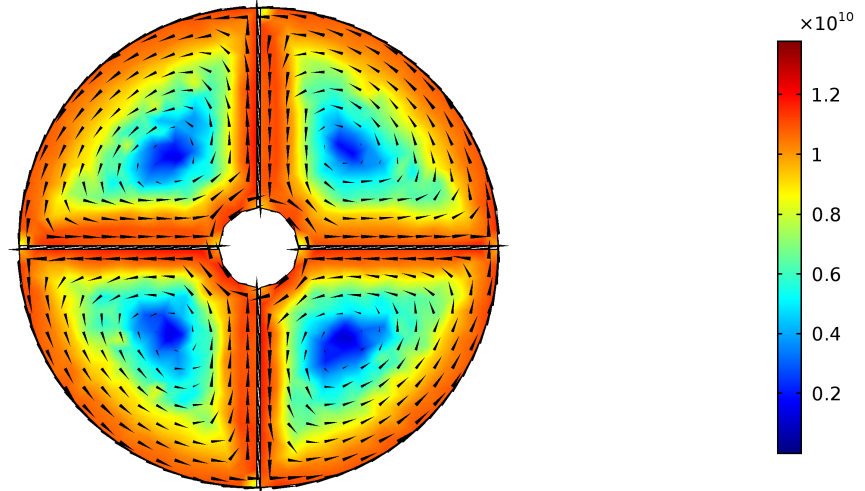

# Conclusion PPM Undulator Technology

room temperature PPM undulators state of the art FELs

out of VAC: LCLS and EuXFEL

in vac: SPring-8, PAL, SwissFEL

CPMU @ LN2 state of the art at storage rings

field increase and radiation hardness, proven technology

⇒ qualifies them also for FEL application

⇒ in competition with sc undulators

R&D advanced HTS undulator schemes

for really small periods in combination with high K-values

“ppm like“ schemes

WIR SCHAFFEN WISSEN – HEUTE FÜR MORGEN



# Thanks for your attention

and thanks to ID group: Marco Calvi, Marc Brügger, Steffen Danner, Lars Huber, Marcus Schmidt, Sebastian Hellmann, Kai Zhang and Peter Huber, Andreas Keller, Pirmin Böhler, Marcel Locher, Marco Hindermann, Karsten Dreyer, Tino Höwler, Heinz Umbricht, Gerhard Ingold, ...

# Operational Aspects: more than 1 gain length per undulator! U15 spontaneous radiation

- Monochromator Energy Scan over the third harmonic, from 6345eV to 6465eV, in steps of 15eV, using Si111 crystals.
- SR from SARUN15 observed on MCP at  $K = 1.2$

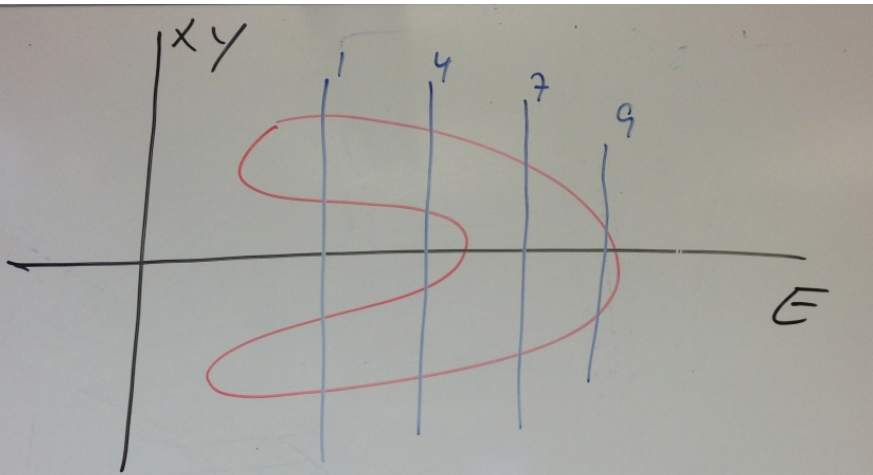

$$\lambda_{\text{rad}} = \frac{\lambda_u}{2\gamma^2} \cdot \left( 1 + \frac{K^2}{2} + \gamma^2 \theta^2 \right)$$

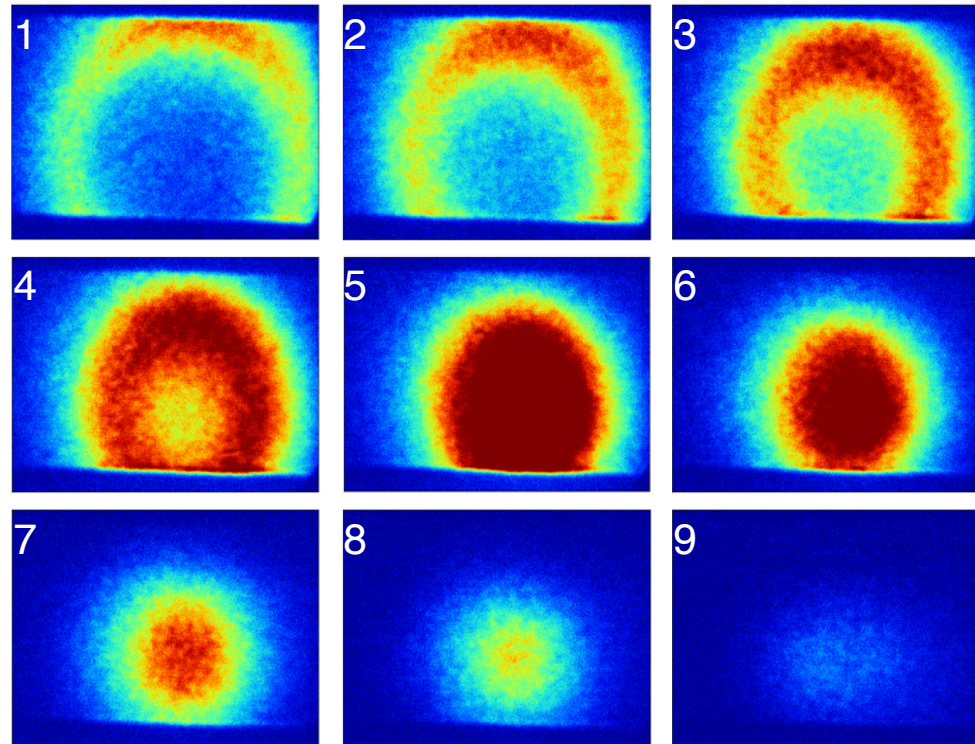

# Individual Pointing Direction

- Undulator being measured set to  $K = 1.2$ , with the rest at  $K = 0.072$  (full open)
- The monochromator was set to 6375eV, third harmonic, using Si111 crystals.

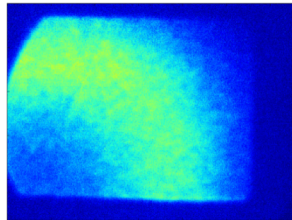

SARUN03

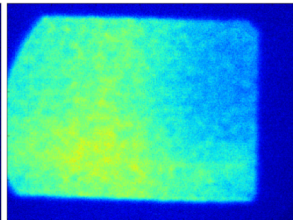

SARUN04

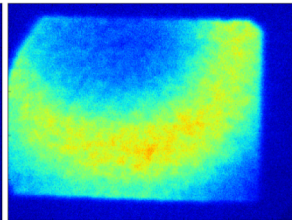

SARUN05

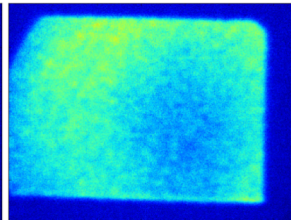

SARUN06

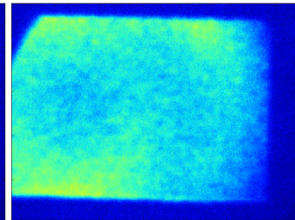

SARUN07

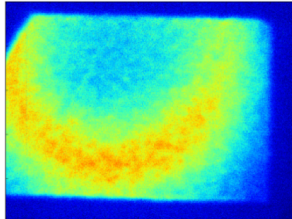

SARUN08

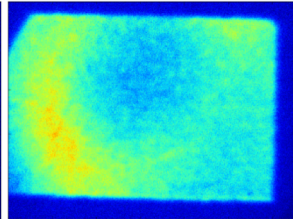

SARUN09

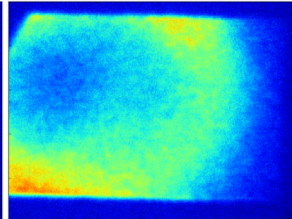

SARUN10

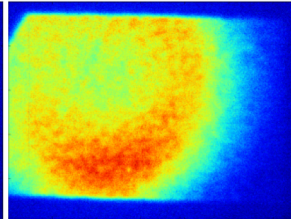

SARUN11

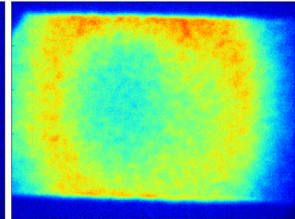

SARUN12

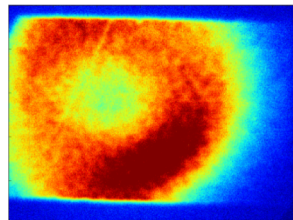

SARUN13

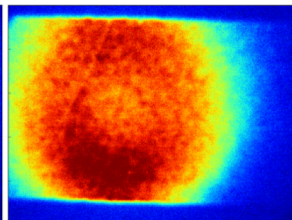

SARUN14

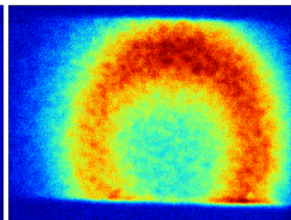

SARUN15

**Need to fine adjust  $K$  and electron trajectory in the individual undulators**

# First time resolved Pilot Experiment by SwissFEL: Semiconductor to metal transition in $Ti_3O_5$ nanocrystals

Collaboration:  
SwissFEL and M. Cammarata et al.,  
Univ. Rennes

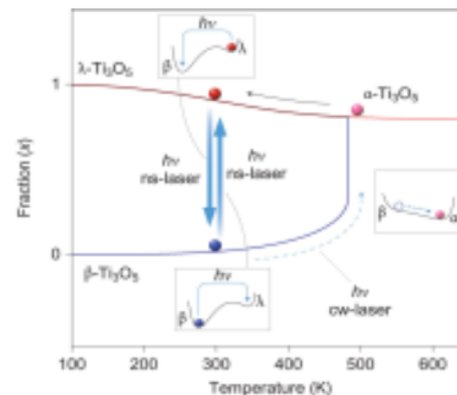

-3<sup>rd</sup> Harm: 6.6 KeV  
(fund. 2.2 KeV 220  $\mu$ J)  
-Laser: 800nm, 42 mJ/cm<sup>2</sup>

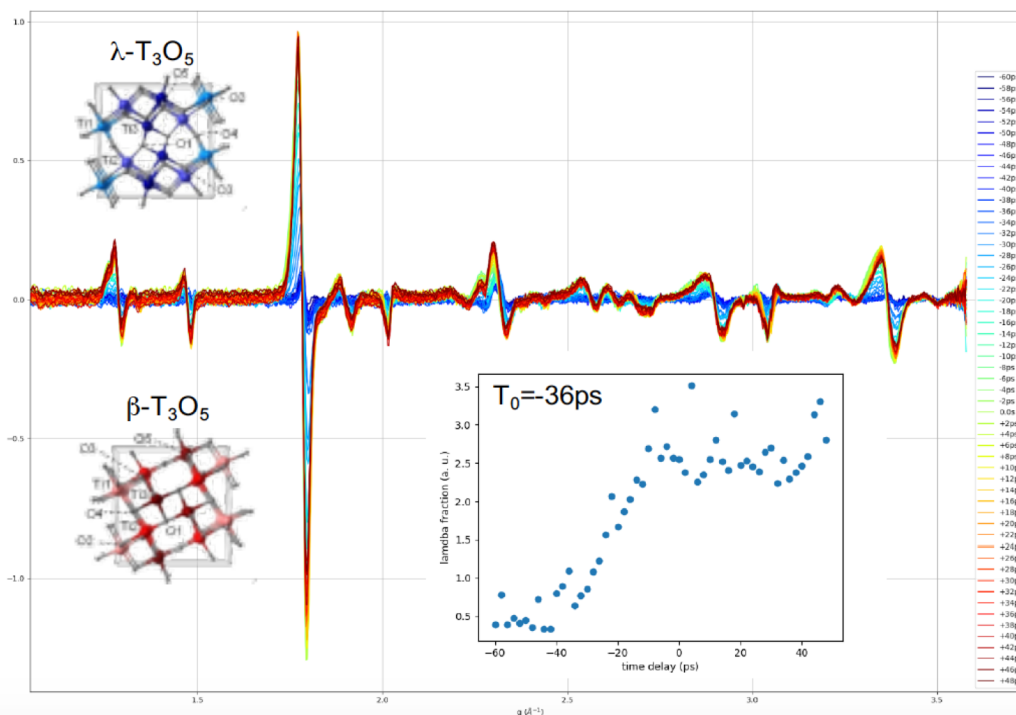
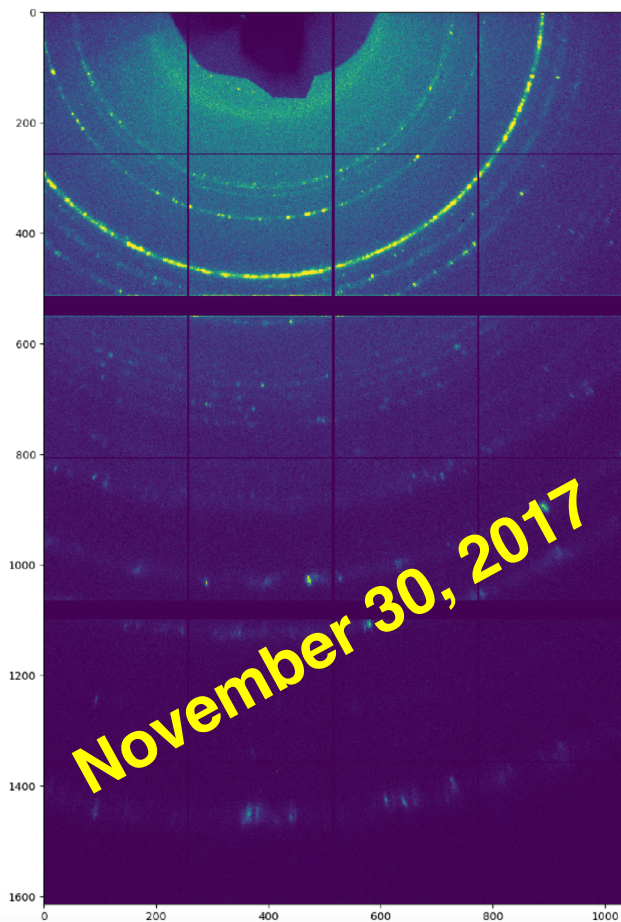

# SwissFEL in a nutshell

**construction phase I  
2013-2016**

**2. Konstruktionsphase  
2017-2020**

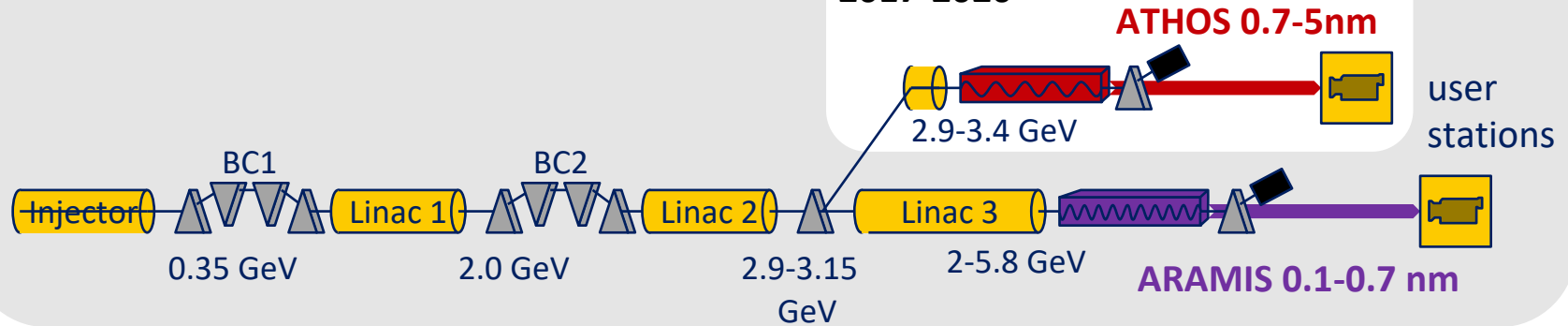

## Aramis

Hard X-ray FEL,  $\lambda=0.1-0.7$  nm

Linear polarization, variable gap, in-vacuum Undulators

First users 2017

## Athos

Soft X-ray FEL,  $\lambda=0.65-5.0$  nm

Variable polarization, Apple undulators

First users 2020

## Main parameters

Wavelength from	1 Å - 70 Å
Photon energy	0.2-12 keV
Pulse duration	1 fs - 20 fs
e <sup>-</sup> Energy	5.8 GeV
e <sup>-</sup> Bunch charge	10-200 pC
Repetition rate	100 Hz

# SwissFEL UE38 (APPLE X)

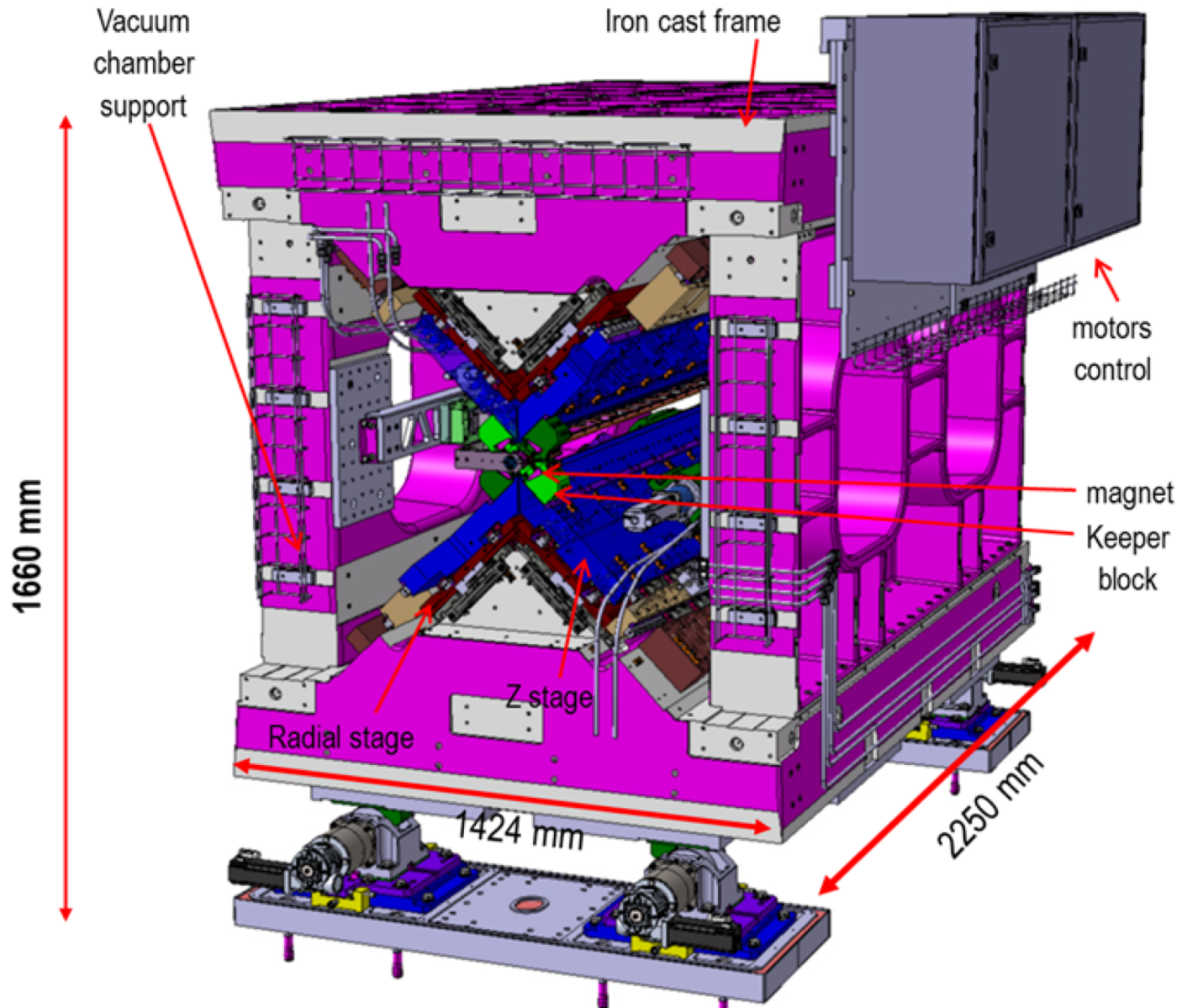

# UE38 keeper block

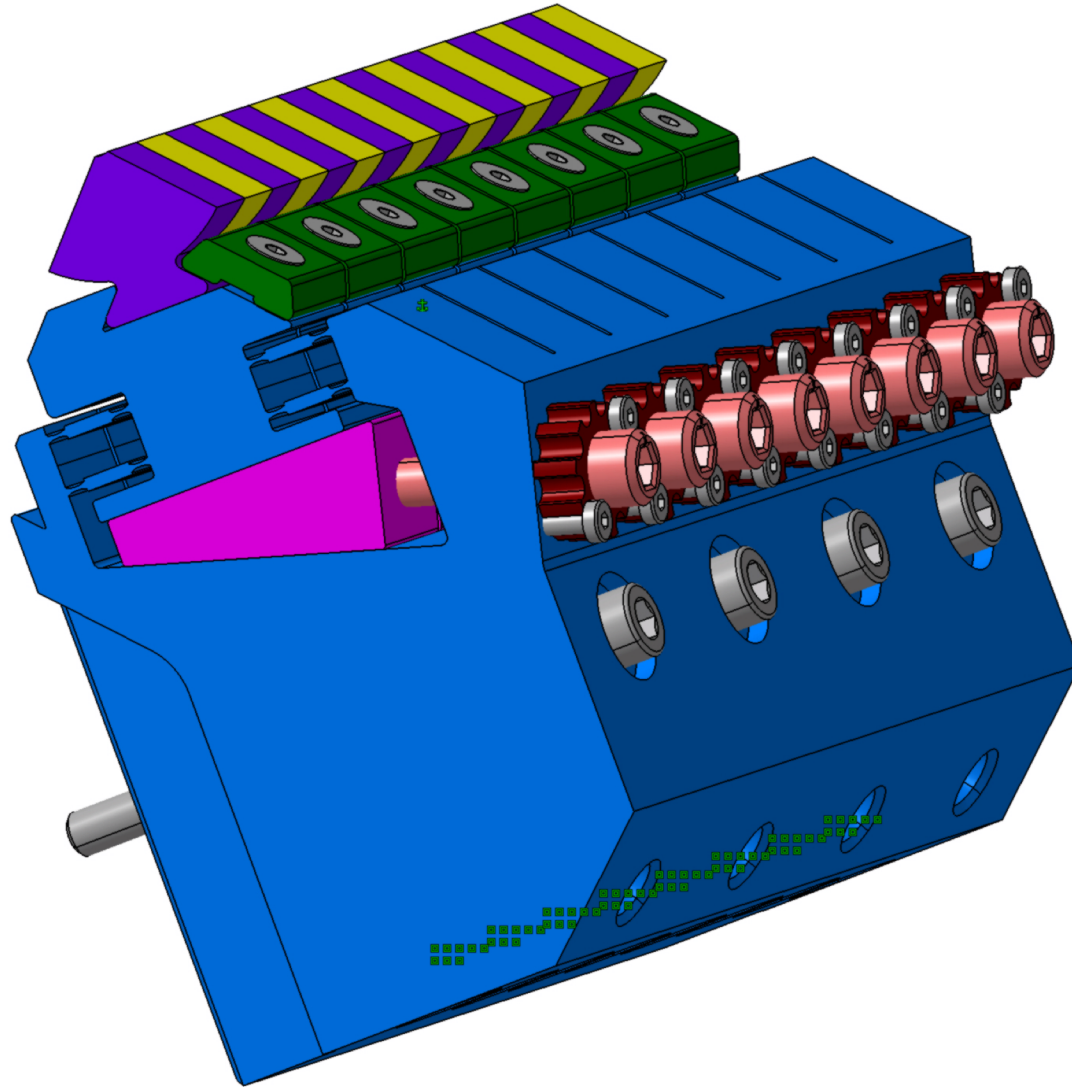

Serial block  
4 periods each



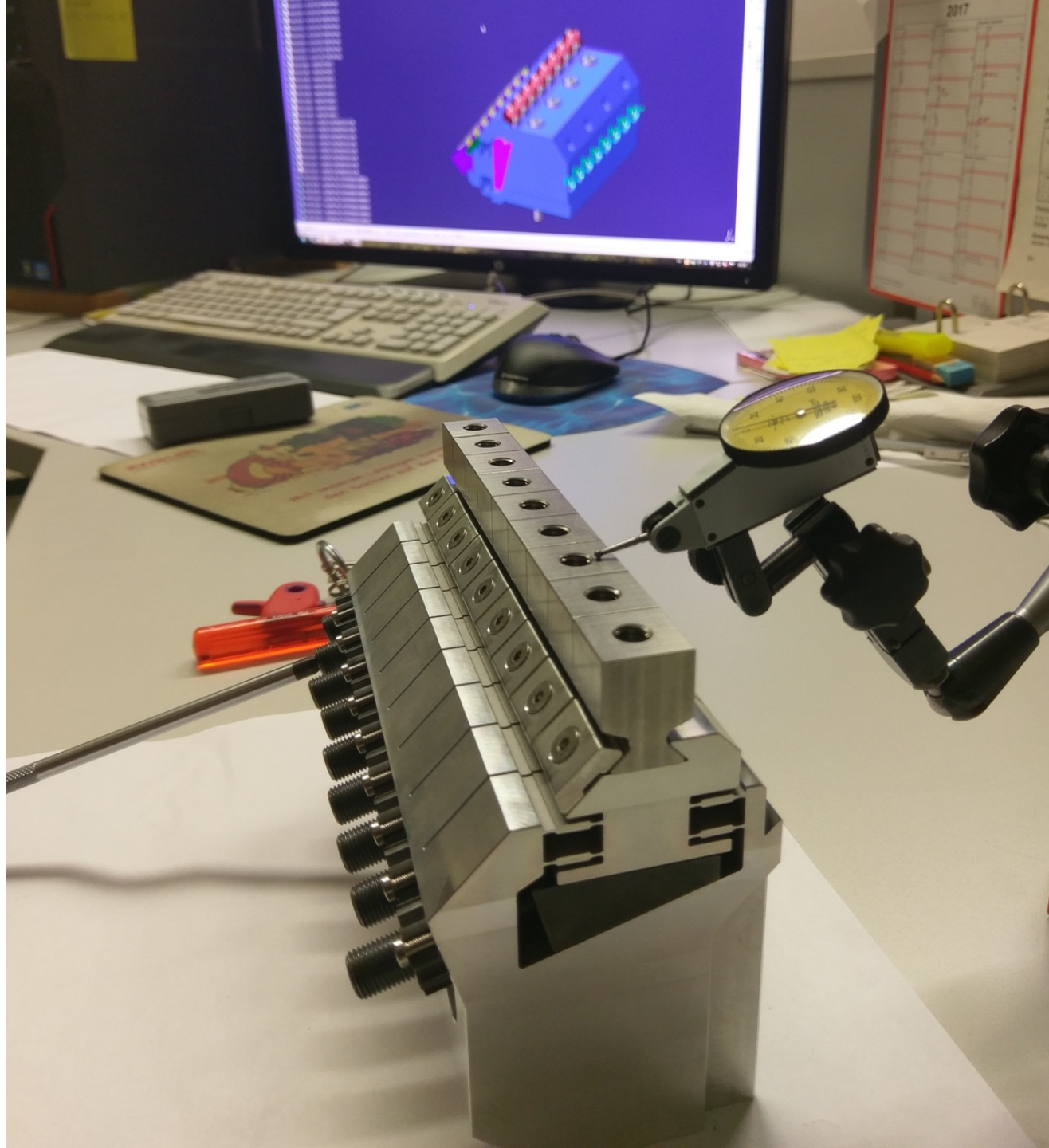

# Ultra-thin Vacuum chamber for UE38

Cu chamber supported by undulator

- galvanic on silicon hose, electro polished  
round or elliptical up to 2:1
- tubes from goodfellow
  - soldered
  - welded

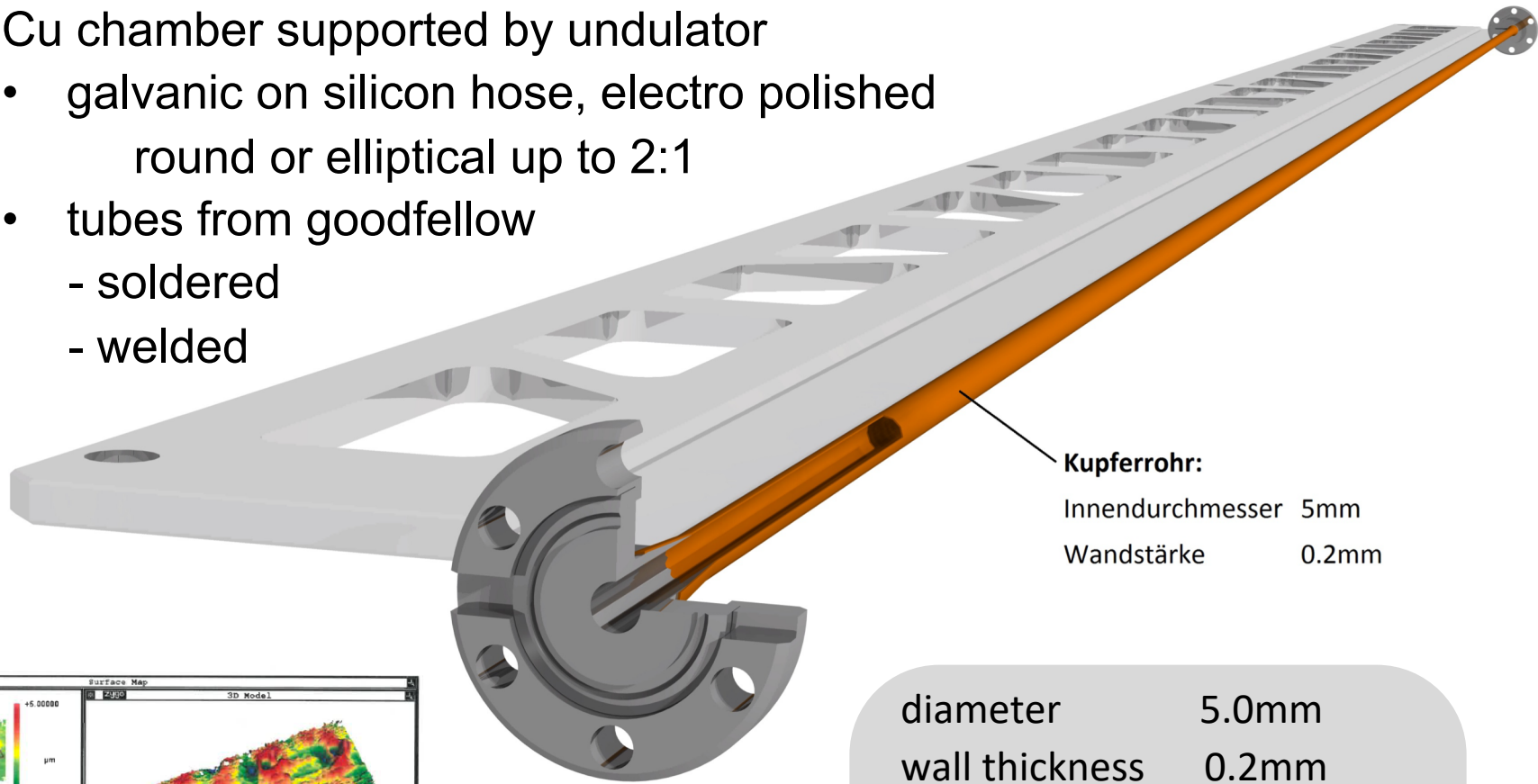

**Kupferrohr:**

Innendurchmesser 5mm

Wandstärke 0.2mm

diameter 5.0mm  
 wall thickness 0.2mm  
 magnet aperture 6.5mm  
 minimum gap 3.0mm  
 surface roughness: Ra 0.5µm  
 after process optimization

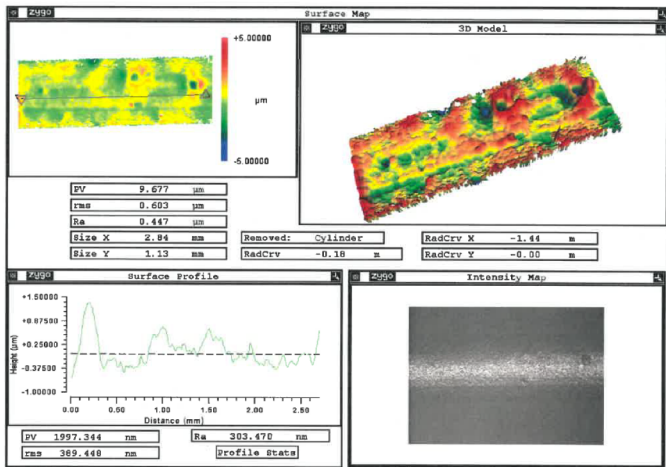

# Hydraulik Drive for shift gap axis

Hydraulik driven Cylinder as alternative to motor/spindel drive system

System: Bosch Rexroth 4WRPDH

valve with integrated regulation and interfaces or  $\mu$ -controller with valve

resolution valve: 0.001%

cycle time: <1ms



regulations:

- position
- force
- pressure
- position/pressure, position/force

connections:

EtherCAT, EtherNet, PROFINET, ...

<https://www.boschrexroth.com/de/de/produkte/produktgruppen/industriehydraulik/stetigventile/regel-wegeventile/direktgesteuert/integrierter-achsregler/iac-multi-ethernet/iac-multi-ethernet>

# Hydraulic Test setup

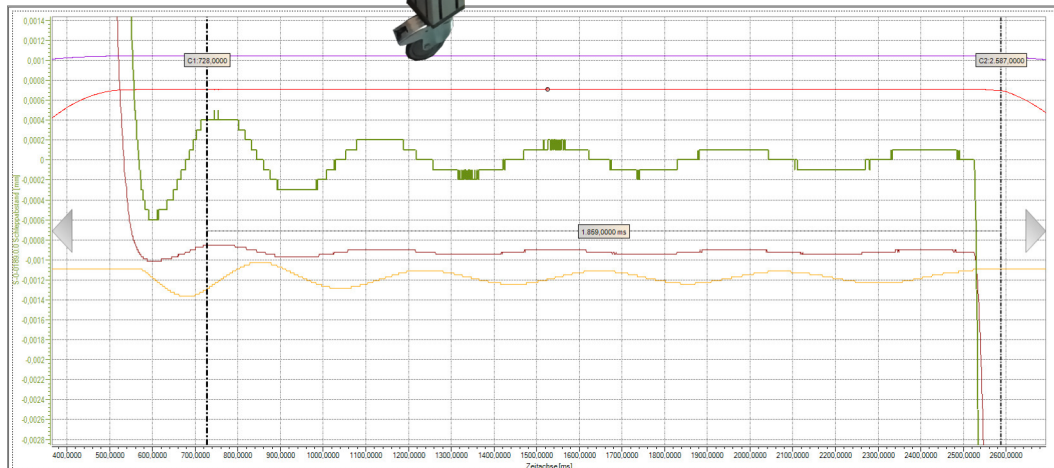
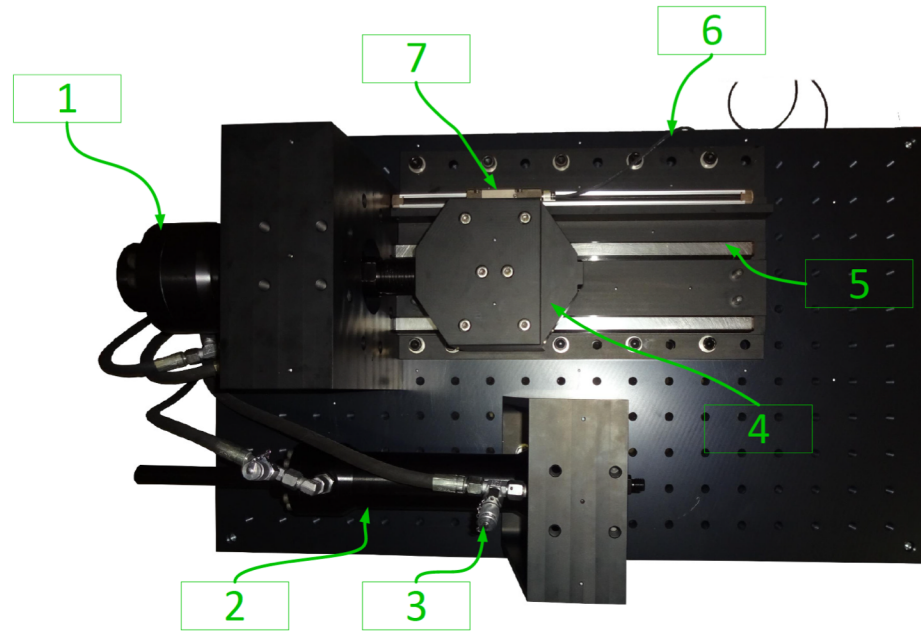
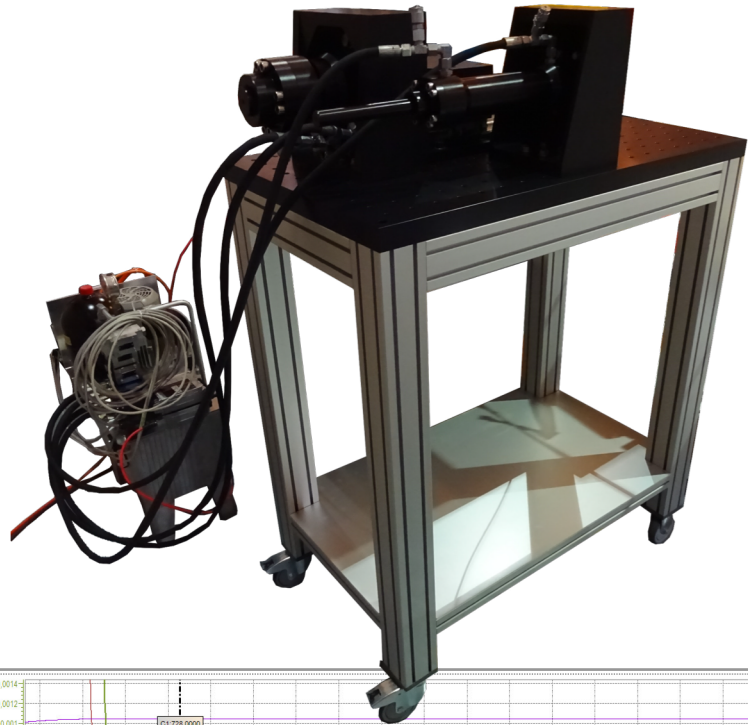

Elemente	Y-Achse Min	Y-Achse Max	Wert am Cursor	Einheit	default	Beschreibung
Messkonfiguration (Messung)					default	
Letzte Messung (Messung) [26.01.2017 14:4						
S-0-0434.0.0 Lagewert Regler	-65.850	17.783		10 mm		
S-0-0386.0.0 Aktiver Lagewert	1.000	11.845	9.9996	mm		
P-0-2831.0.1 Anteil Lageregel Yi	-0.003	0.001	0.0004	mm/s		
P-0-2831.0.3 Anteil Lageregel Integrator	-0.086	0.104	0.001	mm/s		
P-0-2831.0.5 Anteil Geschwindigkeitvori	-0.090	0.129	-0.01	mm/s		
DiagnosticTrace	-9.180	9.180	0	mm/s		

Signalname: S-0-0386.0.0 Aktiver Lagewert. X: 1.525.000 (ms) Y: 9.9999 (mm)

Magnet array needs to be unmount to install in vacuum vessel

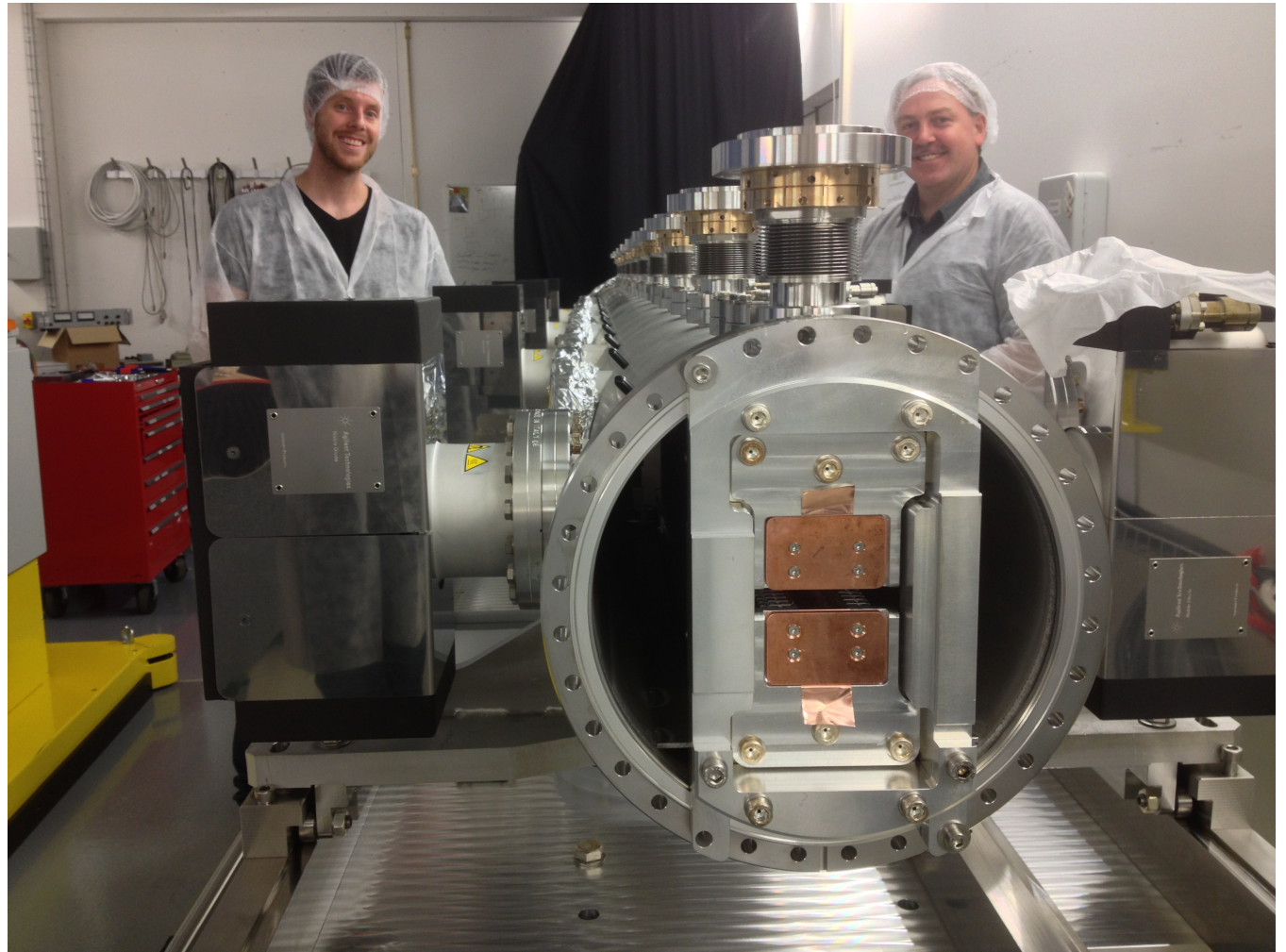

# Maximum performance of CPMU

PrFeB,  $B_r = 1.7T$

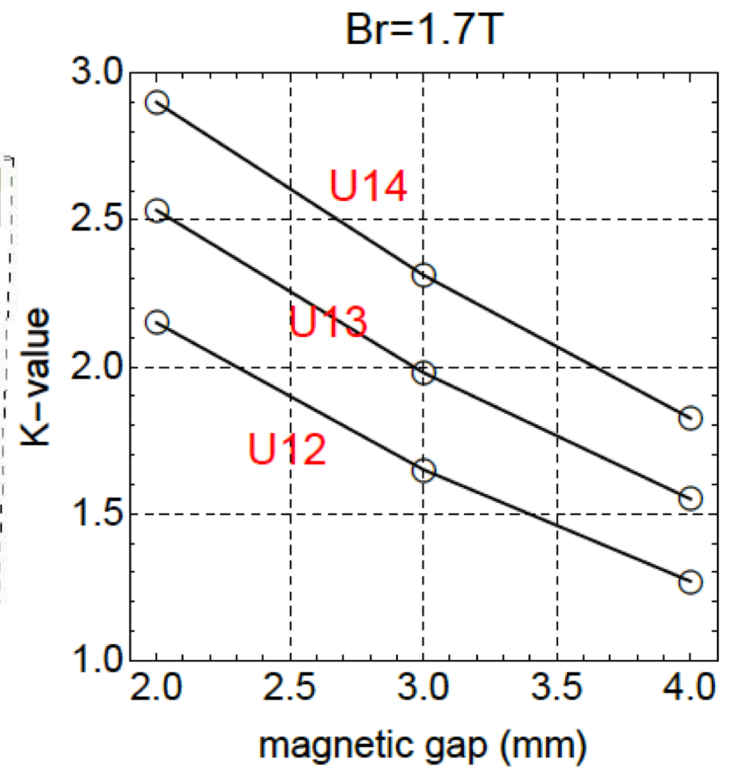
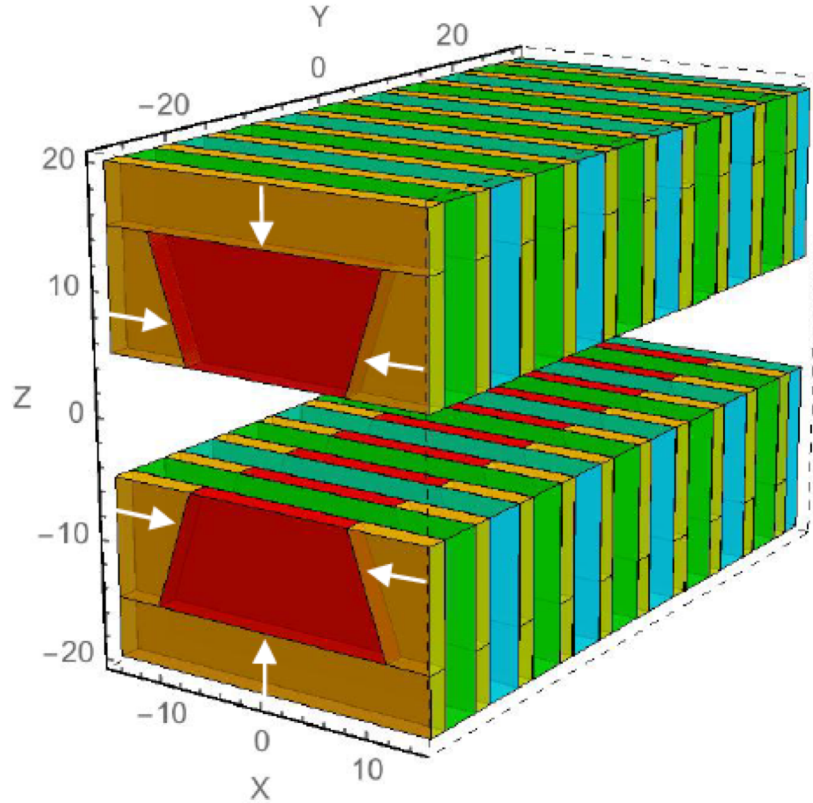

# K vs period for 100keV photon energy

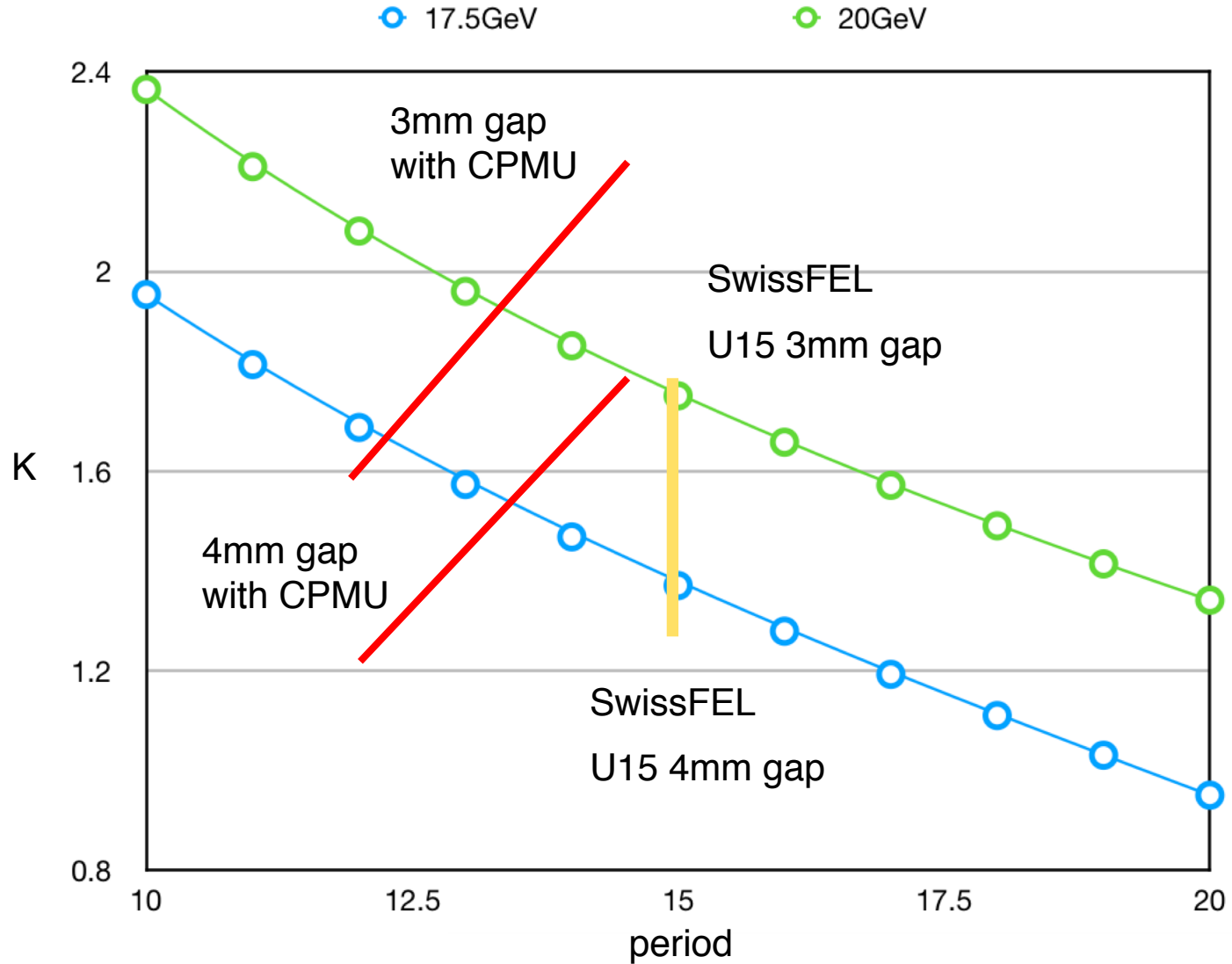

design without outer I-beam  
individual drives at every column  
wedge based, hydraulic, ....

**benefits:** gap dependent fine tuning  
compact, price

Industriestudie  
Helveting

